

**MokeWISE Program Final Memorandum:  
*Water Availability Analysis***

9 January 2015

---

**Table of Contents**

Introduction .....	1
Groundwater .....	2
Existing Groundwater Conditions.....	3
Summary of Potential Groundwater Supplies.....	11
Challenges with Maximizing Groundwater Use .....	11
Opportunities for Maximizing Groundwater Use.....	12
Agricultural Drainage Water.....	13
Potential Agricultural Drainage Supplies .....	13
Summary of Potential Agricultural Drainage Water Supplies .....	15
Challenges of Maximizing Agricultural Drainage Water Use .....	15
Opportunities for Maximizing Agricultural Drainage Water Use .....	15
Recycled Water .....	17
Wastewater Flows in the Watershed.....	17
Summary of Potential Recycled Water Supplies.....	38
Challenges with Maximizing Recycled Water Use .....	38
Opportunities for Maximizing Recycled Water Use.....	40
Stormwater .....	41
Potential Stormwater Capture.....	42
Existing and Potential Stormwater Programs .....	51
Summary of Potential Stormwater Supplies.....	54

Challenges with Maximizing Stormwater Use .....	54
Opportunities for Maximizing Stormwater Use.....	55
Conservation and Efficiency .....	57
Existing and Future Conservation Measures .....	57
Summary of Potential Conservation Savings .....	74
Challenges with Maximizing Conservation.....	75
Opportunities for Maximizing Conservation .....	75
Desalination.....	77
Regional Desalination Partnerships .....	81
Potential Supplies from Demineralization/Desalination .....	82
Summary of Potential Desalination/Demineralization Supply .....	83
Challenges with Maximizing Desalination/Demineralization Supply .....	83
Opportunities for Maximizing Desalination/Demineralization Supply .....	84
Mokelumne River.....	85
Background.....	85
Mokelumne Collaborative Group .....	86
Regulatory Setting .....	87
Overview of Results .....	91
Summary of Mokelumne River Supply .....	94
Challenges with Optimizing Mokelumne River Water Supply .....	94
Opportunities for Optimizing Mokelumne River Water Supply .....	95
Other Surface Water .....	96
Transfer Opportunities .....	96
Delta Supplies .....	106
Transfer Conveyance Alternatives.....	107
Summary of Potential Other Surface Water Supply .....	108

---

Challenges with Maximizing Other Surface Water Use ..... 108

Opportunities for Maximizing Other Surface Water Use ..... 109

Summary of Potentially Available Supply ..... 110

References..... 115

## List of Figures

Figure 1: Groundwater Basins within the MokeWISE Region .....	3
Figure 2: CCWD Monitoring Well Network .....	6
Figure 3: Spring 2014 Groundwater Levels in the Eastern San Joaquin Groundwater Subbasin .....	8
Figure 4: San Joaquin County and Delta Water Quality Coalition Area Zones .....	14
Figure 5: Wastewater Treatment Facilities in the Upper Watershed .....	18
Figure 6: Wastewater Treatment Facilities in the Lower Watershed .....	27
Figure 7: Wastewater Treatment Facilities in EBMUDs Service Area* .....	32
Figure 8: Average Rainfall in the Region .....	42
Figure 9: Impervious Areas in the Region .....	44
Figure 10: Average Stormwater Runoff in the Region .....	46
Figure 11: Approximate Dimensions of Required Storage .....	54
Figure 12: Chloride Concentrations of Wells in the Eastern San Joaquin Subbasin (1984 to 2004).....	78
Figure 13: Estimated 2000 and Projected 2030 Saline Front.....	80
Figure 14: Mokelumne River Flow Components* .....	93
Figure 15: Examples of Recent Water Transfers in Relation to the MAC and ESJ Regions.....	98

---

## List of Tables

Table 1: Average Change in Groundwater Level over Previous Year (in feet to mean sea level).....	10
Table 2: Wastewater Flows and Potential Recycled Water in the Upper Watershed .....	24
Table 3: Wastewater Flows and Potential Recycled Water in the Lower Watershed .....	30
Table 4: Wastewater Flows and Potential Recycled Water in the EBMUD Service Area .....	36
Table 5: Recycled Water Currently Used within the Upper and Lower Watersheds and EBMUD's Service Area .....	37
Table 6: Recycled Water Assumed Available for the MokeWISE Program.....	37
Table 7: Metrics for Upper and Lower Watershed Representative Cities.....	47
Table 8: Metrics for Calculating Residential Area in Upper and Lower Watersheds .....	48
Table 9: Average Monthly Rainfall in Upper and Lower Watersheds .....	49
Table 10: BMP Naming Changes in the CUWCC MOU and Water Savings Assumptions .....	59
Table 11: Commercial, Industrial, Institutional Water Savings Assumptions .....	60
Table 12: AWA Estimated Future Savings Potential Associated with Conservation BMPs .....	62
Table 13: CCWD Estimated Future Savings Potential Associated with Conservation BMPs .....	64
Table 14: Primary Water Supply Sources in the Lower Watershed .....	67
Table 15: City of Stockton Estimated Future Savings Potential Associated with Conservation BMPs .....	69
Table 16: City of Lodi Estimated Future Savings Potential Associated with Conservation BMPs .....	71
Table 17: Potential Agricultural Water Savings from Four BMPs .....	73
Table 18: Potential Additional Future Supply Available through Expanded Conservation Programs .....	74
Table 19: Diversion Assumptions for Current (2010) and Future (2040) Baselines .....	92
Table 20: Recent Water Transfers .....	99
Table 21: Percent of Time Surplus can be Expected to be Available if SWRCB Adopts Delta Flow Criteria as Flow Requirements.....	106
Table 22: Summary of Potentially Available Supply by Source .....	113

---

## List of Acronyms

20x2020	Water Conservation Act of 2009
ADWF	Average dry weather flow
AF	Acre-feet
AFY	Acre-feet per year
AGRIMET	Bureau of Reclamation Agricultural Weather Network
ARSA	Amador Regional Sanitation Authority
AWA	Amador Water Agency
AWMP	Agricultural Water Management Plan
B/C	Benefit-cost
BARDP	Bay Area Regional Desalination Project
BMPs	Best Management Practices
CARWSP	Camanche Area Regional Water Supply Plan
CCSD	Crockett Community Services District
CCCSD	Central Contra Costa Sanitary District
CCWD	Calaveras County Water District
CDCR	California Department of Corrections and Rehabilitation
CDEC	California Data Exchange Center
cfs	Cubic feet per second
CII	Commercial, industrial, and institutional
COCORAHS	Community Collaborative Rain, Hail and Snow Network
COOP	National Weather Service Cooperative Observer Program
COSMUD	City of Stockton Municipal Utilities Department
COWRP	Castle Parks Water Reclamation Plant
CPUD	Calaveras Public Utility District
CSD	Community Services District
CSD	Crockett Sanitary Department
CUWCC	California Urban Water Conservation Council

---

CVP	Central Valley Project
CWC	California Water Code
DFW	California Department of Fish and Wildlife
DMM	Demand Management Measure
DSRSD	Dublin San Ramon Services District
DWR	California Department of Water Resources
DWSP	Delta Water Supply Project
EBMUD	East Bay Municipal Utility District
EPA	United States Environmental Protection Agency
ESJ	Eastern San Joaquin
EWMP	Efficient Water Management Practices
FY	Fiscal year
GBA	North Eastern San Joaquin County Groundwater Basin Authority
GHMWC	Garden Highway Mutual Water Company
GIS	Geographic Information System
gpcd	Gallons per capita per day
gphd	Gallons per household per day
gpd	Gallons per day
GWMP	Groundwater Management Plan
HET	High Efficiency Toilet
ILRP	Irrigated Lands Regulatory Program
IRWMP	Integrated Regional Water Management Plan
JVID	Jackson Valley Irrigation District
LAVWMA	Livermore-Amador Valley Water Management Agency
LID	Low impact development
MAC	Mokelumne-Amador-Calaveras
MAF	Million acre-feet
MCG	Mokelumne Collaborative Group

---

MGD	Million gallons per day
MHSD	Mokelumne Hill Sanitary District
MokeWISE	Mokelumne Watershed Interregional Sustainability Evaluation
MOU	Memorandum of Understanding
MSPS	Mallard Slough Pump Station
MWELo	Model Water Efficient Landscape Ordinance
NLCD	National Land Cover Database
NMFS	National Marine Fisheries Services
NOAA HDSC	National Oceanic and Atmospheric Administration Hydrometeorological Design Studies Center
NPDES	National Pollutant Discharge Elimination System
NRWRP	North Richmond Water Reclamation Plant
NSJWCD	North San Joaquin Water Conservation District
OLSD	Oro Loma Sanitary District
PCWA	Placer County Water Agency
PMWC	Plumas Mutual Water Company
RARE	Richmond Advanced Recycled Expansion
RAWS	U.S. Forest Service and Bureau of Land Management Remote Automated Weather Stations
RO	Reverse osmosis
RSD	Rodeo Sanitary District
RWCF	Stockton Regional Wastewater Control Facility
RWQCB	Regional Water Quality Control Board
SASD	San Andreas Sanitary District
SAWPA	Santa Ana Watershed Project Authority
SAWS	Stockton Area Water Suppliers
SBx7-7	Water Conservation Bill of 2009
SCVWD	Santa Clara Valley Water District
SCWA	Sacramento County Water Agency

---



SCWWTP	Sutter Creek Wastewater Treatment Plant
SD	Sanitary District
SEWD	Stockton East Water District
SFCFCWCD	San Joaquin County Flood Control and Water Conservation District
SFPUC	San Francisco Public Utilities Commission
SMCL	Secondary Maximum Contaminant Level
SNOTEL	Natural Resources Conservation Service Snowpack Telemetry
SNOWCOURSE	Natural Resources Conservation Service Snow Course
SWRCB	State Water Resources Control Board
TAF	Thousand acre-feet
TBF	Tule Basin Farms
TDS	Total dissolved solids
TMDL	Total maximum daily load
UAW	Unaccounted-for water
ULFT	Ultra low flow toilets
UMRWA	Upper Mokelumne River Watershed Authority
USBR	United States Bureau of Reclamation
USFWS	United States Fish and Wildlife Services
USGS	United States Geological Services
UWMP	Urban Water Management Plant
VSPUD	Valley Springs Public Utility District
WCMP	Water Conservation Master Plan
WCSD	Wallace Community Services District
WCWD	West County Wastewater District
WDRs	Waste discharge requirements
WID	Woodbridge Irrigation District
WPCP	Water Pollution Control Plant
WRCC	Western Regional Climate Center

---

WRO	Water Rights Order
WSMP 2040	Water Supply Improvement Program 2040
WSS	WaterSense Specification
WSWPCF	White Slough Water Pollution Control Facility
WWMP	Wastewater Master Plan
WWTP	Wastewater treatment plant
YCWA	Yuba County Water Agency
Zone 7	Zone 7 Water Agency

## List of Definitions

**Unallocated water** – The quantity of water in the Mokelumne River that is not diverted pursuant to a riparian or appropriative water right and that is not required to be in the river pursuant to a prescribed pre-1914 regulatory requirement.

## List of Appendices

**Appendix A** presents the scope of work for a stormwater quantification project currently being implemented by EBMUD.

**Appendix B** presents further information on the conservation analysis, including the methodology and assumptions used to quantify the conservation BMPs for each agency.

**Appendix C** provides the MOCASIM for the MokeWISE Program Technical Memorandum, which further describes the MOCASIM model.

**Appendix D** shows the annual flow duration curves at four locations along the river. Flow duration curves indicate the percentage of time over the period of record that flow in the river would be expected to be equal to or exceed a certain amount of water, based on historical hydrologic conditions and projected diversion levels. Results indicate that total flow decreases downstream and that there is projected to be less flow in 2040 than in 2010 due to increased diversions.

**Appendix E** shows monthly unallocated flow alongside regulated flow and unimpaired flow for the full period of historical hydrology as simulated by the model. This appendix also shows flow distributions by month for five different hydrologic year types, at selected threshold flow levels. Results indicate that there is generally more unallocated flow in wetter years, and that there is a higher likelihood of unallocated flows occurring in the months from January to June compared with the months from July to December. Results also show less unallocated flows in 2040 than in 2010 due to increased diversions.

**Appendix F** compares average total natural flow at Mokelumne Hill and unallocated flow below Camanche in 2010 and 2040 by water year type. Results indicate that total natural flow is greater than unallocated flow at Mokelumne Hill and that unallocated flow in 2010 is greater than unallocated flow in 2040 due to increased diversions. This pattern holds for each of the five hydrologic year types.

**Appendix G** compares annual JSA required flows and annual modeled flows. Results indicate that the amount of water being released decreases from 2010 to 2040, but that in each case, more water is being released than is required by the JSA.

**Appendix H** presents a constructed daily flow regime downstream of Camanche Dam by year for all years between 1998 and 2010. For the three wet years during that period (1998, 2005, and 2006), daily allocated and unallocated flows are presented on a monthly basis. This information is shown to provide information regarding historical daily flow variability. It is not intended to establish estimated pulse flows or geomorphic and/or fishery impacts.

**Appendix I** shows the riparian diversions at Highway 99, Woodbridge Dam, and Interstate 5. Results indicate that diversions are greatest from May through July.

---

**Appendix J** shows unallocated water below Camanche for the 2010 and 2040 baselines. Results indicate that there is generally more unallocated water in the months from January to May, and that there is more unallocated water in the 2010 baseline than in the 2040 baseline.

**Appendix K** presents data for all relevant figures and tables from Appendices D through J in cubic feet per second (cfs) rather than in acre-feet. The values stated provide the average flow in cfs over the time period specified (year, month, etc.). One acre-foot per year is equivalent to 0.00138 cfs.

## Introduction

Basin-scale planning is currently underway within the Mokelumne River watershed under the auspices of the Upper Mokelumne River Watershed Authority (UMRWA) and the Eastern San Joaquin Groundwater Basin Authority (GBA), which represent the Mokelumne-Amador-Calaveras (MAC) and Eastern San Joaquin (ESJ) Integrated Regional Water Management Planning (IRWMP) Regions, respectively. Grant funding has been secured from the Proposition 84 Integrated Regional Water Management Program to develop the Mokelumne Watershed Interregional Sustainability Evaluation (MokeWISE) program, which seeks to improve water management in the Mokelumne River watershed.

The MokeWISE program has emerged following years of dialogue among a diverse set of stakeholders in the upper and lower Mokelumne River watersheds. MokeWISE, when concluded, is expected to yield a scientifically-based and broadly-supported water resources program that includes sustainable approaches to water resources management in the Mokelumne River watershed. Driving the development of the MokeWISE program is the Mokelumne Collaborative Group (MCG), a diverse and multi-faceted stakeholder group that includes water agencies, non-governmental organizations, private entities, resource agencies, and local, state, and federal government agencies.

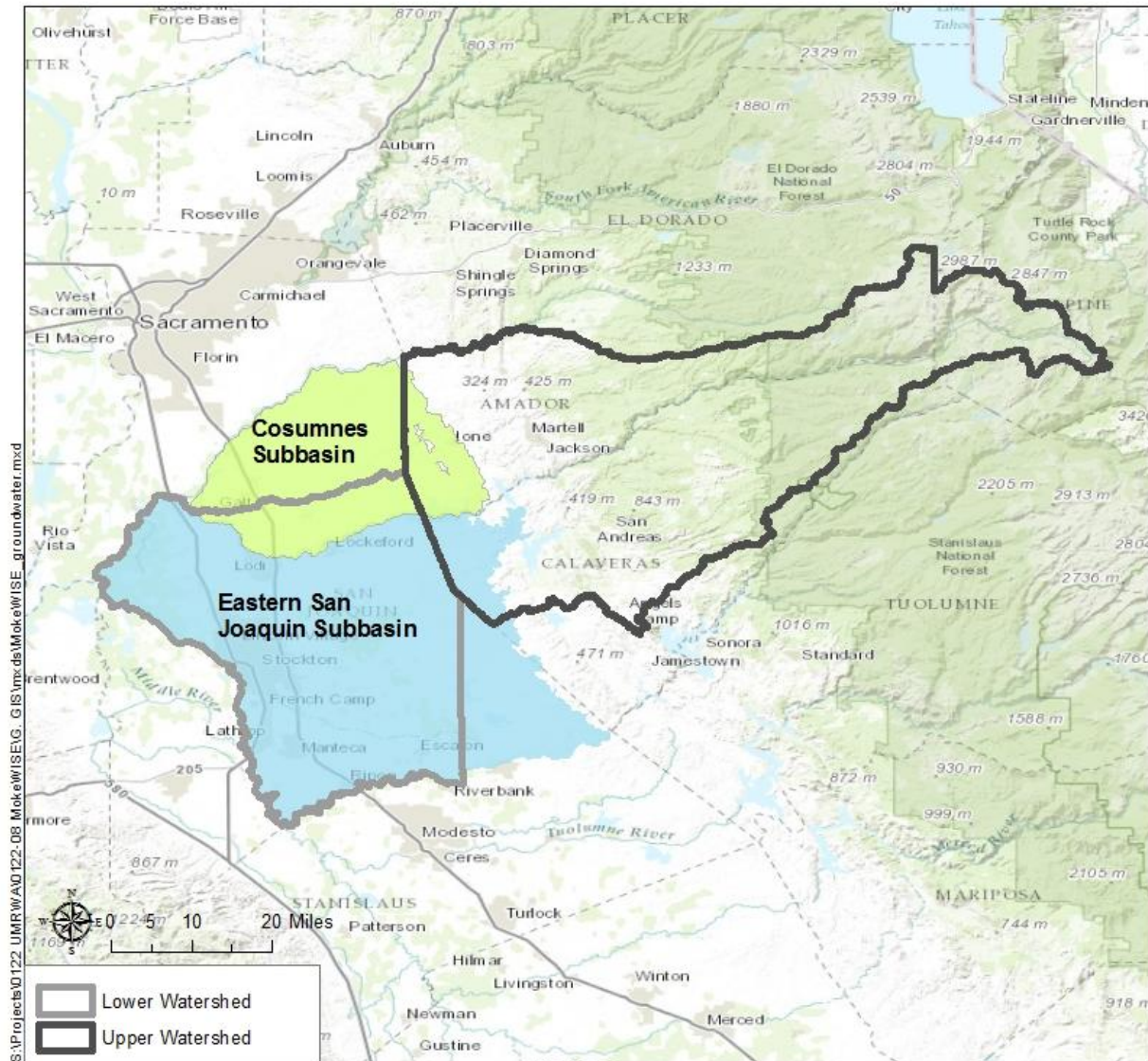
As part of the MokeWISE program, the MCG will evaluate potential water management actions that involve a variety of water sources. The purpose of this document is to assist in determining the quantity of water potentially available from each source, including groundwater, agricultural drainage, stormwater, recycled water, conservation, desalination, the Mokelumne River, and other surface water. These sources were investigated over a 30-year planning horizon, spanning from 2010 to 2040 and evaluated for their potential to provide supply to the upper and lower Mokelumne watersheds. In order to develop an effective water resource management projects that could affect both regions, there is a need to identify water supply.

The results of this water availability analysis will help develop the project concepts currently being considered in the MokeWISE process. The following sections summarize the results of the water availability analysis for each water supply source considered. The study area for this analysis covers the portions of the MAC and ESJ IRWMP regions in the Mokelumne River watershed, which are identified as the upper and lower watersheds, respectively. In some instances, water supplies from outside the watershed could be exchanged to free up additional supply within the watershed. These opportunities were also evaluated.

## **Groundwater**

Available groundwater supply in the Mokelumne Watershed and adjacent areas was assessed by collecting information about the current conditions of the groundwater basins underlying the project area (including both western Calaveras and Amador counties, and Eastern San Joaquin County groundwater basins). Data was collected from available groundwater management plans, urban water management plans (UWMPs), groundwater models, other groundwater resource evaluations, and relevant agencies. As shown in Figure 1, the MAC and ESJ regions overlie the Cosumnes and Eastern San Joaquin groundwater subbasins of the San Joaquin Valley Groundwater basin. This evaluation considered potential groundwater supplies from the groundwater subbasins underlying the upper and lower watersheds.

Figure 1: Groundwater Basins within the MokeWISE Region



## Existing Groundwater Conditions

### Groundwater in the Upper Watershed

The Cosumnes Subbasin is approximately 440 square miles in size, and is bounded on the north and west by the Cosumnes River, on the east by the bedrock of the Sierra Nevada, and on the south by the Mokelumne River. The groundwater storage capacity of Cosumnes Subbasin is estimated to be about 6,000,000 AF. Basin inflows are estimated to be about 269,500 acre-feet per year (AFY). Water leaves the Subbasin through subsurface flow (144,600 AFY), urban extraction (35,000 AFY), and agricultural extraction (94,200 AFY). Based on this water balance, the Subbasin is in overdraft by about 4,300 AFY (RMC 2013, 1-35). As such, no additional groundwater supply is available in this area. Due to the



variable quality and supply of the basin, groundwater storage potential is considered negligible (RMC 2012).

A portion of western Calaveras County, served by Calaveras County Water District (CCWD), overlies the Eastern San Joaquin Subbasin, which is part of the larger San Joaquin Valley Groundwater Basin. The Eastern San Joaquin Subbasin is estimated to cover approximately 70 square miles (7 percent) of Calaveras County. This groundwater subbasin extends from the western corner of the County west of the cities of Stockton and Lodi. Use of groundwater for irrigation, domestic, and municipal purposes has resulted in a continuous decline of available groundwater over the past 40 years. The California Department of Water Resources (DWR) designated the Eastern San Joaquin Subbasin as “critically overdrafted” in Bulletin 118-80. The Subbasin is currently being managed under an AB 3030 Groundwater Management Plan (GWMP), prepared by the GBA. The Camanche/Valley Springs area is managed under a separate GWMP, adopted by CCWD in 2001, for investigation of opportunities to improve management of groundwater resources in western Calaveras County (RMC 2013).

In 2012, the U.S. Geologic Survey (USGS), in cooperation with CCWD and DWR, completed test drilling and data collection for the Calaveras County portion of the Eastern San Joaquin Groundwater Subbasin to better understand aquifer conditions in the Camanche/Valley Springs area (USGS 2012). As described in the study, groundwater is typically suitable for agricultural, domestic, and public-supply uses. However, high concentrations of naturally occurring dissolved solids, iron, arsenic, and increasing nitrate concentrations could limit future use and/or increase costs for treatment. Some areas, especially near Burson, have experienced drying wells due to declining groundwater level.

Estimating the age of groundwater is a tool often used to determine the recharge capabilities of a groundwater basin. To estimate the age of groundwater within the Calaveras County portion of the Eastern San Joaquin Groundwater Subbasin, samples were collected from a number of monitoring wells for field parameters such as temperature, pH, and dissolved oxygen, as well as age-dating constituents including tritium and carbon-14 (see Figure 2). Tritium is a naturally occurring radioactive isotope of hydrogen that is anthropogenic, short-lived (half-life of 12.3 years) and can be used to identify relatively young (post-1952) groundwater. Tritium detected in groundwater can often be attributed to thermonuclear weapons testing from 1952 to 1962. Tritium was detected in only one of six wells, indicating that groundwater recharge in the study area is small or requires a long time to infiltrate through the unsaturated zone to the water table.

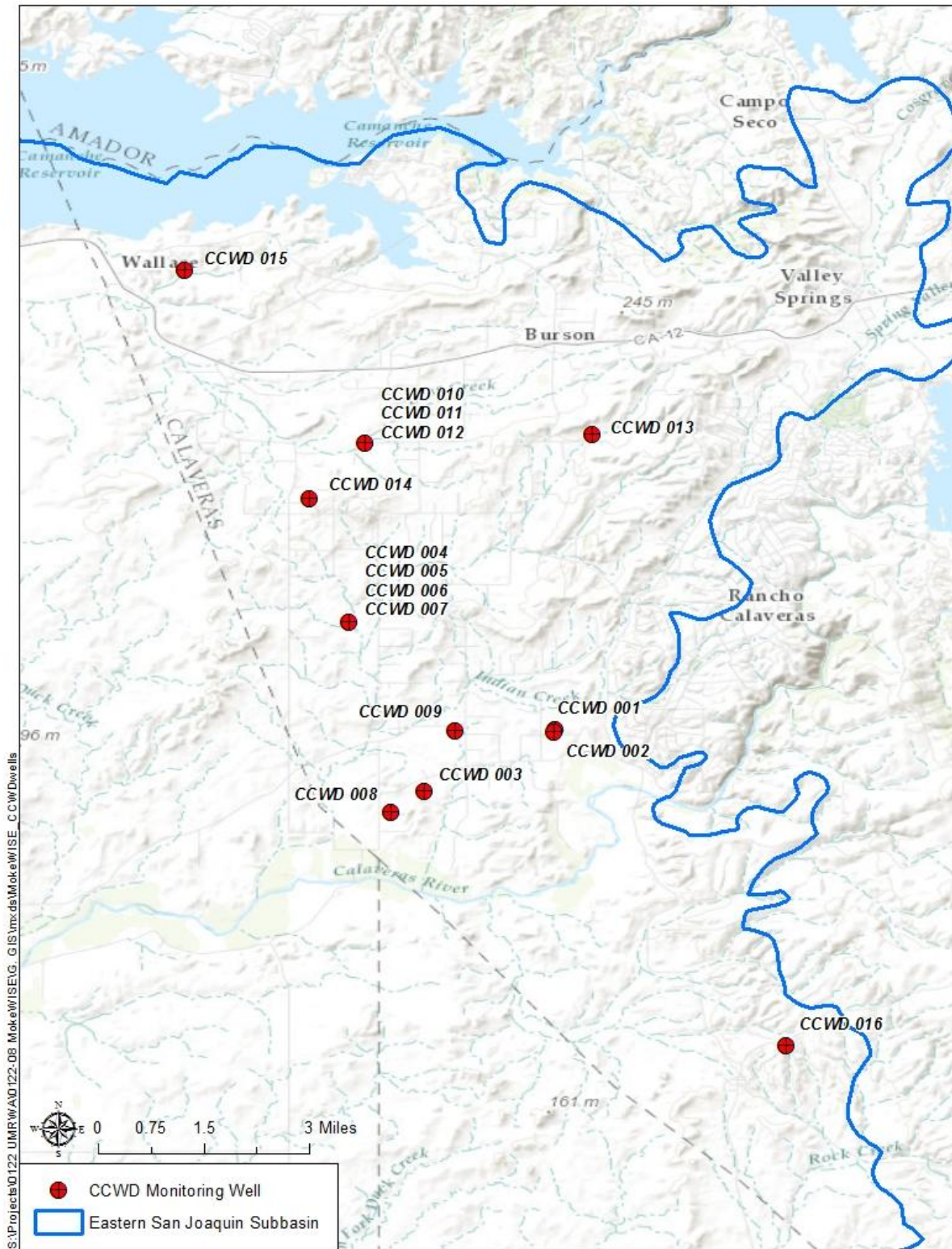
Carbon-14 is a naturally occurring radioactive isotope of carbon that is long-lived with a half-life of 5,730 years. It allows for identification of groundwater up to 30,000 years old. Results from the six monitoring wells indicate the water ranges in age from 2,200 to 13,400 years old, becoming progressively older with depth. This indicates that: (1) extensive chemical reactions alter carbon-14 activities, (2) groundwater recharge is limited (which is consistent with the absence of tritium), or (3) groundwater requires a long time to infiltrate to the groundwater table (USGS 2012, 10-11). The well with the youngest groundwater was

also the well with detected levels of tritium, which suggests more recent recharge. In order to confirm and augment the USGS study, CCWD prepared and implemented a groundwater sampling plan (Dunn Environmental 2012). The sampling effort had the following objectives:

- Collect additional water quality data to substantiate past findings.
- Collect additional age dating data to confirm and augment tritium and carbon-14 results from the USGS study.
- Assess potential groundwater recharge throughout the County portion of the subbasin.

While there may be localized areas suitable for groundwater recharge in the Calaveras County portion of the Eastern San Joaquin Groundwater Subbasin, based on the USGS study, natural recharge opportunities are limited and additional groundwater storage may not be available. While the feasibility and effect of using injection wells for recharge has not been extensively studied in the ESJ basin, there may be potential for their use.

Figure 2: CCWD Monitoring Well Network



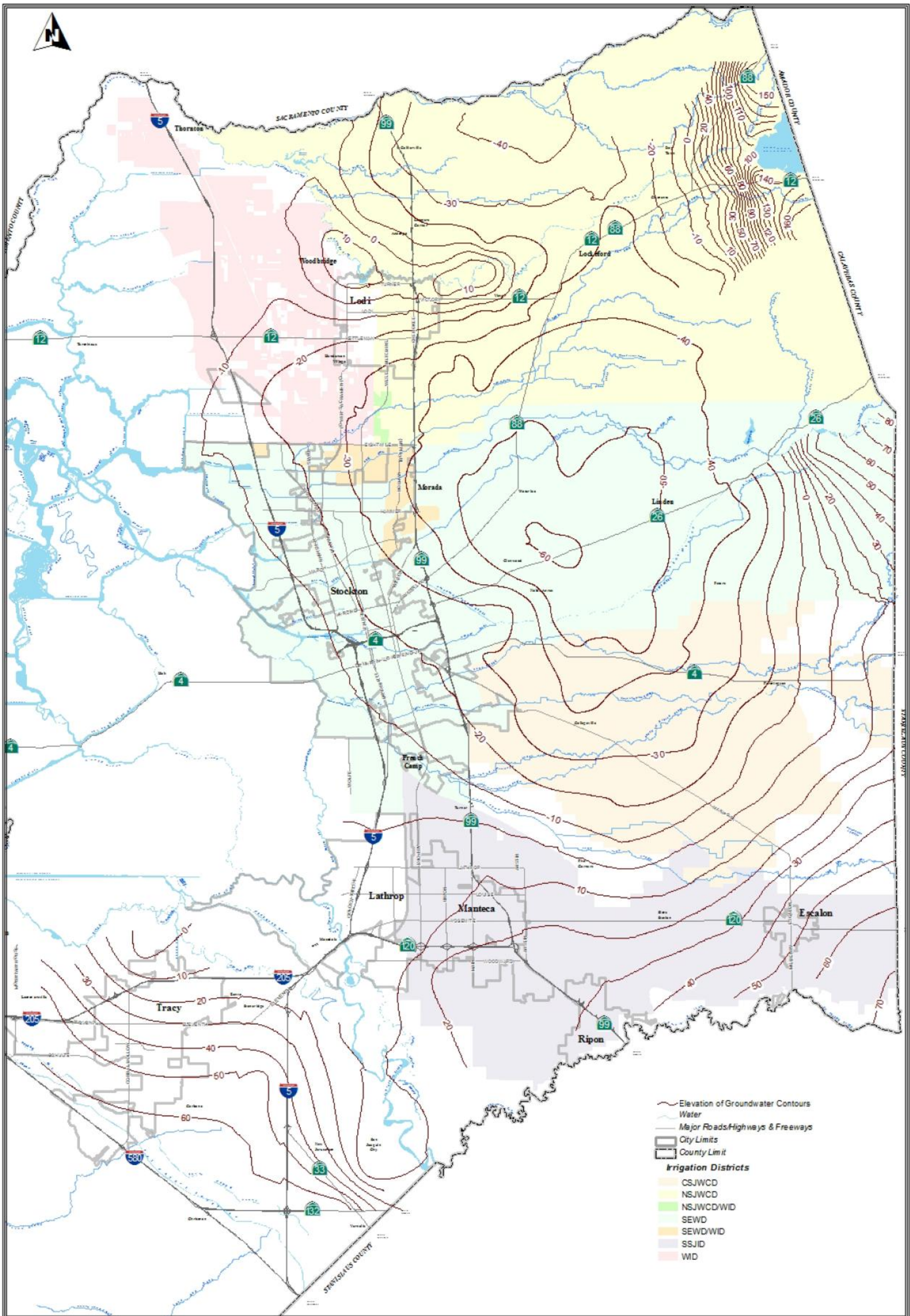
## Groundwater in the Lower Watershed

Groundwater measurements taken in Eastern San Joaquin County dating back to the 1960s show a fairly continuous decline in groundwater levels, with elevations dropping as much as 100 feet in some areas. Based on land use and population, total agricultural and municipal groundwater pumping in Eastern San Joaquin County is estimated to have averaged 870,000 AFY since the 1970s, which has resulted in the groundwater subbasin being overdrafted and reducing the volume of water stored in the basin by as much as 2 million acre-feet (AF) (DWR 2006b, 3). Over the last century, irrigated agriculture in the Central Valley has grown from less than 1 million acres to an estimated 7 to 8 million acres. Water demand in San Joaquin County is approximately 1.6 million AFY. The County currently relies on groundwater for 60 percent of its supplies, with surface water meeting the remaining 40 percent of demands. The Eastern San Joaquin groundwater subbasin is currently overdrafted at a rate of 150,000 to 160,000 AFY (GBA 2004, 69). Between 140,000 and 160,000 AFY of water is anticipated to be needed by 2030 to reverse overdraft conditions and stabilize the groundwater basin at target levels, assuming an estimated 2030 level of development as specified in either adopted or draft general planning documents (GBA 2007, ES-27).

As shown in Figure 3, as of spring 2014, groundwater was significantly overdrafted throughout the subbasin, with the greatest depression east of the City of Stockton with elevations as low as 60 feet below ground surface. Long-term groundwater overdraft has dramatic effects on groundwater levels and water quality. Portions of the subbasin have exhibited groundwater levels declining by as much as 2 feet per year, up to 90 feet below sea level (GBA 2007, 1-2). Groundwater level declines have resulted in steep gradients from the west, causing intrusion of highly saline groundwater. Degradation of water quality due to saline migration threatens the long-term sustainability of the groundwater basin in the long term. In the near term, users face failing groundwater wells, reduced pumping rates, and poor water quality. Salt intrusion in the groundwater basin has rendered supplies unusable for urban drinking water needs and crop irrigation in some locations. Studies and monitoring to determine the potential sources and extent of the saline front are limited. Results of a USGS Joint Salinity Study (USGS 2006) indicated several possible sources of saline water including surface water infiltration, dissolution of salts near the Delta margin, contributions from underlying deposits, and possible irrigation return flow. Saline intrusion is discussed in more detail in the Desalination section. Even with conservation and recycled water programs in place, reversing groundwater overdraft will require a substantial amount of supplemental water (GBA 2007).

There are seven incorporated cities within San Joaquin County: Escalon, Lathrop, Lodi, Manteca, Ripon, Stockton, and Tracy. Escalon and Ripon are entirely dependent on groundwater for all potable and non-potable demands. However, these cities are taking steps to diversify supplies with surface water.

Figure 3: Spring 2014 Groundwater Levels in the Eastern San Joaquin Groundwater Subbasin



Source: SJCFWCD 2014.

Recent studies suggest that while groundwater levels in some parts of the subbasin may have begun to recover, most areas continue to reflect declining conditions. Hydrographs from the spring 2014 Groundwater Report published by the San Joaquin County Flood Control and Water Conservation District (SJCFCWCD) indicate that groundwater surface elevations in many of the wells throughout San Joaquin County were in decline from the beginning of the period of record (~1958) through today. Fluctuations in levels have been observed throughout the years, with some wells exhibiting increasing levels in recent years or somewhat constant levels. However, most wells have exhibited a constant decline (SJCFCWCD 2014). The 2014 *Groundwater Resources Management Report* (Wagner & Bosignore 2014, 22) recommends identification and assessment of risks to the groundwater basin to determine the resiliency of existing wells and the potential to meet future groundwater demands. Risks include, but are not limited to:

- Reduction of surface water supplies through regulatory actions;
- Increased diversions upstream;
- Reduced conservation storage in area reservoirs;
- Prolonged and/or intense drought periods; and
- Increased future demands.

The report recommends development of a Basin Conceptual Model and ultimately a numerical groundwater model, which would facilitate evaluation of the future risk of overdraft conditions and help aid in the development of water banking criteria, operational limitations for extraction, and the understanding of artificial and natural recharge (Wagner & Bosignore 2014).

As noted above, review of the spring 2014 Groundwater Report published by the SJCFCWD indicates that while the majority of the areas in the basin are declining, some areas of the basin are beginning to stabilize (SJCFCWD 2014). Table 1 provides the average groundwater level change over the previous year by jurisdictional monitoring area. That is, the change noted in Spring 2014 indicates the change in groundwater level from Spring 2013 to Spring 2014. Note that there are a number of wells within each monitoring area and the below numbers represent the average.

**Table 1: Average Change in Groundwater Level over Previous Year (in feet to mean sea level)**

<b>Year</b>	<b>Central San Joaquin Water Conservation District</b>	<b>North San Joaquin Water Conservation District</b>	<b>Oakdale Irrigation District</b>	<b>Stockton East Water District</b>	<b>South San Joaquin Irrigation District</b>	<b>Woodbridge Irrigation District</b>	<b>Southwest County Areas</b>
<b>Spring 2009</b>	-1.5	-3.0	-2.6	-3.1	-2.7	-1.8	-1.0
<b>Spring 2010</b>	-1.2	-0.9	1.1	-1.2	-0.5	0.2	0.2
<b>Spring 2011</b>	1.8	0.1	0.2	1.9	1.0	1.8	1.3
<b>Spring 2012</b>	0.52	0.4	-0.15	-0.1	1.0	-0.3	0.2
<b>Spring 2013</b>	-4.37	-0.47	-3.53	-1.34	-2.11	-0.86	-0.73
<b>Spring 2014</b>	-1.76	-2.62	-2.20	-2.59	-1.84	-2.38	-0.33

Based on this analysis, it is assumed that no additional groundwater is available from the Eastern San Joaquin Groundwater Basin. However, recent studies including the Eastern San Joaquin Groundwater Basin GWMP (GBA 2004) have shown that the groundwater overdraft may have created an estimated 1 to 2 million AF of groundwater basin storage which could be used in a groundwater banking or conjunctive use development. Groundwater banking and conjunctive use are recognized as key water management options for water agencies to balance water needs. There is interest statewide in implementing a groundwater bank in Eastern San Joaquin County. Interested parties include DWR, United States Bureau of Reclamation (USBR), CALFED Storage, Metropolitan Water District of Southern California, State Water Contractors, East Bay Municipal Utility District (EBMUD), AWA, and CCWD.

Recent legislature has the potential to greatly affect groundwater management within California. Senate Bill (SB) 1739 would require a groundwater sustainability agency to submit a groundwater sustainability plan and would grant that agency the ability to impose fees. SB 1168 would require that each groundwater basin be characterized with a priority and include consideration of adverse impacts on local habitat and local streamflows. SB 1319 would authorize the State Board to designate certain high- and medium-priority basins as probationary basins. Each of these bills has the potential to alter the groundwater landscape within the MokeWISE region. However, because each of these bills was recently signed by the Governor, this analysis cannot include a thorough analysis of their impact.

### Summary of Potential Groundwater Supplies

Aside from the groundwater currently used and planned for use, groundwater is not a viable additional water supply in the upper watershed for the MokeWISE program because of limited yield. Based on water age findings, large-scale natural groundwater recharge is unlikely to be viable in the Calaveras County portion of Eastern San Joaquin subbasin. Total agricultural and municipal groundwater pumping in Eastern San Joaquin County is estimated to have averaged 870,000 AFY since the 1970s, which has contributed to overdraft conditions. Continuing current rates of groundwater extraction will further impact groundwater levels, and saline groundwater will continue to migrate east into the basin (GBA 2004, 77). This will continue to impact the availability of groundwater in the future. Conjunctive management strategies (i.e. management of groundwater and surface water resources) and groundwater recharge opportunities may help to mitigate groundwater overdraft conditions.

### Challenges with Maximizing Groundwater Use

Challenges associated with maximizing the use of groundwater as a supply in the MokeWISE program are listed below. These challenges should be considered in conjunction with any groundwater projects resulting from the MokeWISE program.

- **Availability.** In the Cosumnes Subbasin within the upper watershed, private wells pump groundwater for use; however, because groundwater availability is limited in



the upper watershed, the potential for expanded use of groundwater in the upper watershed is also limited. Additionally, widely, distributed, small capacity wells in fractured rock offer very limited opportunities for coordinated management.

- **Groundwater basin conditions.** Groundwater from the Eastern San Joaquin Groundwater Subbasin is widely used in the lower watershed for agriculture and domestic supplies, but the basin, while recovering, has historically seen declining levels. Balancing the demands of users with the groundwater available is a challenging aspect of using groundwater as a supply.

### **Opportunities for Maximizing Groundwater Use**

The following are potential opportunities for maximizing groundwater use. These examples can be considered when discussing potential MokeWISE projects and programs.

- **Direct/in-lieu banking.** Low groundwater levels provide opportunities for potential banking and conjunctive use projects and programs. Water sources could include unused American, Sacramento, and/or Mokelumne River, stormwater, and/or recycled water supplies.
- **Direct injection.** Water from a variety of sources, including the Mokelumne, stormwater, recycled water, and agricultural drainage water, could be used to stabilize groundwater basin levels through direct injection.

## **Agricultural Drainage Water**

Agricultural drainage water is excess irrigation water collected from agricultural field drainage systems. Traditionally, agricultural drainage water may have been a significant supply source, but due to more efficient agricultural irrigation practices and water quality concerns, it is no longer considered a viable source. In the future, there may be a need to flush agricultural soils to reduce salt build-up, potentially creating agricultural drainage water. However, these practices are not currently being implemented and the quantity and quality of any potentially available water resulting from this use is unknown.

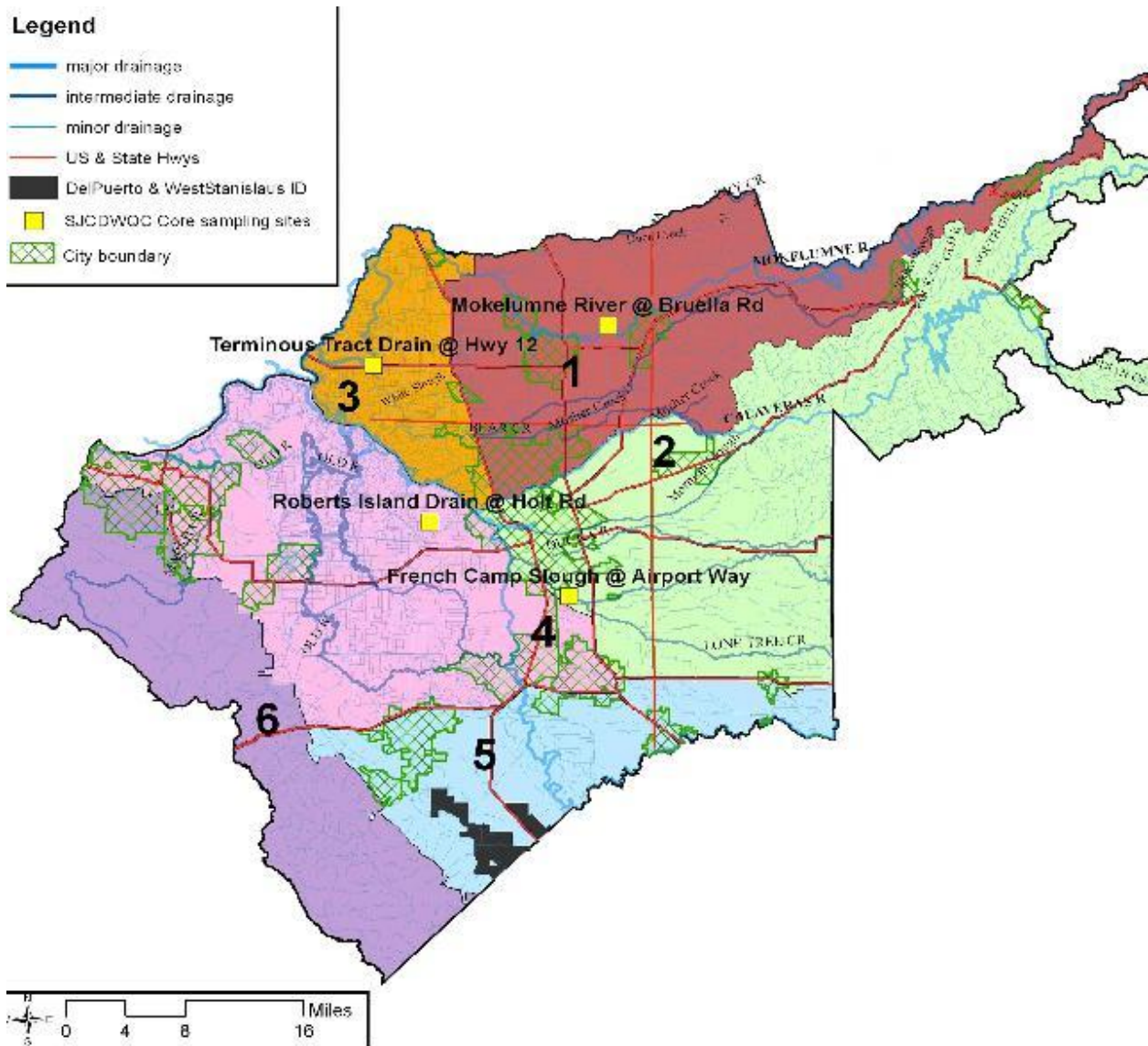
Agricultural drainage supplies were quantified by collecting data from the State Water Resources Control Board (SWRCB) and Regional Water Quality Control Board (RWQCB) to estimate the amount of agricultural drainage water and determine whether it is a viable potential source of supply for the future.

## **Potential Agricultural Drainage Supplies**

Water discharge from agricultural irrigation and operations includes runoff, flows from tile drains, and stormwater runoff. Because these discharges can affect water quality by transporting pollutants such as pesticides, sediment, nutrients, and salts to surface water, the Irrigation Lands Regulatory Program (ILRP) regulates discharges from irrigated agricultural land. Waste discharge requirements (WDRs) or conventional waivers of WDRs (Orders) to growers require water quality monitoring of receiving waters and corrective actions when impairments are found. There are approximately 40,000 growers enrolled in the ILRP encompassing 6 million acres in California (SWRCB 2014a).

The San Joaquin County & Delta Water Quality Coalition was established in response to the ILRP to help meet agricultural water quality requirements in San Joaquin County, Calaveras County, the Delta portions of Alameda and Contra Costa Counties, a portion of Stanislaus County north of the Stanislaus River, and a small portion of Amador County that drains into the Mokelumne River. The ILRP requires growers that irrigate their land and have runoff from that irrigation or rainfall to belong to a coalition or apply for an individual discharge permit from the RWQCB. The Mokelumne River watershed is primarily within Zones 1, 2, 3, and portions of 4 and 5 of the Coalition (see Figure 4). Zones within the Coalition are established for areas with similar characteristics. Water quality monitoring occurs within the zones to identify areas that may be exceeding water quality standards. In March 2014, the Central Valley RWQCB approved a new General Order for the San Joaquin County and Delta Watershed area (San Joaquin County and Delta Water Quality Coalition 2014).

Figure 4: San Joaquin County and Delta Water Quality Coalition Area Zones



Source: San Joaquin County and Delta Water Quality Coalition 2014

Within the Coalition area, the lower reaches of the San Joaquin River drain the eastern and western areas of the Central Valley. Drainage water is exported to the San Francisco Bay through the Delta or conveyed south via the State Water Project and Delta Mendota Canal (San Joaquin County and Delta Water Quality Coalition 2008).

In 2007, the Central Valley RWQCB prepared the *Revised Draft of the 2007 Review of Monitoring Data for the Irrigated Lands Conditional Waiver Program* to assess data collected for the Irrigated Lands Program since its inception in 2003. For the purposes of the report, the Central Valley Region was divided into four zones. Zone 2 includes parts of the San

Joaquin, Contra Costa, Alameda and Calaveras Counties, and the Delta. Participants in Zone 2 include the San Joaquin and Delta Water Quality Coalition, Oakdale Irrigation District, and South San Joaquin Irrigation District. Many growers in Zone 2 utilize an intricate system of conveyance canals for the purpose of returning tail water back to upstream farms, allowing growers to transport and reuse runoff or tail water in upgradient areas (CVRWQCB 2007). Reports and data available from the SWRCB, RWQCB, and the San Joaquin County and Delta Water Quality Coalition provide water quality information, but do not quantify agricultural drainage water.

### **Summary of Potential Agricultural Drainage Water Supplies**

While quantities of agricultural drainage are unknown, it is assumed that they are decreasing due to investments in agricultural irrigation efficiency practices and technologies. As such, it is not recommended that this source be relied upon as a significant source of water. Some local, small-scale applications may be viable for agricultural drainage, but it is not expected to contribute to a viable regional water supply. Additionally, it is important to consider the potential impacts associated with the capture of agricultural drainage, including reductions in water available for downstream environmental, agricultural, and urban uses. Furthermore, use of agricultural drainage water may reduce groundwater recharge. For these reasons, agricultural drainage water is not considered a viable source for the MokeWISE program.

### **Challenges of Maximizing Agricultural Drainage Water Use**

While agricultural drainage water is assumed to be decreasing, its use has the potential to pose challenges for downstream water users. In many cases, downstream users divert agricultural drainage water that was discharged by upstream users. As agricultural efficiencies are realized, this source is naturally decreasing, while potentially increasing the concentrations of contaminants. Capture and reuse of agricultural drainage water would further decrease this source for downstream users, thereby potentially decreasing the supplies available for downstream water users and groundwater users. Additionally, treatment of agricultural drainage water for use would need to be identified and implemented. These challenges should be addressed when considering projects which use agricultural drainage water as a supply.

### **Opportunities for Maximizing Agricultural Drainage Water Use**

The following are potential opportunities for maximizing agricultural drainage water use. These examples can be considered when discussing potential MokeWISE projects and programs.

- **Soil flushing.** Soil flushing is an agricultural practice in which water is applied to decrease the concentration of salts and other constituents that can build up in the soil over time. While some soil flushing occurs now within San Joaquin County, this practice is limited, and the amount of water that could potentially be captured and

used is negligible. Additionally, any water that does result from flushing both recharges the groundwater and is potentially used by downstream users. However, water may be available in the future if soil flushing becomes a more common practice implemented at a larger scale.

## Recycled Water

Potentially available recycled water was determined by quantifying treated wastewater within the watershed and the volume of recycled water that is currently used or planned for future use. The remaining amount, after considering constraints, may be available for reuse.

## Wastewater Flows in the Watershed

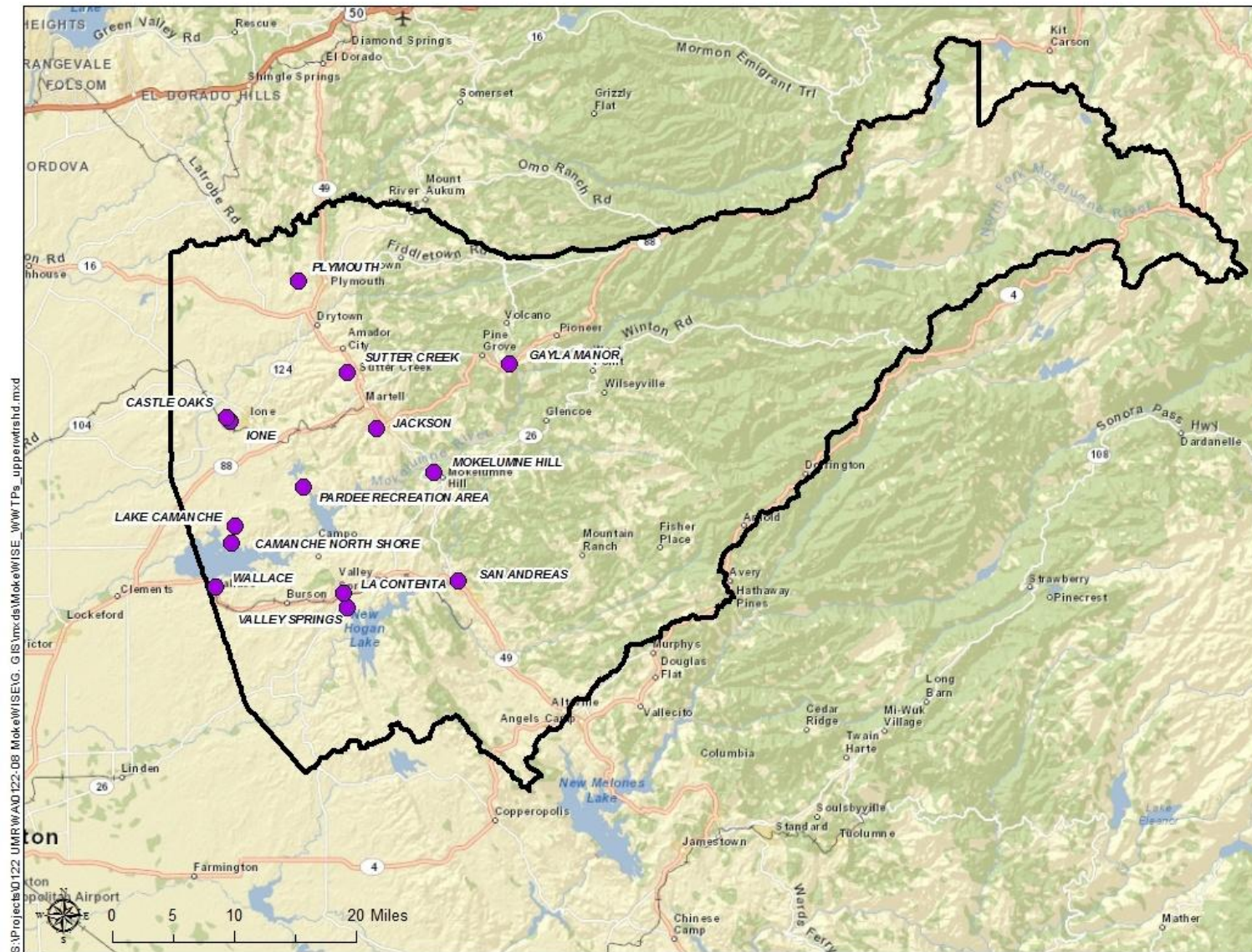
Unless noted, all annual flows were converted from Average Dry Weather Flow (ADWF) reported in million gallons per day (MGD) to acre-feet per year (AFY). This results in a conservative estimate of available supply because it does not include wet weather flows, which are difficult to store for use during dry times. All cited flows are from current, published documents and are based on assumed rates of population growth and buildout population assumptions. It should be noted that there is significant uncertainty associated with projecting future population growth, and the growth rates projected in some of these documents are greater than the rates that have been experienced in the past. If population grows at a slower rate than projected, future wastewater flows will be less than what is cited in this document, thereby decreasing the amount of recycled water that could potentially be available. Conversely, if population growth increases at a rate faster than that assumed by these planning documents, wastewater flows would be expected to be greater than cited, and a greater amount of recycled water may potentially be available in future years.

## Upper Watershed

The following agencies own and operate the major wastewater collection and treatment facilities within the upper watershed: AWA, Amador Regional Sanitation Authority (ARSA), City of Sutter Creek, City of Ione, City of Jackson, City of Plymouth, CCWD, EBMUD, Mokelumne Hill Sanitary District (MHSD), San Andreas Sanitation District (SASD), Valley Springs Public Utility District (VSPUD), and Wallace Community Services District (WCSD). Some of these agencies operate more than one facility and some share conveyance and discharge facilities.

The majority of the water treatment facilities in this region serve small, unincorporated areas with wastewater ADWF of less than 600 AFY. Only four wastewater treatment plants (WWTPs), including La Contenta WWTP, Castle Oaks Water Reclamation Plant (COWRP), City of Ione Secondary Treatment Plant, and City of Jackson WWTP, are projected to generate more than 1 MGD (1,120 AFY) at buildout, with a combined flow of approximately 9,000 AFY at buildout. Several agencies currently use recycled water to meet part of their water demands, as discussed in a subsequent section. Each of the agencies and the wastewater treatment facilities they operate are described in detail below. All flows associated with the upper watershed are captured in Table 2. Figure 5: Wastewater Treatment Facilities in the Upper Watershed identifies the location of each of the treatment plants discussed in the following sections.

Figure 5: Wastewater Treatment Facilities in the Upper Watershed



### *Amador Water Agency*

AWA owns and operates ten wastewater systems within the MAC region. The Lake Camanche WWTP and the Gayla Manor WWTP are the only two treatment plants and provide secondary treatment with disinfection and spray irrigation for disposal. The other eight systems are community leach fields that serve the communities of Eagles Nest, Fairway Pines, Jackson Pines, Mace Meadows, Pine Grove, Surrey Junction, Tiger Creek Estates, Viewpoint, and Wildwood Estates. These leach field systems dispose of primary treated wastewater through subsurface drains and produce such limited quantities of wastewater or are so geographically distant from potential users that reuse would be inefficient and cost-prohibitive (AWA 2011). In total, AWA collects and treats approximately 110 AFY of wastewater in the MAC region, but only the flows from the Lake Camanche WWTP and the Gayla Manor WWTP are feasible for recycled water use because these are the only two facilities which produce significant amounts of secondary treated water. The combined existing flow from these two treatment facilities is just over 60 AFY, with flows reaching a combined 132 AFY in the future.

### *Amador Regional Sanitation Authority: City of Sutter Creek/City of Amador City/Martell*

The City of Sutter Creek owns and operates the Sutter Creek Wastewater Treatment Plant (SCWWTP), which serves the cities of Sutter Creek, Amador City, and the community of Martell (Aegis 2013, 4-9). SCWWTP expansion capacity is limited to approximately 1 MGD due to its location; however, an adjacent site has been identified for a future WWTP. Secondary effluent produced by the SCWWTP is chlorinated and discharged to the Amador Regional Sanitation Authority (ARSA) system for storage and reuse or disposal.

The ARSA Regional Outfall originates at the City of Sutter Creek WWTP, and allows effluent to be routed either to the City of Ione's tertiary level COWRP, or to the City of Ione's Secondary Treatment Plant (ponds) south of the Sutter Creek streambed. Along the ARSA pipeline, a portion of the treated effluent is used for pasture grass application at Bowers Ranch and Hoskins Ranch. The City of Ione accepts from ARSA and the California Department of Corrections and Rehabilitation (CDCR) a combined total of 650 AFY of secondary-treated wastewater for disposal (Aegis 2013, 4-3).

Buildout flows are planned to be 0.913 MGD or 1,023 AFY based on the ARSA Wastewater Master Plan (WWMP) (HydroScience 2012, 5). Other studies provide alternate projections of future buildout flows. Future recycled water use is anticipated to be roughly 1,000 AFY.

### *Calaveras County Water District*

CCWD operates five larger wastewater treatment facilities (>0.1 MGD) and nine smaller systems serving approximately 5,000 wastewater connections in total. The effluent produced by the treatment facilities is disposed of in three principal ways: community leach field systems, spray disposal, and irrigation. Three of the plants contain facilities to recycle wastewater for golf course irrigation (CCWD 2011, 5-1).



Wastewater treatment facilities treating less than 0.1 MGD are located in the following communities: Douglas Flat/Vallecito, West Point, Wilseyville Camp, Country Houses, Indian Rock, Millwoods, Sequoia Woods, and Southworth. The Country Houses, Sequoia Woods and Southworth communities are near buildout, and additional connections are not anticipated. Flows at the other facilities are gradually approaching capacity, and the agencies will need to begin making plans for treatment capacity expansions (Calaveras LAFCO 2012, 75). While the Arnold wastewater treatment facility treats 0.1 MGD or 118 AFY of wastewater, it currently only treats to primary standards and is therefore not discussed further below. Copper Cove, Forest Meadows, and Douglas Flat/Vallecito treatment plants, while owned by CCWD, are not hydrologically connected to the Mokelumne River. In other words, any recycled water use connected to these facilities would not offset Mokelumne River water. As such, these wastewater treatment facilities are also not discussed below

Tertiary-treated effluent from the La Contenta wastewater treatment facility is stored and used for golf course irrigation. The La Contenta Golf Course uses the plant effluent as its primary irrigation supply source, and uses raw water from New Hogan Reservoir to meet its supplemental water supply needs. CCWD intends to incorporate additional wastewater recycling programs in other areas, such as parks, landscape, and highway medians once effluent volumes exceed current irrigation demands. Without these alternatives, CCWD would dispose of additional effluent through dedicated land application (CCWD 2011, 5-3). Current wastewater flows are 225 AFY and are expected to increase to 1,636 AFY by 2040.

### *East Bay Municipal Utility District*

EBMUD operates two wastewater facilities that serve the Camanche North Shore Recreation Area and Pardee Recreation Area in Amador County, which treat a combined 3.3 AFY. EBMUD has discussed development of a regional wastewater treatment facility with local jurisdictions to treat wastewater from these two facilities (Amador County Municipal Service Review 2014).

### *City of Ione*

The City of Ione operates the COWRP tertiary treatment facility and a secondary wastewater treatment plant. The City provides wastewater collection, treatment and disposal services to 1,715 connections, treatment for ARSA wastewater discharges, and recycled water to a local golf course.

- **City of Ione WWTP** – The City of Ione owns and operates a WWTP that collects and treats wastewater for property within its corporate city limits. Wastewater is treated to secondary standards using treatment ponds and then disposed of through percolation/evaporation ponds (KSD 2012). The City needs to expand the storage and disposal capacity of its wastewater operations to accommodate future development beyond its existing commitments made through development agreements. Plans include modification of current pond systems and the addition of spray irrigation. ADWF for 2013 was 0.42 MGD or 471 AFY and is expected to expand

to 1.34 MGD or 1,505 AFY by 2025 (Amador LAFCO 2014, 75). The City anticipates that 436 AFY of recycled water from this facility will be used in the future, leaving 1,069 AFY of potentially available recycled water in the future.

- **Castle Oaks Water Reclamation Plant** – The City also owns and operates COWRP, which accepts secondary effluent from ARSA and the Mule Creek State Prison and produces a disinfected tertiary Title 22 effluent suitable for unrestricted reuse to irrigate the golf course at the Castle Oaks residential development within the Ione city limits (RMC 2013). The Ione WWTP and COWRP are hydraulically connected with the Ione WWTP accepting backwash and drain water from COWRP and taking secondary effluent from ARSA and Mule Creek when this flow exceeds the irrigation demand of the golf course (Amador LAFCO 2014, 81). Annual wastewater flows for COWRP are currently 462 AFY and are projected to increase to 1,476 AFY in the future. The COWRP currently recycles and uses the entire 462 AFY and has plans to expand recycled water use with wastewater flow increases. As such, no additional recycled water is anticipated being available from this plant in the future.

### *City of Jackson*

The City of Jackson owns and operates a WWTP which discharges secondary-treated effluent to Jackson Creek. The WWTP has a capacity of 796 AFY and currently treats 527 AFY of wastewater (Aegis 2013, 4-7). Development in the greater Jackson area is projected to result in a need to treat and dispose of 753 AFY of municipal wastewater by 2025, but flows are not expected to exceed plant design capacity before 2035 (Amador LAFCO 2014, 119). The City of Jackson does not currently use recycled water, nor does it have plans to in the future.

The WWTP, as noted above, discharges the treated effluent into Jackson Creek, which flows to Lake Amador, Jackson Valley Irrigation District's (JVIDs) water supply reservoir. The Regional Water Quality Control Board and Department of Public Health have expressed concerns that this may result in concentrations of treated wastewater higher than 5 percent of flows in Jackson Creek (Jackson 2012). As a result, the City of Jackson has been directed to upgrade their WWTP to full tertiary status by March 2018 (Central Valley RWQCB 2013). While the capacity of the plant will not change, the increased treatment will allow for a wider variety of uses (Jackson 2012).

### *City of Plymouth*

The City of Plymouth's wastewater facility provides primary wastewater treatment prior to discharging the treated effluent through land disposal. Total current effluent flows at this facility are 135 AFY and are expected to grow to 909 AFY in the future. Plymouth is authorized to discharge the effluent to 125 acres of spray fields for disposal, of which 85 acres are usable for disposal (Amador LAFCO 2014, 161). It is estimated that this uses roughly 90 AFY of recycled water, which Plymouth will continue to use in the future. This leaves 819 AFY of potentially available recycled water in the future.

Currently, the City is working with Bella Victoria Family Vineyard on a program to supply recycled water to their vineyards adjacent to the City's wastewater treatment facility. The first phase of the project, at a cost of roughly \$1.6 million, will supply 200 acres with secondary treated recycled water (City of Plymouth 2014, personal communication). The second phase will serve an additional 200 acres and is anticipated to cost between \$600,000-700,000. This program will require the City of Plymouth to upgrade its treatment plant to secondary standards and would absorb the effluent associated with growth for the next 40 years (City of Plymouth 2014, personal communication). As such, there is not anticipated to be any secondary treated recycled water available from the City of Plymouth in the future, beyond what it planned to be provided for local agricultural use.

### *Mokelumne Hill Sanitary District*

MHSD provides wastewater collection, treatment and disposal services to the unincorporated community of Mokelumne Hill (RMC 2013). The MHSD wastewater treatment plant treats to secondary standards and has an ADWF of 0.04 MGD or approximately 45 AFY, with an expected 56 AFY by 2035 (MWH 2009, 43). Treated effluent is currently stored in the storage pond until summer, when it is used to irrigate the spray disposal field which is used for cattle grazing. Recycled water is expected to be used for irrigation purposes in the future, so no additional available recycled water is anticipated in the future.

### *San Andreas Sanitation District*

SASD provides wastewater collection, treatment and disposal services to the community of San Andreas and neighboring areas. The plant treats wastewater to secondary levels and polishes the resulting effluent in three post-secondary treatment ponds. SASD is capable of discharging up to 1,681 AFY by land disposal and discharge into San Andreas Creek, which ultimately flows into the North Fork of the Calaveras River (MWH 2009, 42). SASD treats and discharges approximately 340 AFY of effluent, which is projected to reach 482 AFY in 2035 (MWH 2009). SASD does not currently use recycled water, nor does it have any plans to do so in the future.

### *Valley Springs Public Utility District*

VSPUD provides wastewater collection, treatment and disposal services to the unincorporated Valley Springs. VSPUD's treatment process includes the use of a treatment plant, pond processing, and disposal through evaporation and spray fields. The plant currently treats and discharges 67 AFY of wastewater to secondary standards, which is expected to expand to 187 AFY by 2025. Current discussions on future disposal methods include application for discharge permits and creation of a trench system for the spray fields (MWH 2009, 44-45). VSPUD does not currently use recycled water, nor does it anticipate using recycled water in the future.

### *Wallace Community Services District*

WCSD provides wastewater collection, treatment and disposal services to the gated community of Wallace Lake Estates and the unincorporated town of Wallace, but contracted with CCWD in 2009 for operation and maintenance of WCSD wastewater facilities (RMC 2013). The WCSD's wastewater treatment system operates at the tertiary treatment level treating an ADWF of 0.019 MGD or 21 AFY, reaching 179 AFY of wastewater treatment due to growth by 2035. WCSD does not currently use recycled water; currently, all treated effluent, which is roughly 20 AFY, evaporates, transports, or percolates into the soil from the storage reservoir (MWH 2009, 46). In the future, 179 AFY of recycled water is considered potentially available for use.

### *Overall Upper Watershed Wastewater Flows*

Based on the above data, the total amount of wastewater collected and treated currently by the agencies listed above is approximately 2,710 AFY. Of this, approximately 1,250 AFY is reclaimed and treated for use as an irrigation resource. The agencies above are projected to collect and treat approximately 8,300 AFY at build-out, which is around 2035 for most agencies, of which 4,745 AFY will be treated and utilized for irrigation and other recycled water uses. As shown in Table 2 below, this leaves approximately 3,600 AFY of recycled water that may be theoretically available in the future. Based on feasibility, cost, and other local considerations, roughly 3,500 AFY of recycled water is assumed to be available in the future, which includes 2,557 AFY of secondary treated effluent and 932 AFY of tertiary treated effluent. While small wastewater treatment plants are unable to provide the widespread benefits of larger wastewater treatment plants, they would provide opportunities for small scale projects through partnerships between local businesses and other local recycled water users.

**Table 2: Wastewater Flows and Potential Recycled Water in the Upper Watershed**

<b>Agency</b>	<b>WWTP</b>	<b>Treatment Level*</b>	<b>Disposal Method**</b>	<b>Current*** WW ADWF (AFY)</b>	<b>Current† Recycled Water (RW) Use (AFY)</b>	<b>Future†† WW ADWF (AFY)</b>	<b>Future†† RW Use (AFY)</b>	<b>Future†† Available WW (AFY)</b>
<b>AWA</b>	Lake Camanche WWTP	Secondary	Spray	56	56	110	110	0
<b>AWA</b>	Gayla Manor WWTP	Secondary	Subsurface and Spray	5.5	0	22	0	(theoretical) 22 (assumed) 0
<b>ARSA (City of Sutter Creek)</b>	City of Sutter Creek WWTP	Secondary	ARSA	<b>355</b>	151	1,023 (650 to Ione)	968 (650 to Ione)	(theoretical) 55 (assumed) 0
<b>CCWD</b>	La Contenta	Tertiary (Title 22)	Reclaimed	<b>225</b>	173	1,636	1,610	(theoretical) 26 (assumed) 0
<b>EBMUD</b>	Lake Camanche North Shore	Secondary	Spray	1.6	0	1.6 ^	0 ^	(theoretical) 1.6 (assumed) 0
<b>EBMUD</b>	Pardee Recreation Area	Secondary	Spray	1.7	0	1.7 ^	0 ^	(theoretical) 1.7 (assumed) 0
<b>City of Ione</b>	Secondary Treatment Plant	Secondary	Ponds	471	278	1,505	436	1,069
<b>City of Ione</b>	Castle Oaks Reclamation Plant (COWRP)	Tertiary (Title 22)	Reclaimed	462	462	1,476	1,476	0

**Table 2: Wastewater Flows and Potential Recycled Water in the Upper Watershed**

Agency	WWTP	Treatment Level*	Disposal Method**	Current*** WW ADWF (AFY)	Current† Recycled Water (RW) Use (AFY)	Future†† WW ADWF (AFY)	Future†† RW Use (AFY)	Future†† Available WW (AFY)
<b>City of Jackson</b>	City of Jackson WWTP	Tertiary (currently Secondary)	NPDES	527	0	753	0	753
<b>City of Plymouth</b>	City of Plymouth WWTP	Secondary	Spray	<i>135</i>	90 ^	909	90 ^	819
<b>MHSD</b>	Mokelumne Hill WWTP	Secondary	Reclaimed	<i>45</i>	45	56	56	0
<b>SASD</b>	San Andreas WWTP	Secondary	Spray & NPDES	<i>336</i>	0	482	0	482
<b>VSPUD</b>	Valley Springs WWTP	Secondary	Spray	<i>67</i>	0	187	0	187
<b>WCSD</b>	Wallace WWTP	Tertiary	Evaporation & Spray	<i>21</i>	0	179	0	179
<b>Total Upper Watershed</b>				<b>2,709</b>	<b>1,255</b>	<b>8,341</b>	<b>4,764</b>	<b>(theoretical) 3,595 (assumed) 3,489</b>

\* Secondary = Secondary Level Treatment for Land Disposal, Tertiary = Tertiary Level Treatment for Land Disposal

\*\* NPDES = Disposal to surface water via an NPDES permit, Reclaimed = Disposal of effluent via permitted reclaimed water uses, Spray = Disposal of effluent to above ground spray fields

\*\*\* Current volumes are from the year 2013. Italicized and bolded entries are from the years 2010 and 2011 or projected to 2013.

† Current volumes are based on the most recent available information.

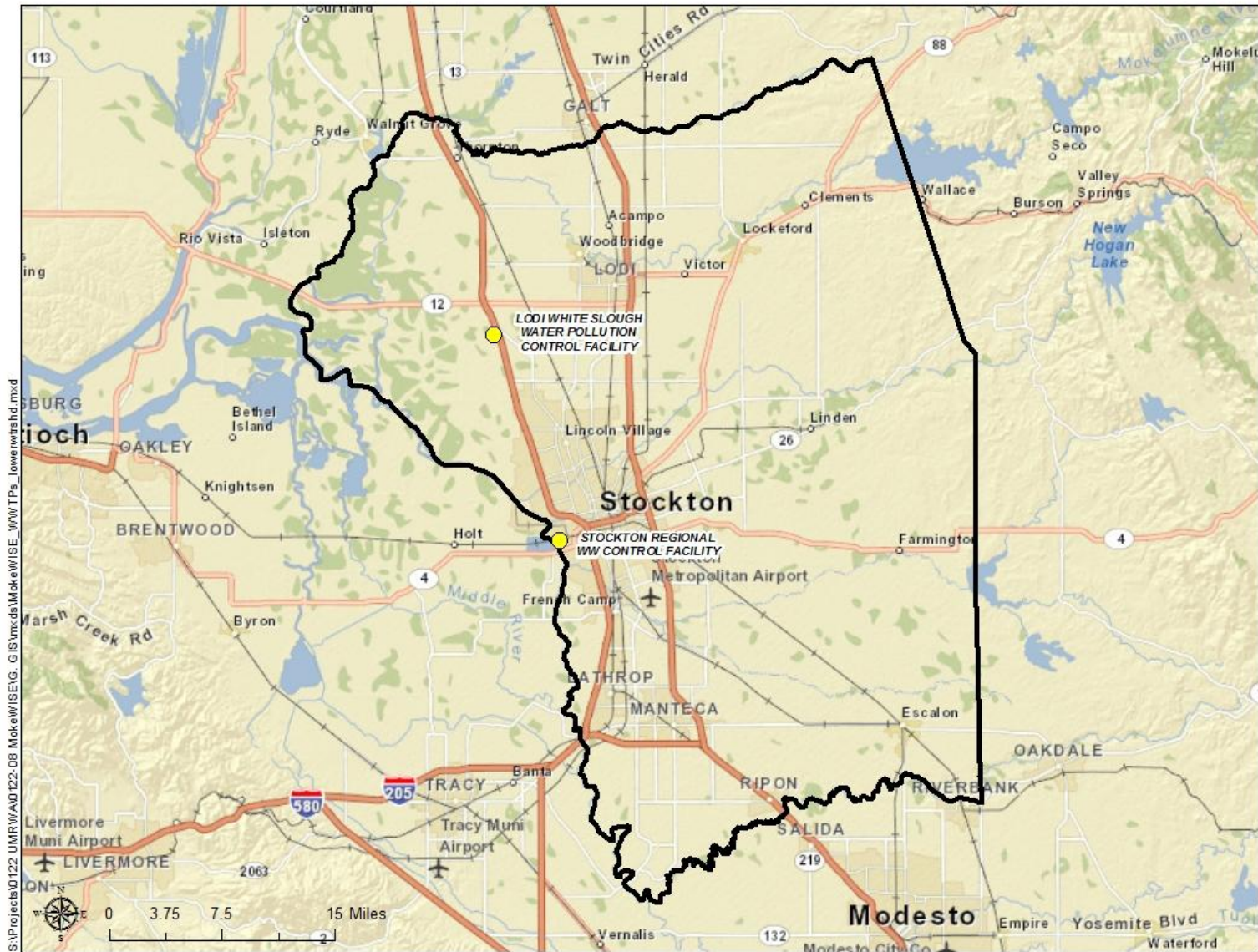
†† Future volumes vary among entities and range from the years 2025 to 2040.

^ Estimated number based on available information.

## Lower Watershed

The following agencies own and operate the major wastewater collection and treatment facilities in the lower watershed: the City of Stockton and the City of Lodi. Both cities operate tertiary treatment facilities and discharge some, if not all, of the treated effluent to surface water. Together, the facilities collect and treat approximately 37,000 AFY of wastewater, which is projected to increase to 58,892 AFY in 2035. Total planned recycled water use is projected to amount to 2,842 AFY in 2035, with the remaining 56,050 AFY of tertiary-treated recycled water planned to be discharged to surface waters. The two wastewater treatment plants that lie within this area are described in greater detail below. All flows associated with the lower watershed are summarized in Table 3. Figure 6 identifies the location of each of the treatment plants discussed in the following sections.

Figure 6: Wastewater Treatment Facilities in the Lower Watershed



S:\Projects\0122 UMR\WAD\122-08 MokeWISE\GIS\mxd\MokeWISE\_WWTPs\_lowerwatershed.mxd



### *City of Lodi*

The City of Lodi operates the White Slough Water Pollution Control Facility (WSWPCF) which currently treats approximately 7,100 AFY of wastewater, of which 1,642 AFY is used in the vicinity of WSWPCF for agricultural, aquacultural, and industrial uses. WSWPCF is capable of treating all wastewater flows to Title 22 tertiary standards and recently completed an upgrade which expanded capacity to 8.5 MGD (9,592 AFY) and allows the plant to meet future NPDES permit limits and long-term land management needs. The City currently discharges all wastewater effluent that is not used for recycled water into Dredger Cut, a slough flowing into the Delta (Lodi 2011, 23). It is anticipated that the City will use 2,842 AFY of recycled water in the future, which would theoretically leave 6,750 AFY of treated effluent available for reuse.

The City is considering an agricultural reuse project as part of its 2008 Reclaimed Water Master Plan. The project would provide approximately 3,700 AFY to agricultural and industrial customers adjacent to the WSWPCF (Lodi 2011,25). Therefore, of the 6,750 AFY of treated effluent that would theoretically be available in the future, 3,050 AFY is assumed to be available, after accounting for the agricultural reuse project.

### *City of Stockton*

The City of Stockton owns and operates the Regional Wastewater Control Facility (RWCF), which provides tertiary treatment year round and was upgraded in May 2006. The RWCF currently treats 29,950 AFY of wastewater and until recently provided approximately 100 AFY of recycled water for agricultural purposes nearby. Future increases in wastewater flows are expected to approximately follow the population growth rate and projected water use of the City of Stockton Municipal Utilities Department (COSMUD) service area, reaching an estimated 49,300 AFY in 2035 (Stockton 2011, 4-15).

The City of Stockton holds a Section 1485 water right, which allows any municipality that disposes of treated wastewater into the San Joaquin River to seek a water right to divert a similar amount of water, less losses, from the San Joaquin River or the Delta, downstream of the wastewater discharge point. Because of this water right, the City's water supply is connected to their wastewater discharge. While 49,300 AFY of treated effluent is theoretically available in the future, because this amount is being reused as part of the City's water right, none would be available for use in a recycled water project.

### *Overall Lower Watershed Wastewater Flows*

The total amount of wastewater collected and treated currently by the Cities of Lodi and Stockton is approximately 37,000 AFY. Of this, approximately 1,650 AFY is recycled for use. The cities are projected to collect and treat approximately 58,900 AFY at build-out, of which 2,842 is reasonably expected to be recycled. As shown in Table 3 below, this leaves approximately 56,050 theoretically available for recycling. However, based on currently planned projects and water right issues, 3,050 AFY of recycled water is assumed to be available in the future.

**Table 3: Wastewater Flows and Potential Recycled Water in the Lower Watershed**

<b>Agency</b>	<b>WWTP</b>	<b>Treatment Level*</b>	<b>Disposal Method**</b>	<b>Current*** WW ADWF (AFY)</b>	<b>Current† Recycled Water (RW) Use (AFY)</b>	<b>Future†† WW ADWF (AFY)</b>	<b>Future†† RW Use (AFY)</b>	<b>Future†† Available WW (AFY)</b>
<b>City of Lodi</b>	White Slough Water Pollution Control Facility (WSWPCF)	Tertiary (Title 22)	Reclaimed & NPDES	7,095	1,642	9,592	2,842	(theoretical) 6,750 (assumed) 3,050
<b>City of Stockton</b>	Regional Wastewater Control Facility (RWCF)	Tertiary (Title 22)	NPDES	29,950	0	49,300	0	(theoretical) 49,300 (assumed) 0
<b>Total Lower Watershed</b>				<b>37,045</b>	<b>1,642</b>	<b>58,892</b>	<b>2,842</b>	<b>(theoretical) 56,050 (assumed) 3,050</b>

\* Secondary = Secondary Level Treatment for Land Disposal, Tertiary = Tertiary Level Treatment for Land Disposal

\*\* NPDES = Disposal to surface water via an NPDES permit, Reclaimed = Disposal of effluent via permitted reclaimed water uses

\*\*\* Current volumes are from the year 2013. Italicized and bolded entries are from the years 2010 and 2011 or projected to 2013.

† Current volumes are based on the most recent available information.

†† Future volumes vary among entities and range from the years 2025 to 2040.

## EBMUD Service Area

The final area covered in this study is the group of wastewater collection service areas that lie within the EBMUD water service area, which together serve 1.34 million people (EBMUD 2011, 1-2). This area includes the following wastewater purveyors: EBMUD Special District Number 1 (SD-1), City of San Leandro, Dublin San Ramon Services District (DSRSD), Central Contra Costa Sanitary District (CCCSD), the Cities of Pinole and Hercules, Richmond Sanitary District, West County Wastewater District (WCWD), Rodeo Sanitary District (RSD), Oro Loma Sanitary District (OLSD), and Crockett Community Services District (CCSD). While these agencies are not within the watershed, if any of these agencies generated recycled water that offset demands which would otherwise be met through EBMUD potable water supplies, EBMUD demand for Mokelumne supply could potentially be reduced, freeing up additional Mokelumne supply for other uses.

Some of these districts, such as EBMUD SD-1, DSRSD, and Oro Loma Sanitary District operate and maintain intercepting sewers that receive and transport wastewater from collection systems that are owned and operated by communities within these districts. Alternatively, the communities of San Leandro, Pinole, Hercules, Richmond, and Rodeo own and maintain both the collection systems and the interceptor systems within their respective jurisdictions. Treated wastewater produced by wastewater treatment plants within the EBMUD water service area that is not recycled is discharged through pipelines or outfalls to San Francisco Bay, Suisun Bay, or San Pablo Bay and also provides a supply for recycled water programs.

Wastewater treatment flows in these WWTPs range from ADWF of 0.55 MGD to 74 MGD, with most treating less than 15 MGD or about 16,800 AFY. All of the wastewater treatment plants treat to secondary levels with some treating a portion of their flows to Title 22 tertiary standards for recycling purposes. Recycled water use is assumed to be the difference between the wastewater produced and the non-recycled wastewater treated and discharged (EBMUD 2011, 5-3, 5-4). Each of these agencies is described below and summarized in Table 4. Figure 7 identifies the location of each of the treatment plants discussed in the following sections.

Figure 7: Wastewater Treatment Facilities in EBMUDs Service Area\*



\* CCCSD and DSRSD WWTPs, while outside of EBMUDs service area, are owned by agencies whose potable water needs are served by EBMUD.

### *Central Contra Costa Sanitary District*

Located in Martinez, CCCSD operates a wastewater facility that treats wastewater to a secondary level before discharging the majority of the treated effluent to Suisun Bay. A portion of the secondary effluent is treated to a tertiary level and reused for landscape irrigation, industrial processes, and plant operations (CCCSD 2014). The plant currently treats 41,474 AFY of wastewater to secondary levels and 1,841 AFY of treatment to tertiary levels. The plant is projected to treat 56,045 AFY of wastewater to secondary levels and 785 AFY to tertiary levels in 2040 (EBMUD 2011, 5-3). Future recycled water use is anticipated to be 785 AFY, leaving 55,260 AFY of potentially available recycled water.

### *Cities of Pinole and Hercules*

The Pinole/Hercules Water Pollution Control Plant (WPCP) treats wastewater from the cities of Pinole and Hercules. The WPCP has been upgraded from a primary to a secondary treatment facility (City of Pinole 2014). The majority of flows are treated to secondary levels; however, flows in excess of 10.3 MGD do not receive secondary treatment and are blended with secondary effluent, disinfected and discharged to San Pablo Bay via Rodeo Sanitary District's outfall and its own Emergency Outfall (HDR 2013, 1). Currently, the WPCP treats 3,923 AFY of wastewater and is projected to treat 4,484 AFY by 2040. The cities anticipate that 4,147 AFY will be used as recycled water, leaving 337 AFY of potentially available recycled water.

### *Richmond Sanitary District*

The Richmond WWTP treats water to secondary levels and then discharges to the San Francisco Bay through a joint outfall with WCWD (Contra Costa LAFCO 2014). This WWTP currently treats 9,528 AFY of wastewater and does not currently recycle water nor have plans to expand or update the plant for tertiary treatment (EBMUD 2011, 5-3).

### *City of San Leandro*

The San Leandro Water Pollution Control Plant (WPCP) cleans 5 MGD of wastewater to a secondary level and disposes of this flow to the San Francisco Bay (San Leandro 2014). A portion of the wastewater is treated to tertiary standards and used for golf course irrigation. As of 2010, the plant was treating approximately 5,605 AFY of wastewater and is expected to treat 7,846 AFY by 2040 (EBMUD 2011, 5-3). The City anticipates using 5,885 AFY of recycled water in the future, leaving 1,961 AFY of recycled water potentially available for use (EBMUD 2011, 5-3).

### *Crockett Community Services District*

CCSD has two Sanitary Departments which have separate wastewater systems and serve the unincorporated Crockett and Port Costa communities. The Crockett Sanitary Department (CSD) is responsible for the collection system in the town of Crockett and issues related to

the Philip F. Mead Treatment Facility, which is jointly used with the C&H Sugar Company. The plant treats wastewater generated in the sugar refining process and pretreated domestic wastewater. Secondary treated effluent is discharged into the Carquinez Strait tributary to the San Francisco Bay (Contra Costa LAFCO 2014, 171172). The current ADWF is 0.7 MGD or 785 AFY, and is projected to remain constant through 2040. Recycled water is not currently used, nor are there plans for use in the future.

### *Dublin-San Ramon Sanitary District*

DSRSD owns and operates a regional WWTP, which treats wastewater from Dublin, South San Ramon, and Pleasanton. The wastewater treatment plant includes conventional secondary treatment facilities. A portion of the secondary effluent from the WWTP is treated further to produce Title 22 disinfected tertiary recycled water. Wastewater that is not recycled is discharged into the San Francisco Bay through a pipeline owned by the Livermore-Amador Valley Water Management Agency (LAVWMA). In 2010, DSRSD measured 16,309 AFY of treated effluent, of which 2,977AFY was reused (DSRSD 2011, 98). DSRSD projects that by 2035, the treatment plant will treat approximately 21,000 AFY of wastewater, all of which is anticipated to be recycled, and thus, not considered available for use by the MokeWISE program.

### *EBMUD*

EBMUD's wastewater service district (known as SD-1) provides primary and secondary wastewater treatment, followed by disinfection, dechlorination, and discharge via a deep-water outfall one mile off the East Bay shore into San Francisco Bay (EBMUD 2011, 5-7). The EBMUD Main WWTP currently treats an ADWF of approximately 83,000 AFY and is projected to maintain this level of treatment and discharge through 2040. EBMUD anticipates that 7,510 AFY of recycled water from this facility will be used in the future, leaving 75,437 AFY of recycled water potentially available for use in the future.

### *Oro Loma Sanitary District*

The Oro Loma WWTP is jointly owned by OLSD and Castro Valley Sanitary District and treats wastewater to a secondary level. Treated effluent is disposed of through a collectively-owned discharge pipe into the deep waters of San Francisco Bay (Oro Loma 2013). A portion of the secondary treated effluent is sent to the Sky West Golf Course and used for irrigation purposes. In total, the Oro Loma WWTP treats 15,132 AFY of wastewater and is expected to treat 19,055 AFY by 2040 (EBMUD 2011, 5-7). The City currently uses 291 AFY of recycled water, which it is expected to maintain in the future (EBMUD 2011).

### *Rodeo Sanitary District*

The RSD Wastewater Treatment Facility treats wastewater to secondary levels and discharges treated effluent to San Pablo Bay via a joint outfall with the Pinole-Hercules WPCP (Contra Costa LAFCO 2014). The RSD treatment facility currently treats 615 AFY of

wastewater and expects to increase wastewater treatment to 785 AFY in the future (EBMUD 2011, 5-3). RSD does not currently use recycled water, nor does it have plans to in the future (EBMUD 2011).

### *West County Wastewater District*

WCWD owns, operates, and maintains a Water Pollution Control Plant (WPCP) with a capacity of 12.5 MGD ADWF. The WPCP treats an average of 6.6 MGD or approximately 7,400 AFY of water to secondary treatment level. WCWD's final effluent is pumped to EBMUD's Richmond Advanced Recycled Expansion (RARE) facility and North Richmond Water Reclamation Plant (NRWRP) for additional treatment and reuse by Chevron's boiler and cooling tower facilities (Carollo 2013, 1). The WCWD WPCP is projected to treat 8,967 AFY of wastewater beginning in 2015 and through 2040, all of which will be recycled (EBMUD 2011, 5-7).

### *Overall EBMUD Service Area Wastewater Flows*

Based on the above data, the total amount of wastewater collected and treated currently by the agencies in the EBMUD water service district is currently 183,718 AFY. Of this, approximately 18,400 AFY is currently used as a recycled water source. The agencies above are projected to collect and treat approximately 211,400 AFY by 2040, of which 48,559 AFY will be treated and utilized as recycled water. As shown in Table 4 below, this leaves 162,857 AFY of treated effluent that is theoretically available as recycled water.

It is understood that the 162,857 AFY that is theoretically available as recycled water in the future is not realistic, largely due to the costs and the regulatory structure required to implement this amount. In 2008, EBMUD developed the Water Supply Management Program 2040 (EBMUD 2012c), which included an assessment of the potential recycled water market. The assessment estimated the recycled water demand as a percentage of average potable water demand, excluding users with potential demands less than 1.5 AFY. The results indicate that the potential future demand associated with existing accounts is approximately 33,500 AFY, comprised of 22,000 AFY for irrigation of public or common areas, 9,500 AFY for indoor industrial use, and 2,000 AFY of indoor commercial use (EBMUD 2012c, 4-8). Due to the lack of available information on projected water demands for future users, recycled water demand estimates for potential future users were not developed. The 33,500 AFY amount has been provided in this document to help benchmark the recycled water use that could potentially be available.



**Table 4: Wastewater Flows and Potential Recycled Water in the EBMUD Service Area**

Agency	WWTP	Treatment Level*	Disposal Method**	Current*** WW ADWF (AFY)	Current† Recycled Water Use (AFY)	Future†† WW ADWF (AFY)	Future†† RW Use (AFY)	Future†† Available WW (AFY)
<b>Central Contra Costa Sanitation District</b>	CCCSD WWTP	Secondary Tertiary (Title 22)	Reclaimed & SW Discharge	41,474	1,841	56,045	785	55,260
<b>Cities of Pinole and Hercules</b>	Pinole-Hercules WWTP	Secondary	Reclaimed & SW Discharge	3,923	0	4,484	4,147	337
<b>Richmond SD</b>	Richmond WWTP	Secondary	NPDES	9,528	0	9,528	0	9,528
<b>City of San Leandro</b>	San Leandro Water Pollution Control Plant (WPCP)	Secondary Tertiary (Title 22)	Reclaimed & SW Discharge	5,605	4,203	7,846	5,885	1,961
<b>Crockett Community Services District DSRSD</b>	Philip F Mead Wastewater Treatment Plant	Secondary	SW Discharge	785	0	785	0	785
<b>EBMUD SD-1</b>	Regional Wastewater Treatment Facility	Secondary Tertiary (Title 22)	Reclaimed & SW Discharge	16,309	2,977	20,974	20,974	0
<b>Oro Loma SD</b>	Main WWTP	Secondary Tertiary (Title 22)	Reclaimed & SW Discharge	82,947	1,681	82,947	7,510	75,437
<b>Rodeo SD</b>	Oro Loma WWTP	Secondary	Reclaimed & SW Discharge	15,132	291	19,055	291	18,764
<b>West County WD</b>	Rodeo Wastewater Treatment Facility	Secondary	SW Discharge	785	0	785	0	785
<b>West County WD</b>	WCWD WWTP	Secondary Tertiary (Title 22)	Reclaimed & SW Discharge	7,398	7,398	8,967	8,967	0
<b>Total EBMUD Service Area</b>				<b>183,718</b>	<b>18,391</b>	<b>211,416</b>	<b>48,559</b>	<b>162,857 (theoretical) &lt;162,857 (assumed) †††</b>

\* Secondary = Secondary Level Treatment for Land Disposal, Tertiary = Tertiary Level Treatment for Land Disposal

\*\* NPDES = Disposal to surface water via an NPDES permit, Reclaimed = Disposal of effluent via permitted reclaimed water uses

\*\*\* Current volumes are from the year 2013. Italicized and bolded entries are from the years 2010 and 2011 or projected to 2013.

† Current volumes are based on the most recent available information.

†† Future volumes vary among entities and range from the years 2025 to 2040.

††† **EBMUDs WSMP** 2040 cites 33,500 AFY as the potential annual recycled water demand (EBMUD 2012c).

## Combined Flows in the Upper and Lower Watershed and EBMUD Retail Service Area

### Current Recycled Water Use

The amount of wastewater currently being treated and discharged is estimated to be roughly 223,500 AFY, as indicated in Table 5. Of this amount, approximately 21,000 AFY is currently being reused for irrigation, cooling, or other purposes within the EBMUD water service area and the upper and lower watersheds.

**Table 5: Recycled Water Currently Used within the Upper and Lower Watersheds and EBMUD's Service Area**

Region	Current* WW ADWF (AFY)	Current† Recycled Water (RW) Use (AFY)
<b>Total Upper Watershed</b>	2,709	1,255
<b>Total Lower Watershed</b>	37,045	1,642
<b>Total EBMUD Water Service Area</b>	183,718	18,391
<b>Total</b>	<b>223,472</b>	<b>21,288</b>

\* Current values are based on the most recent available information and range from years 2010 to 2013.

† Current values are based on the most recent available information.

### Future Recycled Water Available

Recycled water theoretically available for use in the future is calculated to be 222,511 AFY, as shown in Table 6 below. Due to challenges and constraints as outlined in the following section, the amount assumed available in the future is reduced to approximately 170,000 AFY. These were calculated by taking the difference between projected future treated wastewater treatment effluent and anticipated recycled water use in the future.

**Table 6: Recycled Water Assumed Available for the MokeWISE Program**

Region	Future†† WW ADWF (AFY)	Future†† RW Use (AFY)	Available WW (AFY)
<b>Total Upper Watershed</b>	8,341	4,746	(theoretical) 3,595 (assumed) 3,489
<b>Total Lower Watershed</b>	58,892	2,842	(theoretical) 56,050 (assumed) 3,050
<b>Total EBMUD Retail Service Area</b>	211,416	48,559	(theoretical) 162,857 (assumed) <162,857
<b>Total</b>	<b>278,649</b>	<b>56,147</b>	<b>(theoretical) 222,502</b> <b>(assumed) &lt;169,396</b>

†† Future values vary among entities and range from 2025 to 2040.

## Summary of Potential Recycled Water Supplies

Recycled water potentially available for the MokeWISE program is estimated to be 222,500 AFY. However, due to constraints and challenges associated with treating and delivering recycled water, the total available decreases to approximately 169,400 AFY. This includes an estimated 126,720 AFY in secondary treated recycled water and roughly 42,680 AFY in tertiary treated recycled water available. Future recycled water opportunities within the upper and lower watersheds accounts for roughly 6,500 AFY of the total recycled water potentially available, while the remaining approximately 162,900 AFY is generated in the EBMUD retail service area.

## Challenges with Maximizing Recycled Water Use

Challenges associated with the use of recycled water as a supply in the MokeWISE program are listed below. These challenges will limit the ability to implement recycled water as part of the MokeWISE process.

- **Timing and storage.** Recycled water use can be limited by the timing of supply and demand. While supply is available year-round, demand is often limited to the summer months, particularly if the recycled water demand is largely irrigation. Because of this discrepancy in the timing of supply and demand, storage is needed. However, storage can be costly and space for storage limited, particularly in urban areas and in areas with limited groundwater recharge ability.
- **Economic feasibility.** Recycled water projects can be costly, potentially limiting the ability of agencies implement projects and support ongoing operation and maintenance costs. While there are various funding opportunities available to help offset initial capital costs, agencies may reach a point of diminishing returns on recycled water projects. That is, the marginal cost of implementing the last few recycled water projects may be significant and those projects may not be economically feasible. While this point of diminishing returns may change over time as technology advances, some of the recycled water theoretically available for MokeWISE may not be economically feasible.
- **Coordination costs.** Many recycled water projects require multiple agencies to implement. Coordination costs may be significant in large-scale projects that require multiple agencies. For example, while there is roughly 163,000 AFY theoretically available within the EBMUD water service area, only about 75,500 AFY of that is from EBMUD's Main WWTP. Coordination with nine agencies would be required to utilize the 163,000 AFY. This level of coordination may significantly limit the quantity of recycled water that could realistically be achieved.
- **Infrastructure requirements.** In the case of EBMUD, it is difficult to retrofit facilities already using EBMUD potable water. Because infrastructure relies on current demands in established areas, issues may arise if potable demands decrease.

Furthermore, the EBMUD service area is not planned for much growth that could use recycled water, as the majority of planned growth is infill and densification.

- **Benefit allocation.** Increasing recycled water use outside of the Mokelumne River watershed could potentially create issues with how benefits are apportioned within the watershed. For example, recycled water use in southern California has supported additional growth rather than reducing imports from other regions.
- **Market potential.** Recycled water projects can only be implemented if sufficient market demand exists to use the supply. Recycled water is primarily used for nonpotable, outdoor demands, which represent a subset of total demand. While recycled water can also be used to meet potable demands through indirect or direct potable reuse, regulatory requirements for potable reuse are currently evolving in California, adding some uncertainty to the feasibility of implementation, particularly given high costs of treatment to potable quality. Depending on the extent of market potential, the amount of recycled water that can be used within the planning horizon of the MokeWISE program may change.
- **Local considerations.** Each local agency has a unique setting which must be considered prior to implementing recycled water projects. For example, the City of Stockton produces 49,300 AFY of treated effluent that could theoretically be reused. However, due to the structure of the City's water rights, this amount would result in a need to secure additional supplies and would therefore not generate a net increase in available supply. Additionally, some agencies overlap with the EBMUD service area. Recycled water projects would need to be implemented within the overlap with the EBMUD service area to create benefits to the Mokelumne River watershed.
- **Scalability.** Small wastewater treatment plants may provide recycled water that is potentially available in the future. For instance, AWA's leachfields produce small quantities and are not proximate to potential recycled water customers. As such, projects involving recycled water from these leachfields are considered infeasible.
- **Groundwater basin proximity.** Recycled water could potentially be used to recharge the Eastern San Joaquin Groundwater Basin. However, feasibility of a recycled water recharge project may depend on the origin of the recycled water. Because of the proximity to the Eastern San Joaquin Groundwater Basin, recycled water from the lower watershed would likely be the most feasible for use in a recharge project. Because Stockton's assumed available supply is 0 AFY, only the 3,700 AFY of recycled water from Lodi or other valley cities could potentially be used for recharge. While recycled water supplies from EBMUD and the upper watershed could be used for recharge, this supply would only be feasible through an exchange.
- **Downstream impacts.** Recycled water, particularly on the municipal scale, must consider the downstream impacts. As with agricultural drainage water, reuse of recycled water could decrease this source for downstream users, thereby potentially decreasing the amount of water available for downstream users.

## Opportunities for Maximizing Recycled Water Use

The following are potential opportunities for maximizing recycled water use. These examples can be considered when discussing potential MokeWISE projects and programs.

- **Non-potable uses.** The use of recycled water for non-potable uses such as irrigation and toilet flushing is becoming increasingly common, and there is likely demand for expanded use of recycled water for these purposes. Use of recycled water for non-potable purposes requires a lower level of treatment than other potential uses of recycled water, such as indirect or direct potable reuse, though infrastructure requirements may be more significant. Dual-pipe systems could be used to support recycled water use in urban and suburban infill areas.
- **Saline intrusion barrier.** There are a number of areas within the San Joaquin Valley that are experiencing or are expected to experience saline intrusion, resulting in degradation of groundwater supplies. Wastewater agencies adjacent to areas experiencing saline intrusion could inject recycled water into the groundwater basin to provide a barrier against saline intrusion.
- **Indirect potable reuse/direct potable reuse.** Regulations are currently in place allowing indirect potable reuse of recycled water via groundwater recharge, and such programs could be implemented to develop this practice within the MokeWISE region. Surface water augmentation regulations for indirect potable reuse and state guidelines for direct potable reuse are expected in 2016, which may enable expanded use of recycled water for potable purposes.
- **Direct injection.** Recycled water could be directly injected into the groundwater basin to help stabilize groundwater levels and offset Mokelumne River water use.

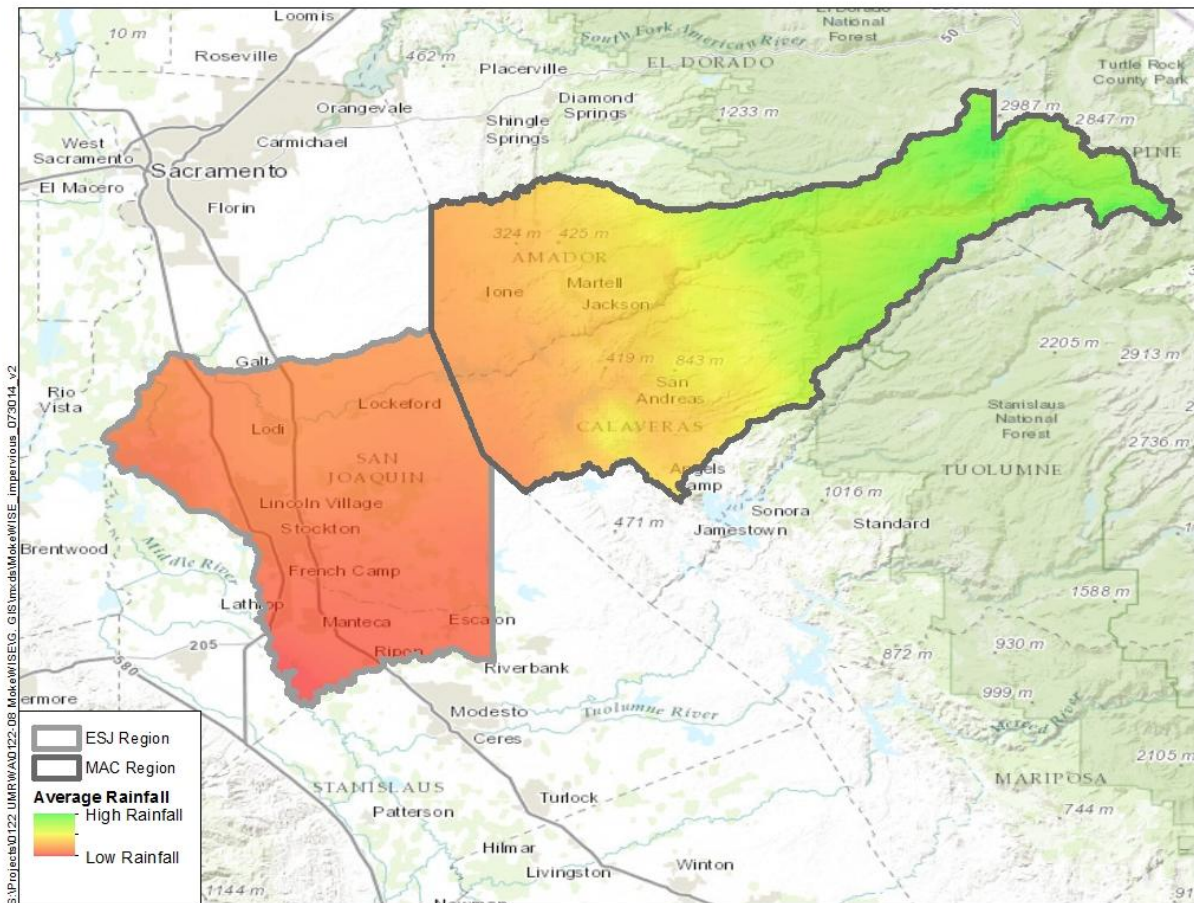
## Stormwater

Stormwater is precipitation, including rain, sleet, and melting snow, that runs off impervious surfaces. There is significant rainfall within the Mokelumne watershed, but it is highly variable and seasonal, with most precipitation occurring between November and May and very little occurring from late spring to fall. Greater rainfall typically occurs in the eastern portion of the Mokelumne River watershed (Sierra Foothills), compared to the western portion (San Joaquin Valley), as shown in Figure 8. Stormwater runoff that is not currently captured or infiltrated to groundwater may be available for a MokeWISE project.

In order to identify the potential supply available from stormwater capture, the amount of stormwater runoff that is not captured or infiltrated was estimated. For residential areas in the upper and lower watersheds, this was estimated by identifying impervious areas and estimating the average annual rainfall and snowmelt in those areas and assuming that some residential homes would participate in a rain barrel program. On a large-scale, stormwater from the municipal systems in Lodi and Stockton was estimated; it was assumed that municipal systems in the upper watershed would not contribute a substantial amount of stormwater for the MokeWISE program. As a final step, large-scale and small-scale stormwater capture programs were evaluated and existing stormwater programs in the MAC and ESJ regions were reviewed.

The EBMUD service area is not considered in this analysis because EBMUD is currently embarking on a study that will calculate theoretical stormwater supplies available within the EBMUD service area (see Appendix A for scope of work). EBMUD anticipates dividing the service area into two regions based on rainfall and will estimate monthly rainfall in a variety of year types, taking into account two climate change scenarios. For each region, EBMUD anticipates identifying the number and average property size, as well as the area of municipal open space, to develop an estimate of the amount of stormwater that could theoretically be captured within the EBMUD service area. This study is currently underway and is anticipated to be complete in spring 2015. If possible, results from that study will be incorporated into this analysis as appropriate.

**Figure 8: Average Rainfall in the Region**



## Potential Stormwater Capture

### Identification of Impervious Areas

In general, only precipitation that falls on impervious surfaces is available for capture and potential reuse. Impervious areas include streets, roads, parking lots, populated areas, rooftop, and other surfaces. In developed areas, stormwater may be collected and conveyed through a network of storm drains which eventually discharge to local creeks or the river. Rainfall reaching pervious areas tends to infiltrate and supplement the groundwater supply, and could not be readily captured for alternate use. Therefore, areas with the greatest concentrations of impervious surfaces have the greatest potential for stormwater capture and reuse. To determine the extent of impervious area in the region, land use data was acquired from the USGS's 2011 update to the National Land Cover Database (NLCD). The 30 meter resolution dataset displays the impervious land contained within each cell as a percentage. For example, an area designated as 80 percent

impervious is, on average, 20 percent pervious area with the remaining area being impervious. Masking the dataset to the MAC and ESJ regions and applying zonal statistics tools in GIS provided the following results.

Total Area of MokeWISE Region: 1,559,235 acres

Average Percent of Impervious Area in the Region: 3.25%

Total Impervious Area in the Region: 50,657 acres

As shown in Figure 9, areas with high concentrations of impervious area tend to be more urban in nature, such as the cities of Stockton, Lodi, and Manteca. These communities have more paved areas, buildings, and developed areas compared to communities that are more rural in nature.





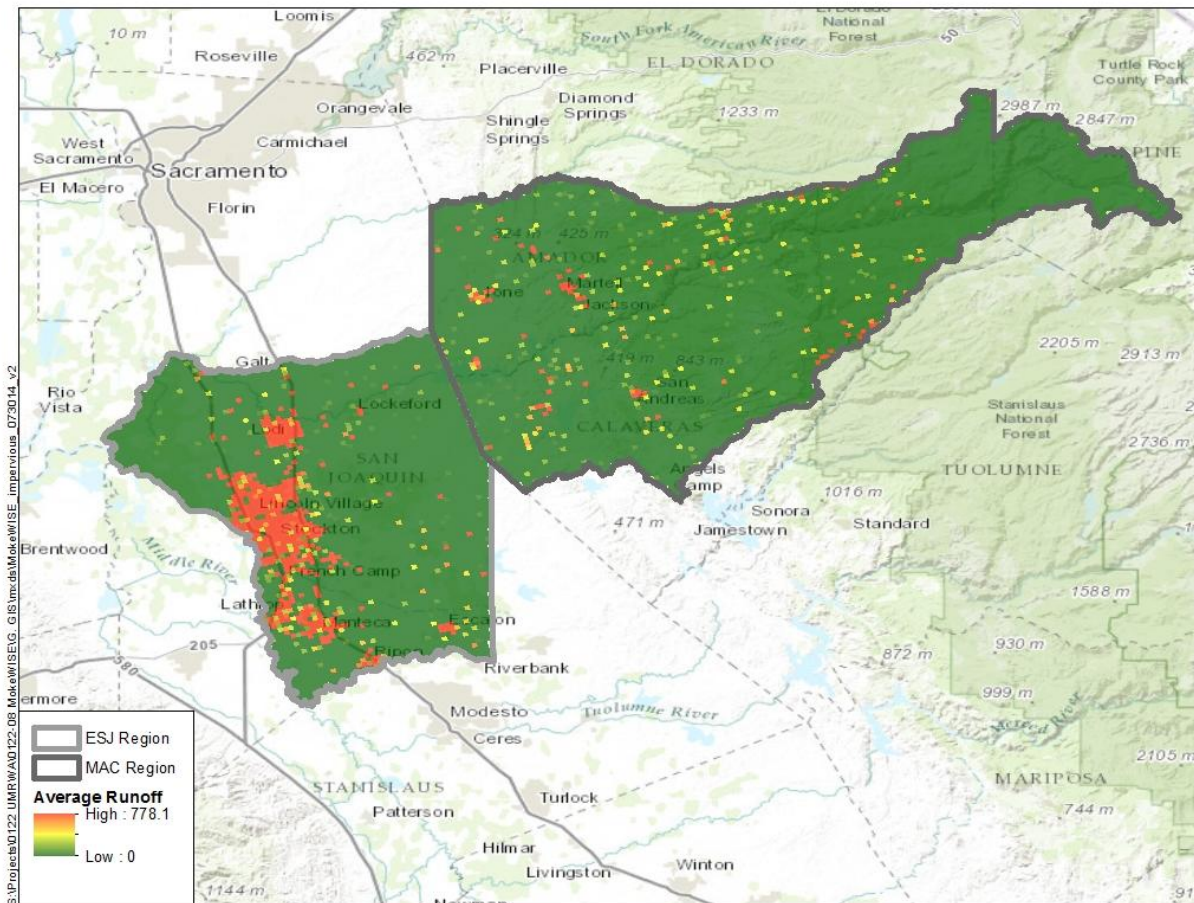
Conservation Service Snow Course (SNOWCOURSE), Western Regional Climate Center (WRCC), miscellaneous long-term precipitation storage gage stations, and others (NACSE, 2012). Using the PRISM precipitation dataset and the previous evaluation of impervious area in the region, the following rainfall estimates were determined for the region. These values were calculated by multiplying the precipitation raster dataset by the impervious area dataset.

Mean Precipitation per Year in the Region: 3,839,900 acre-feet per year (AFY)

Mean Stormwater Runoff per Year on Impervious Surfaces: 72,964 AFY

As shown in Figure 10, stormwater runoff capture and reuse has greater potential in the more populated areas of the ESJ Region, with some localized areas throughout the MokeWISE region as a whole. Because capturing all of the 72,964 AFY of available stormwater is infeasible, further analysis was conducted to determine the amount of potentially feasible stormwater available to be captured within residential areas and by municipal systems.

**Figure 10: Average Stormwater Runoff in the Region**



### Potential Stormwater within Residential Areas

To determine the amount of stormwater potentially available in residential areas within the watershed, the cities of Jackson and Stockton were assumed to be representative of the upper and lower watersheds, respectively.

Zoning data from these two cities and level of development data from the NLCD was used to determine the percentage of residential developed area. The percentage for Stockton was calculated to be 45.41 percent and the percentage for Jackson was 61.84 percent (see Table 7). These percentages were applied to the total developed area with each watershed to determine the total area of residential developed area within the upper and lower watersheds. Total residential developed area within the upper watershed was calculated to be roughly 3,030 acres and approximately 33,170 acres in the lower watershed (see Table 8).

**Table 7: Metrics for Upper and Lower Watershed Representative Cities**

<b>Metric</b>	<b>Stockton</b>	<b>Jackson</b>
<b>Area of City (acres)</b>	112,745	2,280
<b>Average Total Area of Residential (acres)</b>	14,436	1,100
<b>Total Area of Developed Area (acres)</b>	31,790	1,790
<b>Percent of Developed Area that is Residential</b>	45.41%	61.84%
<b>Average Residential Parcel Size (acres)</b>	0.13	0.82

Sources: City of Jackson 2008, City of Stockton 2013.

For the purposes of this analysis, it was assumed that 25 percent of all residential parcels would participate in a rain barrel program by installing a barrel or other stormwater capture and reuse system. Based on data from Jackson and Stockton, the average residential parcel size in the upper watershed was estimated to be 0.82 acres and 0.13 acres in the lower watershed (see Table 7). Assuming 25% of the total residential area would participate in a program, 760 acres in the upper watershed and 8,290 acres in the lower would participate in a rain barrel program (see Table 8). Assuming that 10% of a residential parcel is roof space, the total residential acreage in each watershed that would be available to capture stormwater is 829 acres in the lower watershed and 76 acres in the upper watershed.

**Table 8: Metrics for Calculating Residential Area in Upper and Lower Watersheds**

<b>Metric</b>	<b>Lower Watershed</b>	<b>Upper Watershed</b>
<b>Total Developed Area (acres)</b>	73,030	4,900
<b>Total Area of Developed that is Residential (acres)</b>	33,170	3,030
<b>Total Area of Residential Developed Participating in a Rain Barrel (acres)</b>	8,290	760
<b>Total Area of Roofs within Residential Developed Participating in a Rain Barrel (acres)</b>	829	76

Source: NLCD 2011, City of Jackson 2008, City of Stockton 2013.

Monthly data from two stations located in the upper watershed (Camp Pardee and West Point) and from two stations in the lower watershed (Lodi and Stockton Fire Station 4) were averaged to obtain the average monthly rainfall for the upper and lower watersheds. To determine the amount of stormwater that could potentially be captured in irrigation months through residential rain barrels or other rainwater capture and reuse systems, the average monthly rainfall was obtained from CDEC (see Table 9).

**Table 9: Average Monthly Rainfall in Upper and Lower Watersheds**

Month	Average Rainfall (inches)	
	Lower Watershed	Upper Watershed
January	3.25	5.47
February	2.69	4.71
March	2.30	4.35
April	1.41	2.64
May	0.44	1.01
June	0.12	0.33
July	0.05	0.09
August	0.06	0.12
September	0.23	0.34
October	0.74	1.52
November	1.84	3.37
December	2.87	4.70
<b>Total</b>	<b>16.00</b> <b>1.33 (feet)</b>	<b>28.65</b> <b>2.39 (feet)</b>

Source: CDEC 2014

To determine the amount of stormwater that could potentially be captured all year, assuming adequately-sized rainwater capture and reuse systems and sufficient demand for captured supplies, the average yearly rainfall was used (Table 9). Multiplying the average yearly rainfall by the acreage of the residential developed roofing area that would participate in a rain barrel program yields the stormwater that could potentially be captured in the upper and lower watersheds.

Upper Watershed: 180 AFY

Lower Watershed: 1,103 AFY

Assuming 50 percent losses due to evaporation, transpiration, and minimal recharge, the total amount of stormwater available to be captured and reused in residential areas within the watershed is approximately:

Upper Watershed: 90 AFY  
Lower Watershed: 551.5 AFY  
Total: 641.5 AFY

## Potential Stormwater from Municipal Systems

### *City of Stockton*

The City of Stockton monitors the quality of its stormwater, but does not have a system for measuring quantity (City of Stockton 2014a personal communication). To estimate the amount of stormwater discharged through the municipal system and therefore potentially available to be used, the acreage of developed commercial and industrial land was determined and multiplied by the average annual rainfall in the City of Stockton. The precipitation gage at the Stockton Fire Station 4 indicates that the average annual rainfall is 15.67 inches, or 1.31 feet. There are roughly 17,400 developed acres within the City of Stockton that are dedicated to commercial and industrial uses. This yields approximately 22,700 AFY of stormwater potentially available to the municipal system. Assuming 50 percent losses, the total potential amount of stormwater that is discharged through the City of Stockton's municipal system and that could be captured and reused is 11,370 AFY.

### *City of Lodi*

The City of Lodi discharges all of its stormwater through 18 outlets with pipes ranging in diameter from 8 to 72 inches (Black and Veatch 2003, 5-23). While some of the stormwater is discharged in Lodi Lake, the majority is discharged into the Woodbridge Canal, per the Storm Drainage Discharge Agreement between the two entities. This agreement allows the City to discharge a total maximum of 160 cubic feet per second (cfs), not to exceed 60 cfs per discharge site, during the winter (Black and Veatch 2003, 5-23). These rates are reduced to 40 cfs and 20 cfs, respectively, during the summer. Woodbridge Irrigation District (WID) charges the City of Lodi annually for discharging its stormwater. These rates are determined by multiplying the amount of rainfall per a given year by the area of the City (Woodbridge Irrigation District 2014, personal communication).

The City of Lodi is roughly 14 square miles, or 8,845 acres. The City's average annual rainfall from 2000-2010 was 16.97 inches, or 1.47 feet (NOAA 2014). This yields approximately 13,000 AFY of stormwater potentially discharged from the City of Lodi. However, because a portion of this amount is already considered in the residential analysis, the residential developed areas must be removed from the total acreage of the City. The total acreage of commercial and industrial areas within the City is roughly 4,830 acres, which yields a discharge of 7,100 AFY. Assuming 50 percent losses due to evaporation,

transpiration, and minimal recharge, the total potential amount of stormwater that is discharged through the City of Lodi's municipal system and that could be captured, treated, and reused is 3,550 AFY.

## **Existing and Potential Stormwater Programs**

### **Existing Stormwater Programs**

Most stormwater drainage systems are designed to capture and convey water away from people and property rather than for beneficial use. As stormwater flows across the ground, it picks up contaminants such as fertilizers, pesticides, dirt, and motor oil. Since stormwater can be a source of surface water and groundwater contamination, cities must comply with total maximum daily load (TMDL) implementation plans and applicable National Pollutant Discharge Elimination System (NPDES) requirements. To comply with state and federal requirements, cities typically develop Stormwater Management Programs to help protect rivers, both water supplies and valuable habitat areas.

For example, the City of Lodi published a Stormwater Development Standards Plan in 2008 to assist in the overall management and infrastructure planning for handling of stormwater runoff. The plan, which supplements the City's Stormwater Management Program from 2003, includes Best Management Practices (BMPs) in six program areas: public education and outreach, illicit discharge detection, public participation/involvement, construction site runoff control, post-construction runoff control, and pollution prevention (B&V 2003). The City has teamed with the local community under its Storm Drain Detectives program. A group of teachers, students, and community members, in partnership with the City of Lodi, monitor the effects of storm drain runoff that flows from streets and drains into Lodi Lake and the Mokelumne River. The City discharges some of its stormwater into the Mokelumne River and the WID Canal, and retains the rest of the stormwater in DeBenedetti Park and Pixley Park detention basins. The stormwater flow directed to the detention ponds is allowed to dissipate by evaporation and percolation (City of Lodi 2008). Because some of the water is allowed to percolate, there are groundwater recharge benefits which may be realized. As such, utilizing a portion of this water could decrease the amount of recharge that is currently occurring.

Similarly, the City of Stockton operates five detention basins that were initially designed for flood control and three additional detention basins maintained for water quality and flood control. The City, along with the urbanized areas of San Joaquin County, updated its Stormwater Management Plan in 2009 to comply with new federal regulations to eliminate or control the discharge of pollutants. The program includes volume reduction measures, which arose from the volume reduction requirement that specifies the use of low impact development (LID). The volume reduction measures are BMPs that can be used to direct, retain, reuse and/or infiltrate stormwater runoff (LWA 2009). These detention basins are



being used for recharge, similarly to how the City of Fresno and the Fresno Irrigation District use Leaky Acres.

Many cities are evaluating potential LID principles and techniques which can be used to design and construct sites that minimize soil compaction and imperviousness, preserve natural drainages, and result in improved water quality. For example, the City of Manteca has included LID recommendations in its 2013 Stormwater Management Plan. It anticipates LID principles will be required in all new development after updates to the statewide stormwater NPDES Phase II permit.

In the MAC Region, the City of Ione has an inadequate storm drainage system. According to the 2009 City of Ione General Plan, in older section of the City, there are limited or no storm drainage facilities, requiring the City to place temporary storm drainage structure to contain runoff. The City intends to correct these deficiencies. This could provide an opportunity for the implementation of LID measures or local, small-scale stormwater runoff capture and reuse.

Based on research of existing documents, there are currently no existing or planned stormwater capture, treatment and reuse programs occurring in the MokeWISE region.

### Potential Programs

Stormwater could potentially be captured through large-scale capture and treatment projects and/or small-scale onsite capture programs (such as rain barrels).

Small-scale programs could include utilizing low impact development (LID) principles and implementing onsite systems such as rain barrels and cisterns. LID could be used to recharge upper aquifers, but its primary benefit is in reducing peak attenuations of storm flows and improving runoff quality. Onsite rain barrels at the residential level could be widely implemented if incentives were offered to property owners.

Groundwater storage and/or recharge are potential uses of collected municipal stormwater within the lower watershed. Stormwater could be banked within the groundwater basin during the wet months and extracted during the dry months. Partnerships between local entities could help facilitate localized transfers between banked groundwater and surface water. In addition to the recharge infrastructure required, storage and conveyance infrastructure would be necessary to deliver the collected stormwater to any recharge sites.

The upper watershed is more rural residential in nature. As such, it is anticipated that onsite rainwater capture and use by individual residences would be the primary mechanism for rainwater capture and reuse in the upper watershed.

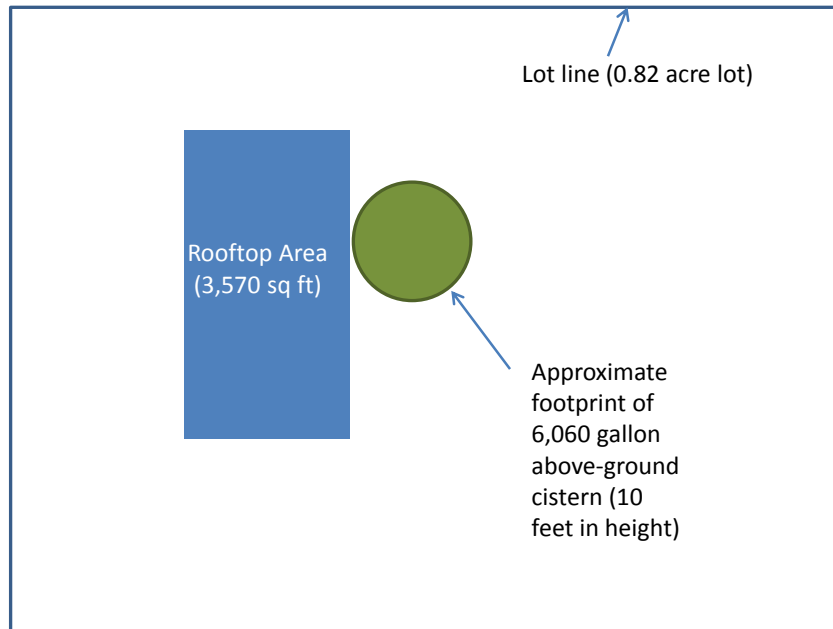
Captured rainwater can be used for outdoor irrigation and some indoor nonpotable uses. Indoor use of rainwater is typically regulated by the local health department, and allowable

uses vary, with approvals often occurring on a case-by-case basis. In California, rainwater has been used for indoor purposes such as toilet flushing and clothes washers. According to a 2011 study, the average single family home in northern California uses 295 gallons per household per day (gphd) (Aquacraft 2011, 128). Roughly 42% (125 gallons) of this total is for outdoor uses and 58% (171 gallons) is for indoor uses. Typically, approximately 20% of indoor use is for toilet flushing and 18% of indoor use is for clothes washing (Aquacraft 2011, 134). Assuming that a non-potable supply, such as rainwater, could be used for outdoor irrigation, toilet flushing, and clothes washing, the average single family northern California home could offset 190 gallons of potable water per day with rainwater if sufficient supplies and storage were available. Over the course of a year, this equates to approximately 69,350 gallons (0.2 AF).

As described previously, a typical residential parcel in the Jackson area is estimated to be 0.8 acres. It was assumed that approximately 10% of this area would be roof space; this corresponds to 0.082 acres, or 3,570 square feet. Assuming approximately 2.39 feet of precipitation falls in the upper watershed in an average year, and accounting for 50 percent losses, approximately 31,910 gallons (0.10 AF) of rainwater could be captured from a 3,570 square foot rooftop over the course of a year. This equates to 46 percent of estimated annual demand for non-potable supplies. This is a conservative estimate, as rooftop capture could have losses less than 50 percent. If rooftop systems were constructed on residential homes, water capture would likely be higher and annual water savings could be greater.

The wettest month is January, when irrigation needs are at their lowest. Of the 31,910 gallons of water available for capture over the course of the year, 19%, or 6,060 gallons (0.02 AF), falls in January. Assuming storage capacity would need to be sufficient to capture the quantity of rainfall experienced in January alone, a 6,060 gallon cistern would be required (Figure 11). Depending upon the desired configuration, this level of storage could be achieved with an above-ground cistern that is 28 feet in diameter and 10 feet in height.

**Figure 11: Approximate Dimensions of Required Storage**



### Summary of Potential Stormwater Supplies

Stormwater potentially available for the MokeWISE program comes from both residential areas and from municipal systems in Stockton and Lodi. Total stormwater potentially available for reuse within the upper and lower watersheds from both sources is estimated to be roughly 15,100 AFY. Stormwater that could potentially be captured and reused within residential areas is estimated to be 640 AFY. Stormwater capture from municipal systems is estimated to be 14,920 AFY. Residential areas within the upper watershed could potentially capture up to 90 AFY, while residential areas in the lower watershed could potentially capture 550 AFY, assuming rainwater capture occurs all year long. The cities of Stockton and Lodi potentially discharge 11,370 AFY and 3,550 AFY of stormwater within their municipal systems, respectively. These amounts could potentially be captured and reused.

### Challenges with Maximizing Stormwater Use

Challenges associated with maximizing the use of stormwater as a supply in the MokeWISE program are listed below. These challenges should be considered when discussing stormwater projects within the MokeWISE program.

- **Storage and timing of demand.** Challenges associated with storage and timing of demand are particularly relevant to small-scale residential stormwater reuse. Demand for reuse in residential areas is high in the summer irrigation months when precipitation is low, while precipitation is high during times when demand is low. While theoretically possible to capture all stormwater falling on residential property,

building the storage necessary to allow for year-round use of stormwater on a small scale is not realistic and inconsistent with the use of a typical rain barrel system.

- **Downstream impacts.** Stormwater reuse, particularly on the municipal scale, must consider the downstream impacts. As with agricultural drainage water, reuse of stormwater could decrease this source for downstream users, thereby potentially decreasing the amount of water available for downstream users.
- **Rain barrel requirements.** Residential stormwater capture is limited to rain barrel or cistern utilization, which has very specific use and specification requirements for capturing rooftop runoff. Due to the long dry season in California and the limited yield expected, implementing a program to maximize stormwater use on a residential scale can be space intensive and costly. Because of these challenges, typical rain barrel systems are small and very localized.
- **Treatment and conveyance for large-scale systems.** Stormwater can have a wide range of pollutants that make it unavailable for immediate use. Treatment of stormwater is often required prior to its reuse for certain activities. Designing and constructing a treatment system, or connecting drains to existing treatment systems, can provide challenges to large-scale stormwater reuse. Additionally, conveyance of treated stormwater may require modifications to existing conveyance infrastructure, or construction of new infrastructure.
- **Groundwater recharge.** Currently, some stormwater is likely helping to recharge the groundwater basin. Diverting this supply for another use aside from recharge could further impact the condition of the basin.

## Opportunities for Maximizing Stormwater Use

The following are potential opportunities for maximizing stormwater use. These examples can be considered when discussing potential MokeWISE projects and programs.

- **Large-scale detention basins.** Large-scale detention basins can be used to store municipal and/or residential runoff that can be treated and conveyed for other uses. Additionally, these basins can have flood control capabilities, which could allow supplies to be pumped and recharged, offsetting use of surface supplies.
- **Low impact development.** On a smaller scale, low impact development implemented in parking lots, office and residential complexes, and along roadsides can help stormwater infiltrate the groundwater basin. Agencies and local governments can redesign or require that new parking areas, parks, and playfields be used for recharge or have some recharge features and capabilities beyond what is currently required in stormwater discharge permits. Low-impact development elements could be required, recommended, or supported in local general plans and/or zoning ordinances.

- **Land purchases.** There may be opportunities to purchase land within areas experiencing frequent flooding or stormwater management issues for the purpose of groundwater basin recharge with stormwater.
- **Formal on-site reuse programs.** There may be opportunities to implement onsite stormwater reuse programs similar to existing programs in other areas around the state. For example, Los Angeles County has developed a local ordinance promoting stormwater capture, and the City of San Francisco has developed treatment standards for stormwater that are partially determined by end use.
- **Offset surface water.** Depending on the level of treatment, stormwater could be used to offset potable supplies in the future. While no regulations currently govern potable reuse of stormwater reuse, future regulations could allow stormwater to be used to offset Mokelumne or other surface water supplies. For instance, golf courses and other large water users could be mandated or encouraged to supplement potable supplies with stormwater for irrigation and other onsite uses.

## **Conservation and Efficiency**

Cities, agencies and districts throughout the project area are implementing aggressive conservation and efficiency programs as outlined in their 2010 UWMPs and Agricultural Water Management Plans (AWMPs). By reducing demands, conservation provides a direct one-to-one offset of potable or non-potable supplies, providing a valuable water supply management strategy with a potential benefit to Mokelumne River flows.

While conservation technically reduces water demands, for the purposes of the MokeWISE program, it is being treated as a potential supply option. As such, the following discussion refers to the amount of water available through conservation as opposed to the demand reduction achievable through conservation. Throughout the water industry, conservation is at times referred to as a demand reduction and at times as a supply; both are considered correct based on industry standards.

The amount of supply potentially available through conservation was determined by quantifying water that could be conserved through the expansion of conservation programs within the MokeWISE region, after accounting for those measures that are currently being implemented or are planned for implementation. While some of these programs in their current form are unfunded or underfunded, this analysis does not consider cost as a factor in expanding conservation programs. However, funding and monetary costs are recognized as a challenge.

To estimate the potential for water savings through conservation, first, the amount of water being conserved through implementation of ongoing and planned conservation BMPs was estimated. As previously described, water conservation and demand management projects which are already planned will be noted, as these projects will not create additional water available in the future for beneficial use.

Next, additional opportunities to maximize conservation were identified. BMPs not being implemented were reviewed and a basic feasibility determination was made based on cost-effectiveness and implementability considerations. The potential volume of conservation achievable through each non-implemented BMP was then estimated. Appendix B provides the methodology and assumptions for this analysis.

### **Existing and Future Conservation Measures**

UWMPs and AWMPs for water agencies and districts within the upper and lower Mokelumne River watershed (approximated as the MAC and ESJ regions) were reviewed to determine existing conservation measures already underway and planned for implementation in the future. Additionally, since EBMUD relies significantly on water resources in the Mokelumne watershed, its existing and planned conservation measures were also reviewed. The conservation measures being implemented or planned to be implemented by these

agencies and districts are described in the following sections. Additional BMP implementation levels are also identified and the savings associated with these expanded programs are calculated. The expanded 2040 implementation program assumes current levels (projected to 2040) are doubled and quadrupled; these savings are presented in a range. The theoretical maximum implementation level assumes that the gallons per capita per day (gpcd) for each agency is reduced to 85 gpcd, which assumes 55 gpcd for indoor use and 30 gpcd for outdoor use<sup>1</sup>.

Typically, the conservation measures implemented by urban suppliers, also referred to as BMPs or Demand Management Measures (DMMs) are described in UWMPs according to standards established by the California Urban Water Conservation Council (CUWCC). In September 2011, the CUWCC amended its *Memorandum of Understanding (MOU) Regarding Urban Water Conservation in California* (CUWCC 2011). The CUWCC signatory agencies first adopted the MOU in 1991 to expedite implementation of reasonable water conservation measures in urban areas by outlining fourteen BMPs that could be implemented to reduce long-term urban demands. A December 2008 amendment to the MOU restructured the fourteen BMPs into five BMP categories. Urban water suppliers typically use the original fourteen BMPs and associated numbers, consistent with the DWR UWMP Guidelines. Urban suppliers describe the fourteen BMPs and their compliance status in their UWMPs. The CUWCC MOU provides water savings assumptions for some of the BMPs which can be used to estimate potential water savings from implementation. Water savings assumptions from the CUWCC MOU are summarized in Table 10 and Table 11.

---

<sup>1</sup> According to the SWRCB, 55 gpcd is considered the performance standard for indoor use (SWRCB 2014c, 14). Research shows that more than half of Australia's residential water savings is a result of reduced outdoor water use. It is assumed that the maximum theoretical outdoor use that could be achieved in California would match that of Australia's, which is roughly 30 gpcd (Lund et. al 2011).

**Table 10: BMP Naming Changes in the CUWCC MOU and Water Savings Assumptions**

<b>Original BMP Number and Name</b>	<b>New BMP Category in the CUWCC MOU</b>	<b>Water Savings Assumption</b>
1. Water Survey Programs for Single-Family Residential and Multi-Family Residential Customers	Programmatic: Residential	Water savings assumptions will be based on the type and number of actions implemented.
2. Residential Plumbing Retrofit	Programmatic: Residential	Water savings assumptions will be based on the type and number of actions implemented.
3. System Water Audits, Leak Detection and Repair	Foundational: Utility Operations – Water Loss Control	To Be Determined
4. Metering with Commodity Rates for All New Connections and Retrofit of Existing Connections	Foundational: Utility Operations – Metering	Assume meter retrofits and volumetric rates combined will result in a 20% reduction in demand for retrofitted accounts.
5. Large Landscape Conservation Programs and Incentives	Programmatic: Landscape	Assume landscape BMP will result in a 15% to 20% reduction in demand for landscape irrigation by affected accounts.
6. High-Efficiency Clothes Washing Machine Financial Incentive Programs	Programmatic: Residential	Water savings assumptions will be based on the type and number of actions implemented.
7. Public Information Programs	Foundational: Education – Public Information Programs	Not Quantified
8. School Education Programs	Foundational: Education – School Education Programs	Not Quantified
9. Conservation Programs for Commercial, Industrial, and Institutional (CII) Accounts	Programmatic: Commercial, Industrial, and Institutional	See MOU Compliance Policy CII Water Savings Assumptions
10. Wholesale Agency Assistance Programs	Foundational: Utility Operations – Operations	Not Quantified
11. Retail Conservation Pricing	Foundational: Utility Operations – Pricing	Not Quantified



**Table 10: BMP Naming Changes in the CUWCC MOU and Water Savings Assumptions**

<b>Original BMP Number and Name</b>	<b>New BMP Category in the CUWCC MOU</b>	<b>Water Savings Assumption</b>
12. Conservation Coordinator	Foundational: Utility Operations – Operations	Not Quantified
13. Water Waste Prohibition	Foundational: Utility Operations – Operations	Not Quantified
14. Residential Ultra-Low-Flow Toilet (ULFT) Replacement Programs	Programmatic: Residential	Water savings assumptions will be based on the type and number of actions implemented.

Source: CUWCC 2011.

**Table 11: Commercial, Industrial, Institutional Water Savings Assumptions**

<b>Measure</b>	<b>Average Annual Savings (AFY)</b>	<b>Units</b>	<b>Measure Life (years)</b>
Hi-Efficiency Toilets	0.041748	Per toilet	25
Hi-Efficiency Urinals	0.069086	Per urinal	25
Ultra Low Volume Urinals	0.080603	Per urinal	25
Zero Consumption Urinals	0.0921146	Per urinal	25
Commercial High-Efficiency Single Load Clothes Washers	0.116618	Per clothes washer	10
Cooling Tower Conductivity Controllers	1.032250	Per cooling tower	5
Cooling Tower pH Controllers	3.981543	Per cooling tower	5
Connectionless Food Steamers	0.25	Per food steamer compartment	10
Medical Equipment Steam Sterilizers	1.538	Per steam sterilizer	20
Water-Efficient Ice Machines	0.834507	Per ice machine	10
Pressurized Water Brooms	0.1534	Per water broom	5
Dry Vacuum Pumps	0.64	Per vacuum pump	7

Source: CUWCC MOU Compliance Policies.

The Water Conservation Act of 2009 (SBx7-7, or 20x2020), which was passed in 2009, requires an evaluation of baseline per capita water use and identification of interim and 2020 per capita water use targets to achieve a 20% per capita water use reduction by 2020. Only water conservation and recycled water can be used to achieve the 2015 and 2020 targeted demand reductions. The Act modified Division 6 of the California Water Code (CWC) which also requires agricultural water suppliers delivering water to 2,000 or more irrigated acres (excluding recycled water) to prepare AWMPs and implement efficient water management practices (EWMPs). Specific EWMPs that must be implemented include:

- Measure the volume of water delivered to customers
- Adopt a pricing structure for customers based at least in part on quantity delivered.

### Conservation in the Upper Watershed

The primary water purveyors in the upper watershed are AWA, CCWD, Calaveras Public Utility District (CPUD), and JVID. 20x2020 per capita water use targets for AWA and CCWD are 166 gallons and 172 gallons, respectively (AWA 2011, 3-15; CCWD 2011, 3-10). These are higher than established targets for other parts of California.

#### *Amador Water Agency*

As shown in Table 12, it is estimated that AWA saved 4.8 AFY in 2010 through implementing the quantified BMPs. Assuming 2010 implementation levels in 2040, AWA could save 17.0 AFY in 2040. If current implementation levels were doubled, AWA could potentially save 61.8 AFY in 2040; if current levels were quadrupled, AWA could potentially save 14.1 AFY in 2040. Thus, AWA could potentially save between 44.9 AFY and 97.2 AFY in 2040 under an expanded conservation program.

Gallons per capita per day (gpcd) in the AWA service area is projected to be 166 gpcd in 2020, as a result of 20% by 2020 requirements. If gpcd were reduced to 85 gpcd in 2040, AWA could potentially save 4,030.7 AFY<sup>2</sup>. Methodology and assumptions for calculating these numbers are presented in Appendix B.

---

<sup>2</sup> This gpcd number is presented to provide a theoretical maximum of estimated conservation savings. It is understood that to achieve 85 gpcd, significant funding and public outreach and education would be needed.

**Table 12: AWA Estimated Future Savings Potential Associated with Conservation BMPs**

Conservation Scenario*	BMP Number														Total
	1	2	3	4	5	6	7	8	9	10	11	12	13	14	
<b>Amount Conserved in 2010 based on UWMP (AFY)</b>	3.9	0	NQ	NQ	0	0	NQ	NQ	0	NQ	NQ	NQ	NQ	0.9	4.8
<b>Amount Conserved in 2040 if BMP Maintained at Current (2010) Implementation Level (AFY)</b>	6.7	9.4	NQ	NQ	0.0	0.0	NQ	NQ	0.0	NQ	NQ	NQ	NQ	0.9	17.0
<b>Amount Conserved in 2040 (Expanded BMP) (AFY)</b>	13.3 – 26.7	9.4	NQ	NQ	11.7 – 23.4	13.8 – 27.5	NQ	NQ	10.4 – 20.8	NQ	NQ	NQ	NQ	3.2 – 6.4	61.8 – 114.1
<b>Additional Conservation Anticipated under Expanded 2040 Program**</b>	6.7 – 20.0	0.0	NQ	NQ	11.7	13.8 – 27.5	NQ	NQ	10.4 – 20.8	NQ	NQ	NQ	NQ	2.3 – 5.5	44.9 – 97.2
<b>Additional Conservation Anticipated under Maximum Theoretical 2040 Program***</b>	--	--	--	--	--	--	--	--	--	--	--	--	--	--	4,030.7

\* NQ = not quantified

\*\* Calculates the difference between the estimated future savings in 2040 at expanded levels of conservation and the estimated future savings in 2040 at current levels of conservation.

\*\*\* Calculated based on assumed 85 gpcd compared to 166 gpcd (2020 estimated gpcd). It is understood that to achieve 85 gpcd, significant amounts of grant funding and extensive public education would be required.

### *Calaveras County Water District*

As shown in Table 13, it is estimated that CCWD saved 0 AFY in 2010 through implementing the quantified BMPs. Because CCWD submitted exemption reports and is not currently implementing any conservation measures, if 2010 implementation levels are assumed in 2040, CCWD is estimated to save 0 AFY in 2040. If conservation programs are expanded to what CCWD indicates in their exemption reports, CCWD could potentially save 1,385 AFY in 2040. If CCWD doubles the implementation of this expanded program, CCWD could save 1,485.4 AFY<sup>3</sup>. Thus, CCWD could potentially save between 1,385 AFY and 1,485.4 AFY in 2040 under an expanded conservation program. While it is anticipated that some of these savings will be attributed to meeting requirements for future water use reductions, additional conservation savings are likely to contribute to available water for the MokeWISE program.

CCWD plans to reduce its per capita water use from its current rate of 217 gpcd to 172 gpcd by 2020. This translates to an annual savings of 268 AFY. For the purposes of this study, it is assumed that this will all be met through implementation of future conservation measures. If gpcd were reduced to 85 gpcd in 2040, CCWD could potentially save 5,106.9 AFY<sup>4</sup>. Methodology and assumptions for calculating these numbers are presented in Appendix B.

---

<sup>3</sup> This figure is not quadruple the double expanded program as BMP 14 is expected to be fully implemented after the double expansion.

<sup>4</sup> This gpcd number is presented to provide a theoretical maximum of estimated conservation savings. It is understood that to achieve 85 gpcd, significant funding and public outreach and education would be needed.

**Table 13: CCWD Estimated Future Savings Potential Associated with Conservation BMPs**

Conservation Scenario*	BMP Number														Total
	1	2	3	4	5	6	7	8	9	10	11	12	13	14	
<b>Amount Conserved in 2010 based on UWMP (AFY)</b>	0.0	0.0	NQ	NQ	0.0	0.0	NQ	NQ	0.0	NQ	NQ	NQ	NQ	0.0	<b>0.0</b>
<b>Amount Conserved in 2040 if BMP Maintained at Current (2010) Implementation Level (AFY)</b>	0.0	0.0	NQ	NQ	0.0	0.0	NQ	NQ	0.0	NQ	NQ	NQ	NQ	0.0	<b>0.0</b>
<b>Amount Conserved in 2040 (Expanded BMP) (AFY)</b>	30.3 – 60.4	63.6 – 126.6	NQ	NQ	2.8 – 5.3	3.3 – 6.5	NQ	NQ	1.3 – 2.9	NQ	NQ	NQ	NQ	1,283.7	<b>1,385.0 – 1,485.4</b>
<b>Additional Conservation Anticipated under Expanded 2040 Program**</b>	30.3 – 60.4	63.6 – 126.6	NQ	NQ	2.8 – 5.3	3.3 – 6.5	NQ	NQ	1.3 – 2.9	NQ	NQ	NQ	NQ	1,283.7	<b>1,385.0 – 1,485.4</b>
<b>Additional Conservation Anticipated under Maximum Theoretical 2040 Program***</b>	--	--	--	--	--	--	--	--	--	--	--	--	--	--	<b>5,106.9</b>

\* NQ = not quantified

\*\* Calculates the difference between the estimated future savings in 2040 at expanded levels of conservation and the estimated future savings in 2040 at current levels of conservation.

\*\*\* Calculated based on assumed 85 gpcd compared to 172 gpcd (2020 estimated gpcd). It is understood that to achieve 85 gpcd, significant amounts of grant funding and extensive public education would be required.

### *Calaveras Public Utility District*

CPUD serves Mokelumne Hill, San Andreas, and outlying areas. In 2013, CPUD supplied approximately 1,120 AFY to its customers (CPUD 2014a). Because CPUD supplies less than 3,000 AFY and has less than 3,000 customers it is not required to prepare an UWMP or develop 20x2020 water use targets. Due to the ongoing drought, in July 2014, CPUD adopted an ordinance to establish a water conservation plan to reduce water consumption through conservation. The ordinance includes a prohibition against waste that will always be in effect, regardless of a drought or water supply shortages. The water waste prohibition includes no excessive water flow or runoff, customer obligation to fix leaks and breaks, recirculating water requirement for decorative water fountains, limits on washing vehicles, recirculating water at commercial car washes, and other restrictions and requirements. The ordinance also outlines conservation requirements during increasingly severe stages of drought.

Information on existing conservation program success and potential for future programs is not currently available. While estimating the potential savings achieved through addressing leaking infrastructure is theoretically possible, CPUD does not currently have information about the potential system losses so these savings cannot be calculated at this time (CPUD 2014b). However, because CPUD's water use is a relatively small percentage of the MokeWISE Region demand, supply from potential future conservation within the CPUD service area was considered to be negligible compared to other potential future supplies.

CPUD had 1,898 connections in its service area in 2008. The District's Water System Master Plan assumes an annual growth rate of 2%, compounded annual through 2030 (CPUD 2008, 13). Assuming this annual growth rate continues through 2040, the total number of connections in 2040 is projected to be 3,577. In 2014, CPUD projected 2,137 connections in its service area. The CPUD service area population is roughly 5,000, which calculates to roughly 2.3 people per connection. Assuming this people per connection in 2040, the population of the CPUD service area is calculated to be 8,367. As stated above, water use is 1,120 AFY. Assuming a current population of 5,000, this is equivalent of 200 gpcd. If 200 gpcd is assumed in 2040, CPUD will use 1,874.2 AFY in 2040. If CPUD reduced its gpcd to 85 gpcd in 2040, it would use 797.2 AFY in 2040. This results in a savings of 1,077.1 AFY in 2040.

### *Jackson Valley Irrigation District*

JVID provides irrigation water to farms and ranches in Jackson Valley, as well as homes, mobile home parks, and a biomass energy plant which opened in 2012. The 2008 Municipal Service Review (MSR) for Amador County states that JVID's surface water use averages 2 acre-feet per year (note that this does not include the biomass energy plant, which contracts with JVID for approximately 400 AFY) (JVID 2014 personal communication). JVID has implemented the following measures in response to the drought:

- Started a water allotment to farmers, which was based on the amount of water individual crops needs and the amount of land irrigated. Due to this allotment, some farming practices were reduced by 50 percent.
- Doubled existing water rate to balance budget because lack of expected water sales.
- Implemented water conservation on smaller residential users.
- Installed meters and created a program within a 2 month time period for 60 users.

Most recently, the JVID Board of Directors established a Drought Committee which meets twice monthly to address drought impacts and water conservation efforts. The JVID Board created and adopted its Water Shortage/Drought Policy and encourages water conservation in its service area through the distribution of public education materials regarding both the drought and ways to save water. JVID has instituted a water allotment system as shown in the JVID Decision Tree for Water Allocation and Billing. All agricultural water users that irrigate an acre of land or more are being required to install water meters to monitor water use. Smart irrigation scheduling and shifting from flood and spray irrigation to drip irrigation can result in significant savings; savings associated with both of these agricultural BMPs are quantified in the agricultural conservation and efficiency section below.

To encourage water use efficiency, JVID has also doubled the irrigation water rate from \$12/AF to \$24/AF. Significant water savings are being achieved. Historically, average crop irrigation in May is approximately 2,000 AF, but in May 2014 water use for crop irrigation was 600 AF. In 2013 JVID delivered 16,000 AF to users; this year JVID staff estimates demands will be closer to 8,500 AF due to increases in water rates and implementation of water allotments. In order to implement a water metering program and a conservation project, the Amador County Board of Supervisors approved a loan request of \$180,000 from JVID, which will help them further conserve water in response to the ongoing drought.

JVID's distribution system includes a canal (Jackson Creek) and a pipeline system, with 50 percent of the District's water traveling through the canal system and 50 percent traveling through the pipeline system. There is currently a 20 percent loss associated with the canal system; however, because Jackson Creek serves as the canal, no lining or other efficiencies can be installed to decrease losses (JVID 2014 personal communication). JVID has reduced pipeline distribution losses from 25 percent to roughly 10 percent, due to recent valve replacements and other efficiency measures (JVID 2014 personal communication). Assuming JVID will deliver roughly 8,500 AFY in the future and pipeline losses were decreased to 5 percent, the District could potentially conserve 212.5 AFY.

### Conservation in the Lower Watershed

Urban water suppliers in the lower watershed include the Cities of Lodi, Stockton, Manteca, Ripon, and Lathrop, Escalon, Stockton East Water District (SEWD), and California Water Service Company. Agricultural water suppliers include Central Delta Water Agency, North

San Joaquin Water Conservation District (NSJWCD), WID, SEWD, Central San Joaquin Water Conservation District, Oakdale Irrigation District, and South San Joaquin Irrigation District. Only the suppliers that rely on Mokelumne River as a water supply source are included in this evaluation. These include the City of Lodi, City of Stockton, NSJWCD, and WID (see Table 14).

**Table 14: Primary Water Supply Sources in the Lower Watershed**

<b>Supplier</b>	<b>Primary Surface Supply Source(s)</b>
<b><i>City of Stockton</i></b>	<b><i>San Joaquin River, Mokelumne River</i></b>
<b><i>City of Lodi</i></b>	<b><i>Mokelumne River</i></b>
City of Tracy	Stanislaus River, Delta
City of Manteca	Stanislaus River
City of Ripon	None (all groundwater)
City of Lathrop	Stanislaus River
City of Escalon	Stanislaus River
Stockton East Water District	Calaveras River, Stanislaus River
California Water Service Company	Calaveras River, Stanislaus River
Central Delta Water Agency	Delta
<b><i>North San Joaquin Water Conservation District</i></b>	<b><i>Mokelumne River</i></b>
<b><i>Woodbridge Irrigation District</i></b>	<b><i>Mokelumne River</i></b>
Central San Joaquin Water Conservation District	Stanislaus River
Oakdale Irrigation District	Stanislaus River
South San Joaquin Irrigation District	Stanislaus River



### *City of Stockton*

Based on a combination of the City of Stockton water savings assumptions and CCWD's water savings assumptions, it is estimated that the City of Stockton saved 321.4 AFY in 2010 through implementing the quantified BMPs (Table 15). Assuming 2010 implementation levels in 2040, the City is estimated to save 495.9 AFY in 2040. If implementation levels were doubled in 2040, Stockton could potentially save 1,083.6 AFY in 2040; if implementation levels were quadrupled, Stockton could potentially save 2,167.2 AFY. Thus, the City could potentially save between 587.7 AFY and 1,671.3 AFY under an expanded conservation program. While it is anticipated that some of these savings will be attributed to meeting requirements for future water use reductions, additional conservation savings are likely to contribute to available water for the MokeWISE program.

The City plans to reduce its per capita water use from its current rate of 195 gpcd to 165 gpcd by 2020, which is higher than some other portions of California. This translates to a savings of 170 AFY<sup>5</sup>. This reduction will be achieved through a combination of conservation and recycled water. For the purposes of this study, it is assumed that this will all be met through implementation of future conservation measures. If gpcd were reduced to 85 gpcd in 2040, Stockton could potentially save 23,508.2 AFY<sup>6</sup>. Methodology and assumptions for calculating these numbers are presented in Appendix B.

---

<sup>5</sup> This figure was calculated by multiplying the current gpcd by the population of Stockton in 2010 and the future gpcd by the population in 2020 to get the total gallons per day in 2010 and 2020. These numbers were converted to AFY and the difference between the two numbers, 170 AFY, is the calculated savings between 2010 and 2020.

<sup>6</sup> This gpcd number is presented to provide a theoretical maximum of estimated conservation savings. It is understood that to achieve 85 gpcd, significant funding and public outreach and education would be needed.

**Table 15: City of Stockton Estimated Future Savings Potential Associated with Conservation BMPs**

Conservation Scenario*	BMP Number														Total
	1	2	3	4	5	6	7	8	9	10	11	12	13	14	
<b>Amount Conserved in 2010 based on UWMP (AFY)</b>	0.0	25.0	NQ	NQ	0.0	24.5	NQ	NQ	252.9	NQ	NQ	NQ	NQ	19.0	<b>321.4</b>
<b>Amount Conserved in 2040 if BMP Maintained at Current (2010) Implementation Level (AFY)</b>	0.0	38.6	NQ	NQ	0.0	37.8	NQ	NQ	390.1	NQ	NQ	NQ	NQ	29.4	<b>495.9</b>
<b>Amount Conserved in 2040 (Expanded BMP) (AFY)</b>	54.2 – 108.4	77.1 – 154.2	NQ	NQ	5.3 – 10.2	83.5 – 167.4	NQ	NQ	780.2 – 1,560.4	NQ	NQ	NQ	NQ	83.3 – 166.6	<b>1,083.6 – 2,167.2</b>
<b>Additional Conservation Anticipated under Expanded 2040 Program**</b>	54.2 – 108.4	38.5 – 115.6	NQ	NQ	5.3 – 10.2	45.7 – 129.6	NQ	NQ	390.1 – 1,170.3	NQ	NQ	NQ	NQ	53.9 – 137.2	<b>587.7 – 1,671.3</b>
<b>Additional Conservation Anticipated under Maximum Theoretical 2040 Program***</b>	--	--	--	--	--	--	--	--	--	--	--	--	--	--	<b>23,508.2</b>

\* NQ = not quantified

\*\* Calculates the difference between the estimated future savings in 2040 at expanded levels of conservation and the estimated future savings in 2040 at current levels of conservation.

\*\*\* Calculated based on assumed 85 gpcd compared to 165 gpcd (2020 estimated gpcd). It is understood that to achieve 85 gpcd, significant amounts of grant funding and extensive public education would be required.

### *City of Lodi*

As shown in Table 16, it is estimated that the City of Lodi did not achieve any water savings in 2010 through implementation of the quantified BMPs. Assuming 2010 implementation levels in 2040, the City is estimated to save 730.1 AFY in 2040<sup>7</sup>. If implementation levels doubled in 2040, the City of Lodi could potentially save 1,031.7 AFY in 2040; if implementation levels were quadrupled, the City could potentially save 1,333.6 AFY<sup>8</sup>. Thus, Lodi could potentially save between 301.6 AFY and 603.5 AFY under an expanded conservation program. While it is anticipated that some of these savings will be attributed to meeting requirements for future water use reductions, additional conservation savings are likely to contribute to available water for the MokeWISE program.

The City plans to reduce its per capita water use from its current rate of 248 gpcd to 199 gpcd by 2020, which is higher than some other portions of California. This translates to a savings of 2,006 AFY<sup>9</sup>. This reduction will be achieved through a combination of conservation and recycled water. For the purposes of this study, it is assumed that this will all be met through implementation of future conservation measures. If gpcd were reduced to 85 gpcd in 2040, Lodi could potentially save 10,945.0 AFY<sup>10</sup>. Methodology and assumptions for calculating these numbers are presented in Appendix B.

---

<sup>7</sup> This is due to a currently planned BMP which was not implemented in 2010, but will be fully implemented by 2040.

<sup>8</sup> These figures are not double and quadruple the current conservation savings as some of the BMPs are expected to be fully implemented prior to expansion.

<sup>9</sup> This figure was calculated by multiplying the current gpcd by the population of Lodi in 2010 and the future gpcd by the population in 2020 to get the total gallons per day in 2010 and 2020. These numbers were converted to AFY and the difference between the two numbers, 2,006 AFY, is the calculated savings between 2010 and 2020.

<sup>10</sup> This gpcd number is presented to provide a theoretical maximum of estimated conservation savings. It is understood that to achieve 85 gpcd, significant funding and public outreach and education would be needed.

**Table 16: City of Lodi Estimated Future Savings Potential Associated with Conservation BMPs**

Conservation Scenario*	BMP Number														Total
	1	2	3	4	5	6	7	8	9	10	11	12	13	14	
<b>Amount Conserved in 2010 based on UWMP (AFY)</b>	0.0	0.0	NQ	0.0	0.0	0.0	NQ	NQ	0.0	NQ	NQ	NQ	NQ	0.0	<b>0.0</b>
<b>Amount Conserved in 2040 if BMP Maintained at Current (2010) Implementation Level (AFY)</b>	0.0	0.0	NQ	730.1	0.0	0.0	NQ	NQ	0.0	NQ	NQ	NQ	NQ	0.0	<b>730.1</b>
<b>Amount Conserved in 2040 (Expanded BMP) (AFY)</b>	9.6 – 19.3	13.9 – 27.8	NQ	730.1	2.4 – 4.8	4.7 – 0.4	NQ	NQ	262.2 – 524.5	NQ	NQ	NQ	NQ	8.8 – 17.7	<b>1,031.7 – 1,333.6</b>
<b>Additional Conservation Anticipated under Expanded 2040 Program**</b>	9.6 – 19.3	13.9 – 27.8	NQ	0.0	2.4 – 4.8	4.7 – 0.4	NQ	NQ	262.2 – 524.5	NQ	NQ	NQ	NQ	8.8 – 17.7	<b>301.6 – 603.5</b>
<b>Additional Conservation Anticipated under Maximum Theoretical 2040 Program***</b>	--	--	--	--	--	--	--	--	--	--	--	--	--	--	<b>10,945.0</b>

\* NQ = not quantified

\*\* Calculates the difference between the estimated future savings in 2040 at expanded levels of conservation and the estimated future savings in 2040 at current levels of conservation.

\*\*\* Calculated based on assumed 85 gpcd compared to 199 gpcd (2020 estimated gpcd). It is understood that to achieve 85 gpcd, significant amounts of grant funding and extensive public education would be required.

### *Woodbridge Irrigation District*

WID currently implements the latest in agricultural conservation practices. Additional water use savings may be achievable through enhanced conservation programming and incentives. Because detailed information on individual customer water use patterns is not available, potential savings could not be quantified. Savings associated with agricultural efficiencies within the WID service area are captured in the Agricultural Conservation and Efficiency section below. Additional information on WID is presented in Appendix B.

### *North San Joaquin Water Conservation District*

NSJWCD currently does not implement agricultural conservation practices. Additional water use savings may be achievable through implementation of conservation programming and incentives. However, because information on individual customer water use patterns is not available, potential savings could not be quantified. Savings associated with agricultural efficiencies within the NSJWCD service area are captured in the Agricultural Conservation and Efficiency section below. Additional information on NSJWCD is presented in Appendix B.

### *Agricultural Conservation and Efficiency*

A report published in 2008 by the Pacific Institute studied the effects of four scenarios for increasing agricultural water use efficiency (Cooley, et al. 2008). The four scenarios evaluated were:

- Modest crop shifting – shift 25 percent of irrigated field crop acreage to irrigated vegetable crop acreage
- Smart irrigation scheduling – use irrigation scheduling information to help farmers more precisely irrigate to meet crop water needs and boost production
- Advanced irrigation management – apply regulated deficit irrigation to almonds, pistachios, citrus trees, and vines during stress-tolerant growth stages
- Efficient irrigation technology – shift a fraction of the crops irrigated using flood irrigation to sprinkler and drip systems

Water use under each of these four scenarios was compared against baseline agricultural water use for the Sacramento River, San Joaquin River, and Tulare Lake hydrologic regions to achieve a percent reduction in agricultural water use. Results for the San Joaquin River hydrologic region indicate that modest crop shifting could result in a 3 percent decrease in agricultural water use, smart irrigation scheduling could yield a 13 percent reduction in agricultural water use, advanced irrigation management could generate a 6 percent decrease in agricultural water use, and efficient irrigation technology could result in a 3 percent reduction in agricultural water use.

The San Joaquin IRWMP estimated that the ESJ Region used approximately 1,070,017 AFY for agricultural irrigation in 2005, which is projected to decrease to 911,072 AFY by 2030 (GBA

2007). As shown in Table 17, if the percent savings for each of the four scenarios are applied to ESJ Region’s estimated agricultural water use in 2005 and 2030, the following savings may be achieved.

**Table 17: Potential Agricultural Water Savings from Four BMPs**

<b>BMP Scenario</b>	<b>2005 Savings (AFY)</b>	<b>2030 Savings (AFY)</b>
<b>Modest Crop Shifting</b>	32,101	27,332
<b>Smart Irrigation Scheduling</b>	139,102	118,439
<b>Advanced Irrigation Management</b>	64,201	54,664
<b>Efficient Irrigation Technology</b>	32,101	27,332
<b>TOTAL</b>	<b>267,504</b>	<b>227,768</b>

The potential savings associated with each of these strategies assumes that there has been no prior implementation. Because water saving strategies are already being implemented in parts of the San Joaquin Valley, the actual savings that could be achieved is likely lower. If 25 percent% of farmers have already implemented the conservation strategies, then 170,826 AFY of savings could potentially be generated in 2030.

*Conservation in the EBMUD Service Area*

EBMUD is an original signatory of the CUWCC MOU and maintains compliance with the MOU. EBMUD implements all fourteen BMPs, as well as additional conservation measures not included in the CUWCC MOU. EBMUD has self-certified that its water conservation achievements are on-track, ahead of schedule or have reached 100 percent completion for all established BMP, Flex Trak, or gpcd coverage requirements. It plans to continue to implement conservation measures to meet its water conservation goals, provide a reliable water supply, and help meet its future water use reduction targets. EBMUD adopted a Water Conservation Master Plan (WCMP) in 1994 addressing both supply-side (water supplier) and demand-side (customer) measures. In 2011 EBMUD updated its WCMP to meet long-term water conservation planning goals to 2040. The WCMP presents a phased implementation of measures based on water production and customer demands to achieve a cumulative water savings of 62 MGD by 2040. Approximately 100 conservation measures were considered for implementation and 53 were selected. Since adoption of the WCMP in 1994, EBMUD has achieved a water savings of 26 MGD through 2010.

Because EBMUD is currently fully implementing and/or exceeding CUWCC targets for all BMPs, it has been assumed that no additional water conservation potential is available in the EBMUD service area.

EBMUD plans to reduce its per capita water use from its current rate of 175 gpcd to 151 gpcd by 2020. This translates to an annual savings of 2,534 AFY. This reduction will be achieved through a combination of conservation and recycled water. For the purposes of this study, it is assumed that this will all be met through implementation of future conservation measures. If EBMUD reduced its gpcd to 85 gpcd in 2040, it could potentially save 135,263.0 AFY in 2040<sup>11</sup>.

## Summary of Potential Conservation Savings

Table 18 provides a summary of the future potential water savings.

**Table 18: Potential Additional Future Supply Available through Expanded Conservation Programs\***

<b>Agency</b>	<b>Total Savings Achievable (AFY) under Expanded Program</b>	<b>Total Savings Achievable (AFY) under Theoretical Maximum (85 gpcd)</b>
AWA	44.9 – 97.2	4,030.7
CCWD	1,385.0 – 1,485.4	5,106.9
CPUD	Not quantified	1,077.1
JVID	212.5	Not quantified
City of Stockton	587.7 – 1,671.3	23,508.2
City of Lodi	301.6 – 603.5	10,945.0
WID	Not quantified	Not quantified
NSJWCD	Not quantified	Not quantified
EBMUD	--	135,263.0
<b>Agricultural</b>	170,826	170,826.0**
<b>Total</b>	<b>173,357.7 – 174,895.9</b>	<b>350,756.9</b>

\* The numbers presented reflect expanded implementation of the BMPs discussed earlier in the section. They do not include BMPs that could not be quantified due to limited available data.

\*\* This figure does not reflect 85 gpcd. It is assumed here that this agricultural program would be implemented in both the expanded program scenario and the theoretical maximum program scenario.

<sup>11</sup> Assuming 151 gpcd in 2040, EBMUD would use 309,403.6 AFY in 2040, with an estimated 2040 population of 1,828,044. If EBMUD were to achieve 85 gpcd in 2040, it would use 174,167.6 AFY in 2040, resulting in a savings of 135,263.0 AFY. It is understood that to achieve 85 gpcd, significant funding and public outreach and education would be needed.

## Challenges with Maximizing Conservation

Challenges associated with maximizing conservation as a supply in the MokeWISE program are listed below. These challenges should be considered when discussing conservation projects in the MokeWISE program.

- **Downstream impacts.** Indoor conservation, while decreasing the demand on supplies, can also decrease the amount of water being discharged from wastewater treatment plants. As a result, indoor conservation can potentially impact downstream users. When discussing indoor conservation programs within the MokeWISE process, this challenge should be considered.
- **Growth impacts.** Increased conservation may not necessarily decrease the demand on supplies, but rather reduce the need for additional supplies to meet growth. For example, southern California water utilities have seen that water saved from conservation activities merely postpones the need to import additional water instead of decreasing demand on supplies. Furthermore, agricultural areas may develop extensive and expensive water use efficiency measures to increase crop production. However, these investments may not necessarily reduce water use if additional acreage is planted.
- **Economic feasibility.** Conservation projects and programs can be costly, potentially limiting the ability of agencies implement projects and support ongoing overhead costs. While there are funding opportunities available to help offset start-up costs, agencies may reach a point of diminishing returns on conservation programs. For example, the marginal cost of replacing the last few toilets may be significant and may not be economically feasible. While this point of diminishing returns may change over time as technology advances, some of the conservation theoretically available for MokeWISE may not be economically feasible.

## Opportunities for Maximizing Conservation

The following are potential opportunities for maximizing conservation. These examples can be considered when discussing potential MokeWISE projects and programs.

- **Further implementation of BMPs.** Enhanced implementation of conservation BMPs beyond current levels could result in substantially higher levels of savings, provided sufficient funding is available. Reducing water use could potentially free up Mokelumne River supplies for alternative uses.
- **Implementation of additional BMPs.** Additional savings could be achieved by implementing additional BMPs that are not quantified in this study. For instance, water neutral development requirements may increase conservation levels by shifting cost of conservation programs to new developments and away from ratepayers.



- **Infrastructure improvements.** Losses associated with the conveyance of water supplies can be significant depending on the type of conveyance and the amount of water being conveyed. Leak detection programs can be implemented to improve efficiency in pipeline systems and pipelines can be installed to reduce losses associated with open canals. For systems conveying water in streams, shade trees can be planted which could help reduce evaporative losses.
- **Altering rate structures.** Raising water rates could encourage more efficient water use. Potential rate structures may include seasonal, block, time of use, surcharges, or use of water budgets.

## Desalination

While the upper and lower watersheds are not near the ocean, allowing for typical desalination opportunities, demineralization of high salinity groundwater or exchange opportunities from coastal desalination efforts may provide potential supply options. Groundwater demineralization (which uses desalination plant technology to decrease salinity in groundwater supplies) was assessed for feasibility within the watershed. Additionally, a regional desalination project has been initiated in the Bay Area, which may present an opportunity for collaboration and potential water supply through exchange.

In order to assess potential desalinated supplies for the MokeWISE program, the following methodology was applied:

- Identify potential groundwater demineralization opportunities.
- Assess potential exchange opportunities for desalinated water from the Bay Area Regional Desalination Project.
- Quantify potential supplies from groundwater demineralization and desalination by analyzing other demineralization projects in California and reviewing Bay Area Regional Desalination Project reports to estimate potential for exchange.

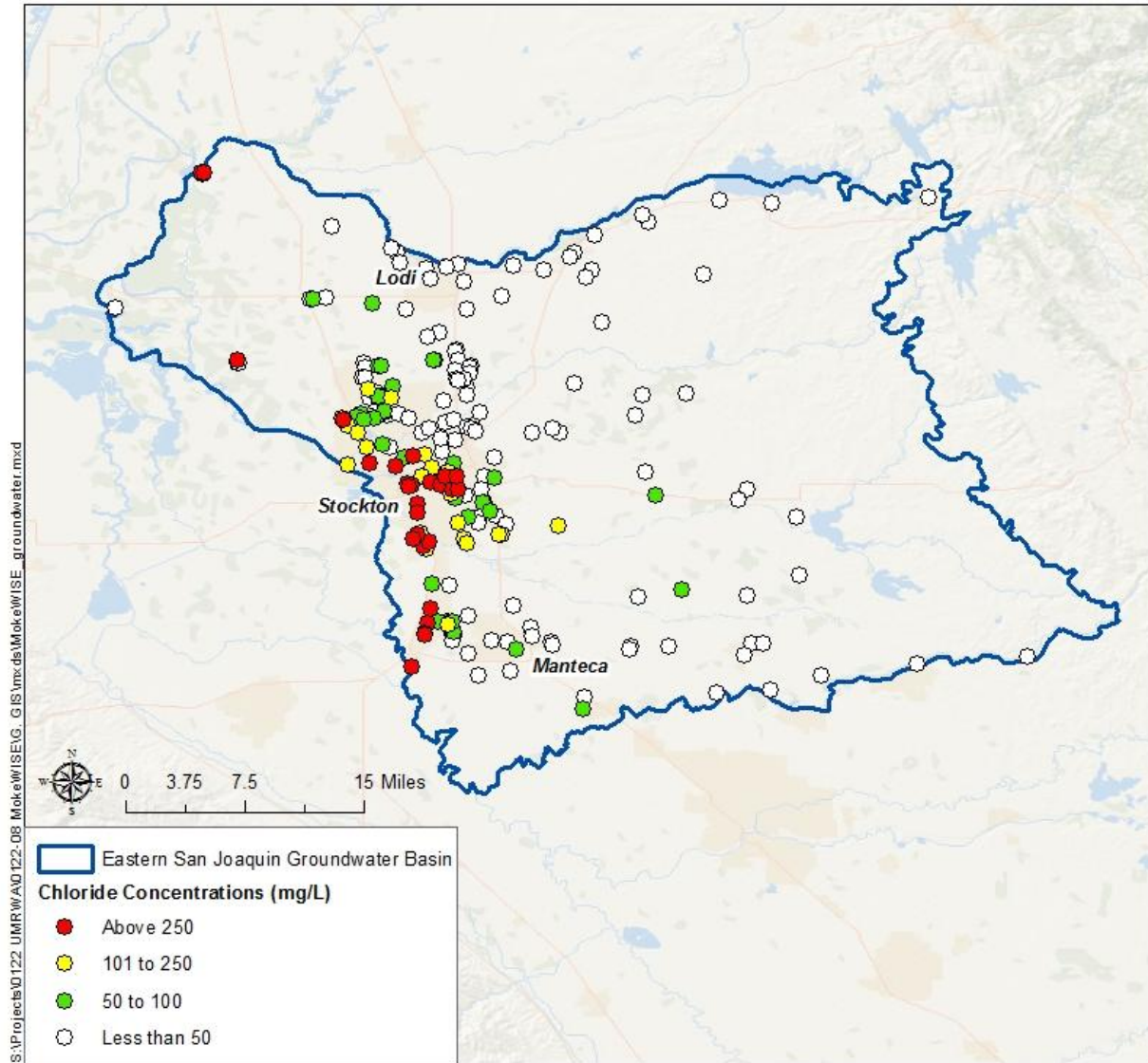
As discussed in the Groundwater section, groundwater is limited within the upper watershed; therefore, the analysis of potential groundwater demineralization opportunities focused on potential groundwater demineralization opportunities in the lower watershed. The San Joaquin Valley Groundwater Basin, which underlies portions of the upper and the lower watershed, includes multiple subbasins as shown in Figure 1.

As detailed in the Groundwater section, the Eastern San Joaquin Groundwater Subbasin is “critically overdrafted,” indicating the rate of groundwater pumping exceeds the rate of recharge. Groundwater level declines have resulted in steep gradients from the Delta, causing intrusion of highly saline groundwater. Salt intrusion in the groundwater basin results in water quality impacts that render the supply unusable for meeting drinking water needs and for irrigating crops. Municipal supply wells in the City of Stockton and irrigation wells in the areas surrounding the City have been abandoned due to elevated salt levels.

In 2003, USGS, the GBA, and DWR undertook a 5-year, \$2.7 million study of saline intrusion in Eastern San Joaquin County. The purpose of the study was to quantify the source, extent, and vertical distribution of high-chloride groundwater. USGS compiled an extensive groundwater level and water quality Geographic Information Systems (GIS) database consisting of more than 4,000 wells throughout the lower watershed.

Figure 12 shows the chloride concentrations of wells in the Eastern San Joaquin Subbasin based on historic data from 1984 to 2004. The red dots indicate wells with chloride concentrations greater than 250 mg/L, the U.S. Environmental Protection Agency (EPA) Secondary Maximum Contaminant Level (SMCL) for chloride. Some of these wells have been removed from service.

**Figure 12: Chloride Concentrations of Wells in the Eastern San Joaquin Subbasin (1984 to 2004)**

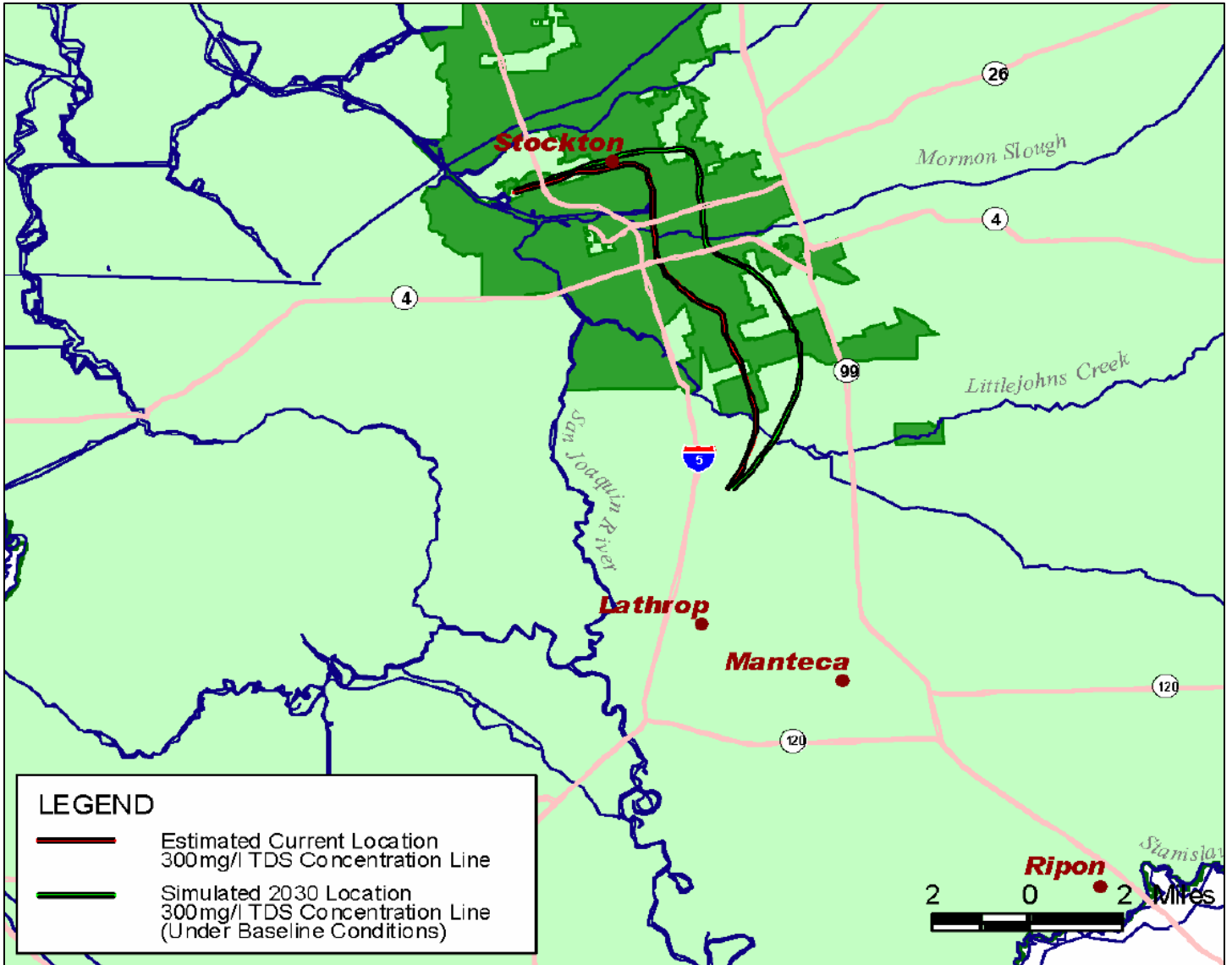


Source: 2007 ESJ IRWMP, Page 4-56 (GBA, 2007).

At chloride concentrations of 300 mg/L, water becomes unsuitable for most uses. The 300 mg/L isochlor, as measured in 2000 and described in the ESJ IRWMP, is shown in Figure 13. Also shown is the estimated 300 mg/L isochlor in 2030 if no actions are taken to remediate the basin are taken. As shown, chloride concentrations exceeding 300 mg/L extend eastward almost to Highway 99 in southwestern Stockton. Projections indicate that the rate of eastward migration of the saline front is approximately 150 to 250 feet per year. Results of this study indicate several sources of saline water including surface water infiltration, dissolution of salts near the Delta margin, contributions from underlying deposits, and possible irrigation return flow. The study also concluded that, despite increased precipitation in the 2005-2006 winter, the saline front underlying the City of Stockton has encroached further eastward and the groundwater basin underlying the City experienced water quality degradation. Preliminary results showed that water from wells near the San Joaquin River Delta had chloride concentrations as high as 1,800 mg/L (GBA 2007).

It is assumed that groundwater found in the locations shown in Figure 12 and Figure 13 with chloride concentrations exceeding 300 mg/L result in groundwater that is unsuitable for potable uses. This supply could be treated with reverse osmosis (RO) at a demineralization plant to reduce salinity and make the supply useable for potable and/or irrigation purposes. The RO treatment process results in a treated water effluent with lower TDS that can be used for agricultural and urban water uses or blended with other water supplies for use. Reverse osmosis generates a brine stream that must be disposed of, presenting a significant constraint, particularly for inland applications. Pumping and treating saline groundwater could increase the rate of localized saline intrusion. Additionally, because the Eastern San Joaquin Groundwater Basin is already in a state of overdraft and is experiencing saline intrusion, enabling groundwater that is not currently useable to be pumped and used for irrigation and domestic purposes could result in a net increase in groundwater withdrawals, exacerbating these issues.

Figure 13: Estimated 2000 and Projected 2030 Saline Front



Source: 2007 ESJ IRWMP, Figure 4-38 (GBA, 2007).

## Regional Desalination Partnerships

Five Bay Area water agencies, Contra Costa Water District, EBMUD, San Francisco Public Utilities Commission (SFPUC), Santa Clara Valley Water District (SCVWD), and Zone 7 Water Agency (Zone 7) are jointly exploring the development of regional desalination facilities that could benefit the 5.4 million Bay Area residents and businesses served by these agencies. The concept for the Bay Area Regional Desalination Project (BARDP) has changed over time since it was initially conceptualized in 2003. Initially, a 120 MGD plant was conceptualized to help the agencies during major facilities outages and emergencies. The concept has evolved to a 10 to 20 MGD plant in eastern Contra Costa County to treat brackish water, creating a drought-proof drinking water supply for the agencies.

In 2003, Contra Costa Water District, EBMUD, and SCVWD entered into an MOU to explore the initial viability of the BARDP through completion of a pre-feasibility analysis. The pre-feasibility analysis evaluated permit requirements and desalinated water quality, and included a siting study. This analysis ultimately concluded that a regional desalination facility in the Bay Area may be feasible. In 2007, the BARDP Feasibility Study was completed, in which the agencies revisited their respective needs for desalinated water. The 2007 Feasibility Study also identified three potential locations for the facility and developed preliminary design for two potential desalination plant configurations (a 20 MGD seawater RO plant and a 65 MGD brackish water RO plant) (URS 2007, ES-6). Desalination generally would provide a highly reliable new water supply in all water year types. A six-month pilot test was completed in April 2009 at Contra Costa Water District's Mallard Slough Pump Station (MSPS) which confirmed the technical viability of the project. The MSPS site had several benefits including accessibility to Suisun Bay (a potential water source) proximity to power and related utilities, and ease of operations and site use, since the site is owned by Contra Costa Water District.

In 2010, Zone 7 joined the four other agencies to evaluate the project, and in 2011, the five agencies signed an MOU to fund site-specific analyses. In January 2014, Contra Costa Water District completed a site-specific analysis that describes the BARDP as drawing water from the MSPS with a maximum pumping capacity of 25 MGD (CCWD 2014a, 73).

The partner agencies need to establish the necessary formal agreements for defining roles, responsibilities, and obligations. Issues such as ownerships of the desalination plant and conveyance facilities, operational responsibilities, and the transfer of treated water will need to be resolved (MWH 2010). The exact amounts of desalinated water that would be delivered to each partner agency has not yet been determined. If supply were to exceed demand, or if EBMUD were to purchase supply allowing sale or exchange of Mokelumne supply, there may be potential supply benefit to the Mokelumne River watershed and MokeWISE partners. As currently envisioned, the desalination plant would operate under all hydrologic conditions (every year), serving the needs of the SFPUC and Zone 7 and banking the excess production for the agencies' dry year needs (BARDP 2014). An alternative

operating approach would be necessary to provide potential supply to the Mokelumne River watershed.

## Potential Supplies from Demineralization/Desalination

### Groundwater Demineralization

Groundwater demineralization has been implemented outside of the Central Valley for decades. Since 1990, the Santa Ana Watershed Project Authority (SAWPA) has been operating groundwater desalters. They began operation of a 9 MGD groundwater desalter in the Chino Groundwater Basin in 2000 and added another desalter in 2004. SAWPA's goal is to have 40 MGD of groundwater desalting capacity by 2020. Other desalters include the City of Corona's Temescal Basin Desalter, which has been operating since 2002, and Eastern Municipal Water District's Sun City Desalter, which was implemented in 2003 (CVRWQCB 2006, 68). Raw water from the Chino Groundwater Basin has TDS that ranges from 600 mg/L to 1,000 mg/L.

As an example of groundwater demineralization, the Mocho Groundwater Demineralization Plant, operated by Zone 7, is adjacent to both the upper and lower Mokelumne watersheds. Zone 7 provides potable water supplies to Pleasanton, Livermore, Dublin, and Dougherty Valley in the San Francisco Bay Area. The Mocho Groundwater Demineralization Plant began operating in 2009 with the primary goal of decreasing the buildup of salts and minerals in the Livermore Valley Main Groundwater Basin. The plant has 7.7 MGD of RO capacity, which allows Zone 7 to produce 6.1 MGD of demineralized water. The demineralized water is then blended with other supplies, such as surface water, prior to delivery to customers. The remaining 1.6 MGD of mineral concentrate (or brine) is discharged to San Francisco Bay via the DSRSD brine sewer line. Exporting brine out of Livermore Valley to the Bay reduces the amount of salts and minerals re-entering the groundwater basin (Zone 7 2009, 1-3). Influent groundwater hardness (as calcium carbonate) averages 474 mg/L, and total dissolved solids (TDS) averages 692 mg/L. The treated water averages 204 mg/L hardness and 311 mg/L TDS (Witham 2012, 11). Total storage capacity of the Livermore Valley Groundwater Basin is estimated to be approximately 500,000 AF. The groundwater budget is essentially in balance between supply and demand (DWR 2006a, 2). The Eastern San Joaquin Groundwater Subbasin is much larger, and unlike the Livermore Valley Groundwater Basin, it is not in balance from a supply standpoint. The total net outflow of the Eastern San Joaquin Subbasin system exceeds the estimated safe yield of 618,000 AFY, resulting in groundwater overdraft conditions (DWR 2006b, 3). As such, although localized groundwater demineralization opportunities may exist, additional groundwater withdrawal from the basin would further impact the existing overdraft condition and is generally not recommended.

### Desalination Exchange

SFPUC and Zone 7 anticipate needing BARDP supplies every year, creating a minimum BARDP partner demand of 15,700 AFY in all years. EBMUD, SCVWD, and Contra Costa

Water District demands for BARDP water would occur less frequently, creating a maximum demand of up to 51,500 AFY in some dry years. BARDP production is 20,900 AFY. In order to make all partners whole, SFPUC and Zone 7 demands would likely be met in all non-drought years, and BARDP water that is not needed during non-dry years would be stored in Los Vaqueros Reservoir for use during dry years. The analysis completed in the 2014 Site Specific Analyses Final Report assumes that up to 5,200 AFY will be produced by the BARDP in excess of partner demands. It also assumes this amount would be available to store in the reservoir for use during droughts (CCWD 2014a, 115). BARDP is currently sized based on existing and potential demands within the partner agency service areas. As such, no supplemental supply is currently expected to be available from the BARDP. The project capacity and operations would need to be modified to allow additional supply to be produced for exchange with MokeWISE partners.

### Summary of Potential Desalination/Demineralization Supply

Because groundwater within the Eastern San Joaquin Groundwater Basin is considered “critically overdrafted,” groundwater demineralization is not considered a viable supply. While small-scale, local opportunities may exist, additional withdrawal from the groundwater basin would likely exacerbate the groundwater conditions. As such, groundwater demineralization is not anticipated to provide a long-term, regional supply for the MokeWISE program.

Desalination exchange could potentially be a viable water supply in the future. Currently, however, the BARDP is designed to meet the needs of all current partners; any additional partners would require a modification of the design capacity. At this time, desalination exchange is not considered a viable supply alternative.

### Challenges with Maximizing Desalination/Demineralization Supply

Challenges associated with desalination/demineralization as a supply in the MokeWISE program are listed below. These challenges should be considered when discussing desalination or demineralization projects in the MokeWISE program.

- **Institutional challenges.** Large-scale desalination would likely require regional partnerships which can be difficult, expensive, and time-intensive to identify and develop.
- **Groundwater basin conditions.** Demineralization requires uptake of groundwater, which has the potential to exacerbate groundwater overdraft conditions. As mentioned previously, the Eastern San Joaquin Groundwater Basin, while recovering, has historically been overdrafted. Demineralization would allow use of groundwater that has historically been too saline for beneficial use. This additional use of groundwater could potentially exacerbate basin overdraft conditions.
- **Waste stream.** Desalination and demineralization projects produce waste streams. Depending on the scale of the project, this waste stream could present disposal



challenges. For example, the Final EIR for the Davis-Woodland Water Supply Project states that saline water disposal from potential desalination of local groundwater is infeasible due to extremely high costs and other factors related to physical feasibility (Davis 2007).

### **Opportunities for Maximizing Desalination/Demineralization Supply**

The following are potential opportunities for maximizing desalination and demineralization supply. These examples can be considered when discussing potential MokeWISE projects and programs.

- **Use of saline supplies.** As saline intrusion causes groundwater supplies to become more saline over time, desalination may become necessary to allow supplies to continue to be used for irrigation and potable purposes, despite water quality degradation.
- **Solar desalination.** A number of saline supplies, including groundwater and agricultural drainage water, could be treated by solar desalination. Solar desalination removes salts and other impurities from water using solar energy.

## Mokelumne River

### Background

Previous efforts have evaluated the possibility of expanding use of Mokelumne River supplies through arrangements such as an in-river exchange or banking Mokelumne supplies in the Eastern San Joaquin Groundwater Basin. Before such opportunities can be explored, potential unallocated water from the Mokelumne River must be quantified<sup>12</sup>. The proposed methodology to quantify and assess potentially unallocated water is described below.

Unallocated water, as it is used in MokeWISE, is defined as that quantity of water in the Mokelumne River that is not diverted pursuant to a riparian or appropriative water right and that is not required to be in the river pursuant to a prescribed pre-1914 regulatory requirement. This differs from the original MokeWISE Work Plan, which indicated that the Water Availability Analysis would quantify “available water.” Task 4 of the MokeWISE work plan is provided below.

#### *TASK 4: WATER SUPPLY AVAILABILITY ANALYSIS*

*In order to accurately develop a program that optimizes water supply, water quality, and environmental stewardship on an interregional conjunctive management basis, key background information must first be developed. A critical piece of information to be determined is the amount of water that is potentially available in wet years from the Mokelumne River and from other potential sources.*

*Available water supply for conjunctive management will be precisely determined through inter-related investigations of water rights, Mokelumne River hydrology, existing regulatory constraints, and evaluation of potential expansion of surface water storage. The intent is to define potentially available water supply in terms of water rights holders (or potential for acquiring additional rights) and associated volume, timing, and reliability. To conduct hydrologic analysis, the Mokelumne-Calaveras River Simulation Model (MOCASIM) and/or EBMUDSIM simulation models may be used.*

*A Water Supply Availability Analysis methodology will be developed, discussed, and approved by the stakeholder groups.*

---

<sup>12</sup> This analysis has been performed at a feasibility level as part of the MokeWISE Program. It is not designed, nor is it intended to, serve as the basis for a water rights proceeding. Any future water rights application must undergo a separate water availability analysis.

*The methodology will:*

- *Clearly define modeling assumptions and proposed approach to hydrologic modeling;*
- *Propose a mutually-agreeable definition of “available water,” which will take into account human and environmental demands, water rights, and other regulatory constraints;*
- *Identify an approach to analyzing of the potential benefits from high flood flows in wet years, any potential detrimental impacts to the environment from reduced river flows, and the availability of alternative water supply sources*

The following is an excerpt from the work plan for the MokeWISE program, as submitted in the grant application to DWR.

*A key aspect of defining the methodology will be developing a mutually agreeable definition of “available water.” For example, this could be any water above and beyond human and environmental demands, or it could be water above and beyond existing water rights and other regulatory constraints.*

The following section summarizes MCG discussions relating to the above excerpted sections from the scope of work and work plan.

### **Mokelumne Collaborative Group**

As indicated above, MCG members were tasked with developing a definition of “available water.” The MCG struggled to develop a definition of available water that could be mutually agreed upon. After lengthy discussions among the MCG, the Modeling Workgroup, and between entities offline, the MCG ultimately decided to quantify unallocated water within the Mokelumne River in lieu of defining available water at this point in the process. Unallocated water, as it is used in this discussion, is defined as that quantity of water in the Mokelumne River that is not diverted pursuant to a riparian or appropriative water right and that is not required to be in the river pursuant to a prescribed pre-1914 regulatory requirement. Several MCG members do not consider all unallocated water to be available for a project.

In the past, consultants to the Mokelumne River Water and Power Authority have advocated that unallocated, or unappropriated, water is available for appropriation (HDR 2004). Because this assumes that JSA and other riparian flows are sufficient for the health of the river and its ecosystem, a number of Mokelumne River stakeholders have disputed this claim.

To provide a more holistic view of available water in the Mokelumne River, MCG members have proposed to consider adjusting the following variables in conjunction with projects which would divert water from the river or modify its flow.

1. An environmental flow preservation block of water that maintains a defined amount of water above and beyond channel losses, diversions, and instream flow requirements established by the Lodi Decrees and Joint Settlement Agreement (JSA) to be left in the river (or made available for a specific environmental restoration project).
2. An environmental flow preservation percentage that maintains a defined percentage of water in the river after accounting for channel losses, instream flow requirements, baseline diversions, and the flow preservation block of water.

These two variables will be analyzed in conjunction with projects that would either divert water or otherwise modify river flows. The value of each variable may be adjusted iteratively to optimize the environmental and developmental benefits of each given project or portfolio. The final recommendation for water available to a project that diverts water or modifies flow, and the defined flow preservation block of water and percentage values (if any) to be applied, would be determined by the full MCG following iterative model runs.

The optimal application of these variables will vary based on the project being considered. For instance, these variables may be applied in conjunction with the San Joaquin Groundwater Banking and Exchange project concept currently being considered. Analysis of this project concept may include varying levels of each variable to better understand what water may be available and how that definition may affect the Mokelumne River. As stated above, the final recommendation for water available to this project, or any other project in which the variables would be applied, would be determined by the full MCG.

The variables can only be applied when projects are developed thoroughly enough to allow the changes to Mokelumne River flow to be analyzed using the MOCASIM model. Where projects are not defined in sufficient detail to quantify potential changes to Mokelumne River flows, the variables cannot be applied.

It should be noted that these variables are not incorporated in the presented analysis of unallocated Mokelumne River water. They are designed to be incorporated alongside projects. They are mentioned here to capture the history of the MCG discussions regarding unallocated and available water. Quantities of unallocated water in the river were analyzed to understand sensitivity to hydrologic conditions (see Tables 2 through 7).

## **Regulatory Setting**

Surface water rights in the Mokelumne River Watershed basin consist of riparian and pre- and post-1914 appropriative rights. Riparian rights always have priority over appropriative rights, and pre-1914 appropriative rights have priority over post-1914 appropriative rights (WRIME 2007). The following sections summarize the major decisions and orders affecting the management and distribution of Mokelumne River water.

### Decision 100 (1927)

Issued by the State in 1927, Decision 100 approved EBMUD's appropriation application for the Pardee Project and a permit was subsequently issued (WRIME 2007). The SWRCB issued License 11109 to EBMUD for its Pardee Project in 1981.

### Decision 858 (1956)

Decision 858 was issued in 1956 by the State Engineer and had several implications for the Mokelumne River (WRIME 2007). The Decision declared that a permit by a municipality for domestic purposes be considered first in right, regardless of whether it is first in time. EBMUD was declared a municipality. Because CCWD and NSJWCD delivered large portions of their water to agricultural users, they were not declared municipalities. The Decision granted rights to EBMUD to store water in either Camanche and/or Pardee Reservoirs and to directly divert water from the Mokelumne River during December 1 through July 1 for municipal purposes. CCWD was granted the opportunity to develop their water rights as a county of origin, but applications could not exceed 20,000 AFY<sup>13</sup>. Under Application 12842, NSJWCD was granted temporary appropriation of the excess water not used by EBMUD under its Application 13156.

### Decision 1490 (1979)

Decision 1490, issued by the SWRCB in 1979, reduced JVID's diversion under Permit 12167 5,000 AFY to 3,850 AFY. AWA was granted direct diversion rights to 1,150 AFY from the North Fork of the Mokelumne River and 279 AFY from Antelope Creek, and storage rights to 1,600 AFY in Bear Reservoir. However, the maximum diversion that AWA could take from all sources was set at 1,150 AFY (WRIME 2007).

### Decision 1527 (1979)

Also in 1979, the SWRCB issued Decision 1527, which related to an application from El Rio Vineyards for appropriation of 49 AF of water and flow of 11.14 cfs for storage and crop use. While the SWRCB found that water was not available for appropriation from March 1 through July 1 of each year, there was surplus water available from December through February. As such, the SWRCB allowed El Rio Vineyards to divert water to storage (49 AFY) from December to February. Furthermore, El Rio Vineyards had riparian rights to water in the Mokelumne River, so there was no need for a permit to divert water for crop usage during

---

<sup>13</sup> County of origin rights are administered by the SWRCB, but were originally filed by the State Department of Finance in 1927 under "state filings" No. 5647 and 5648. These "reserved" rights are intended to ensure that projects exporting water from the county would not deprive the county of origin of water necessary for the development of the county. These reservations are not forfeitable and are held in perpetuity until released by the SWRCB for use in the county of origin (WRIME 2007).

the growing season; riparian holders were already factored into the releases from Camanche under the agreements between EBMUD and WID (WRIME 2007).

### Water Rights Order 98-08 (1998)

In a declaration established in Water Rights Order 91-07, the SWRCB had declared that the season of unavailability for appropriation in the Mokelumne River includes the months of June through November (WRIME 2007). In WRO 98-08, the SWRCB added the months of March through June to the season of unavailability. The WRO states that the Mokelumne River is fully appropriated March to November from Woodbridge Dam upstream<sup>14</sup>. Additionally, the WRO declares that the Mokelumne River is fully appropriated July to September from the confluence with the San Joaquin River upstream to the Woodbridge Dam, including all tributaries within this reach where hydraulic continuity exists. The following three exceptions exist to the above declarations of appropriation:

- Due to the occasional availability of unappropriated water in the Mokelumne River during the months of March through June, the declaration does not apply to proposed conjunctive projects which are not dependent upon unappropriated water being available in most years but which could utilize unappropriated water when it is available.
- The order does not apply to State Applications 5647 and 5648 and related assignments.<sup>15</sup>
- Applications 29835 and 29855 should be processed normally, pursuant to Title 23 CCR Section 873(b) (5).<sup>16</sup>

---

<sup>14</sup> California Water Codes sections 1205 through 1207 establish a procedure for the SWRCB to declare state water systems fully appropriated either year-round or during certain months. Section 1205(b) states that a such a declaration include “previous water rights decisions [that] have determined that no water remains available for appropriation” (Water Code §1205(b)). Decision 1527 provides the SWRCB with the support needed to declare the Mokelumne fully appropriated.

<sup>15</sup> Filed by the State of California on July 30, 1927. Both applications reserve water for future appropriation from tributaries of the Mokelumne River for domestic and irrigation uses. A portion of Application 5648 was assigned to JVID in 1959 under Permit 12167 and a portion of Application 5647 was assigned to AWA in 1979 under Permit 17579.

<sup>16</sup> These applications were submitted by the Mokelumne River Water and Power Authority. Application 29835 is currently being pursued by San Joaquin County. Title 23 CCR Section 873(b)(5) states that applications determined by the Chief to be consistent with a revised or additional declaration shall be processed normally. If an application is deemed to be inconsistent with the conditions of the revised declaration, the Chief shall provide the applicant a notice which specifies a reasonable time within which the applicant may provide information to show that hydrologic circumstances have changed within the system declared to be fully appropriated, or that other circumstances exist which justify the continued processing of the application.

### Decision 1641 (1999)

The primary purpose of Decision 1641, issued December of 1999, was to address the water quality objectives of the Bay-Delta Water Quality Control Plan, as well as changing points of diversion, place of use, and purpose of use for the State Water Project and the Central Valley Project (WRIME 2007). As part of the discussions on Bay-Delta Plan water quality objectives, EBMUD and a number of other agencies argued that the flows being released under the JSA were sufficient to meet the objectives. Decision 1641 affirms that the JSA releases by EBMUD and WID are sufficient to meet the Bay-Delta Plan water quality objectives. Accordingly, this Decision establishes that both EBMUD and WID are responsible for helping meet Bay-Delta Plan water quality objectives through compliance with the JSA and amends WID's water right licenses to require that WID bypass JSA released flows below Woodbridge Dam, as defined in the JSA (WRIME 2007).

In 2010, the SWRCB released the Delta Flow Criteria Report which determines new flow criteria for the Sacramento-San Joaquin Delta ecosystem necessary to protect public trust resources. Prompted by this Report, the SWRCB is currently updating the Bay-Delta Plan. A draft Substitute Environmental Document has been released, which indicates that the SWRCB is preparing to require additional flow from many tributaries to the San Joaquin River and the Delta, representing an increase in the amounts required by Decision 1641 (SWRCB 2012). It is not known at this time how continued updates to the Bay-Delta Plan will affect the Mokelumne River and Decision 1641.

### Water Rights Order 2000-02 (2000)

WRO 2000-02 was issued by the SWRCB to clarify Decision 1641. In this order, the SWRCB stated that "the Watershed Protection Act [...] does not apply to EBMUD's water rights because EBMUD's project is not part of the Central Valley Project (SWRCB 2000)." In the process of hearings prior to D1641 being issued, NSJWCD argued that they were unfairly denied water rights under D858. WRO 2000-02 stated that "D1641 is not the proper proceeding for the SWRCB to make the kind of change [reversal of the water rights priority set in D858] NSJWCD is requesting (SWRCB 2000)." As such, the SWRCB did not change the priority of the rights established in Decision 858.

The declarations made in WRO 2000-02 were subsequently litigated. In an appellate decision, the court upheld the SWRCB's declaration in Decision 1641 to approve the JSA flows (WRIME 2007). The court also found that Water Code section 11460 does not determine a preference for any particular type of use over another within an area of origin, nor does the section require explanation of why a particular beneficial need for water exists within the area of origin.

### **Protest Dismissal Agreement (2014)**

Since 1990, San Joaquin County (SJC), North San Joaquin Water Conservation District (NSJWCD), Stockton East Water District (SEWD), Central Delta Water Agency (CDWA), South Delta Water Agency (SDWA) and EBMUD have at various times filed petitions with the State Water Board regarding applications, change petitions and protests related to water rights along the Mokelumne River. These petitions and protests have been pending before the State Water Board. In the settlement agreement approved in December of 2014, the parties agreed to work jointly to improve the health and sustainability of the Eastern San Joaquin groundwater basin and to set aside their respective protests and to petition the SWRCB to dismiss their pending protests. The settlement lays out specific agency commitments which could affect the timing and quantity of water available on the Mokelumne. However, due to the timing of its approval, the provisions of the agreement were not incorporated into the modeling results presented herein.

### **Overview of Results**

Unallocated Mokelumne River water was simulated using the Mokelumne-Calaveras Simulation Model (MOCASIM), which simulates in-river flow conditions over the period of record (1953-2010) under specific diversion assumptions. Channel losses and instream flows required by the FERC requirements for Project 137, Lodi Decrees and Joint Settlement Agreement (JSA) are automatically accounted for by the model logic based on hydrologic and storage conditions. Diversions are included as a primary input to the model. Appendix B presents additional information on the MOCASIM model, including how the diversions and flow requirements are prioritized.

Mokelumne River flows and unallocated water were simulated for current (2010) and projected future (2040) baseline levels of diversion. The current baseline was used to approximate in-river flows under current diversion levels and the future baseline was used to approximate in-river flows under future projected levels of diversion based on existing planning documents. Diversions associated with two baseline cases are presented in Table 19 and have been approved for use in MokeWISE by the MCG and the respective entities.



**Table 19: Diversion Assumptions for Current (2010) and Future (2040) Baselines**

<b>Agency</b>	<b>2010 Baseline Diversions (AFY)</b>	<b>2040 Baseline Diversions (AFY)</b>
<b>Amador Water Agency (AWA)<sup>1</sup></b>	8,155	13,925
<b>Calaveras County Water District (CCWD)<sup>2</sup></b>	2,030	2,030
<b>Calaveras Public Utility District (CPUD)<sup>3</sup></b>	1,299	2,542
<b>East Bay Municipal Utility District (EBMUD)<sup>4</sup></b>	241,920	257,600
<b>Jackson Valley Irrigation District (JVID)<sup>5</sup></b>	3,850	2,800
<b>North San Joaquin Water Conservation District (NSJWCD)<sup>6</sup></b>	3,021	20,000
<b>Woodbridge Irrigation District (WID)<sup>7</sup></b>	72,000	72,000
<b>TOTAL</b>	<b>332,275</b>	<b>370,897</b>

<sup>1</sup> 2010 diversions reflect 97% of historic and projected reported total water use in the AWA 2010 Urban Water Management Plan (UWMP), as 97% of supply is surface water from the Mokelumne River. Projected 2040 diversions are extrapolated from the AWA 2010 UWMP, which reports projected demands through 2030. It is understood that demand may differ in the future from what is presented here depending on actual growth and water use in the AWA service area.

<sup>2</sup> Historic and projected diversions reflect actual and projected data presented in the CCWD 2010 UWMP. It should be noted that projected 2040 use could change significantly in future years, and projections are expected to increase in the 2015 UWMP. However, these are the best currently available projections.

<sup>3</sup> CPUD diversions are confirmed by CPUD and are based on the 2008 Master Plan and 2008-2013 usage summary.

<sup>4</sup> EBMUD 2010 and 2040 diversions based on information provided by the EBMUD Water Resources Division for Mokelumne Supplies.

<sup>5</sup> JVID shares a 5,000 AF right under the Central Amador Water Project (CAWP) with AWA and can currently take up to 3,850 AF. AWA anticipates increasing their portion of the right from 1,250 AF to 2,200 AF, which will decrease JVID's portion to 2,800 AF by 2040.

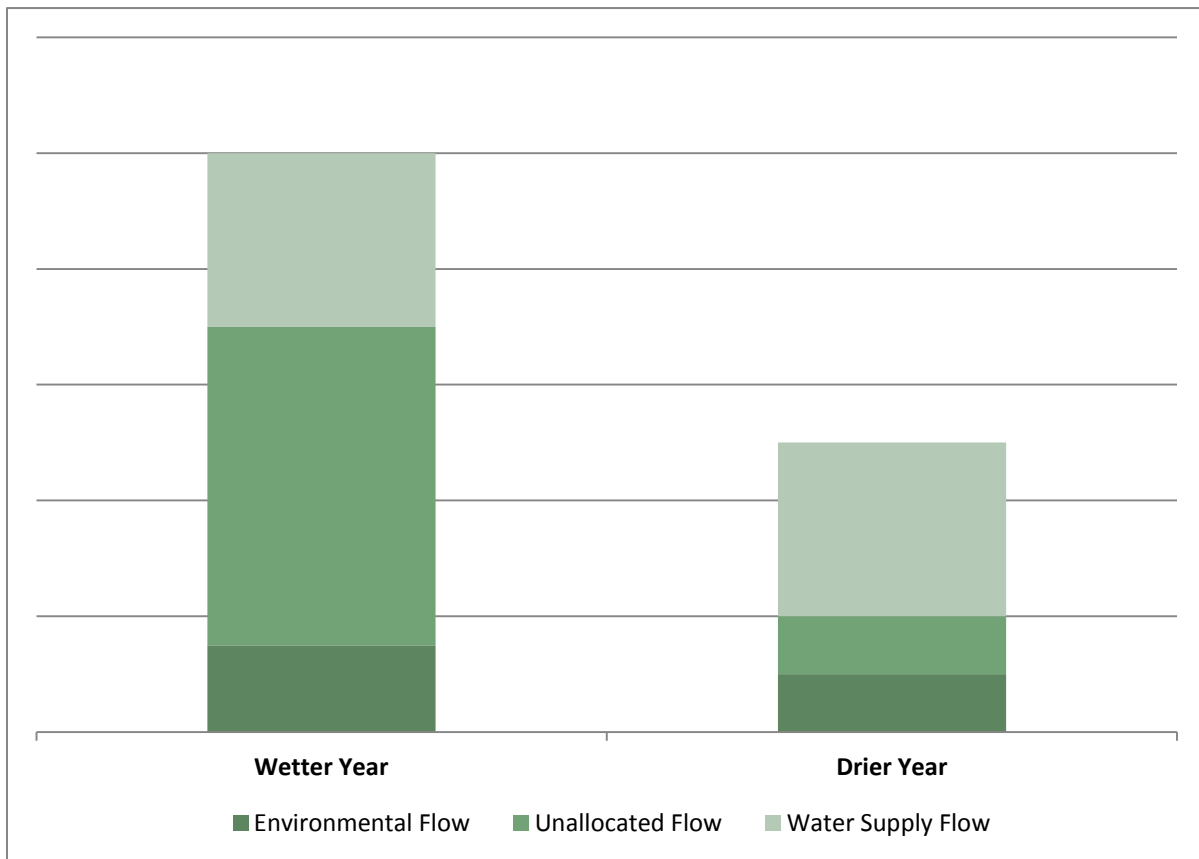
<sup>6</sup> NSJWCD 2010 diversion reflects actual diversions in 2010. Projected 2040 diversions based on capacity and projected demand.

<sup>7</sup> WID can currently take 60,000 AFY, plus additional spill (which is used for irrigation). In recent years, WID has reported diverting 72,000 AFY. The additional spill is obtainable under WID's combined pre 1914 water rights (1886) and the State Water Resources Control Board (SWRCB) licenses 5945 and 8214. WID's simultaneous diversion under License 5945 and the pre-1914 right may not exceed 300 cfs. WID's water right under License 8214 allows 114 cfs to be diverted from the Mokelumne. All combined, diversions cannot exceed 414.4 cfs.

Mokelumne River total in-stream flow and the portion of that flow that is considered to be unallocated were simulated at four locations: (1) below Camanche Reservoir, (2) below Highway 99, (3) below the Woodbridge Diversion Dam, and (4) below Interstate 5 (this location is assumed to be downstream of the last riparian diversion and therefore approximates Mokelumne River inflow into the Delta).

Mokelumne River flow generally consists of several components, including water supply flows, environmental flows, and unallocated flows (see Figure 14). Water supply flows are flows allocated to water users according to existing water rights; in very dry years, some users do not receive all or a portion of their allocation. Environmental flows, including Joint Settlement Agreement (JSA) flows and flows required pursuant to the FERC license for PG&E's project #137, are required at certain regulatory points along the river to ensure a minimum flow for fish and other aquatic wildlife. Unallocated water, as described at the beginning of this chapter, is the water remaining after water supply and environmental flows are accounted. In wetter years when there is more river flow, there is generally more unallocated water; in drier years when there is less river flow, there generally less unallocated water.

**Figure 14: Mokelumne River Flow Components\***



\* This figure is provided as an example to show components of Mokelumne River flow and does not represent actual modeling results.

MOCASIM modeling results, presented in the appendices, present results for both the 2010 and 2040 baselines.

## Summary of Mokelumne River Supply

The amount of unallocated Mokelumne River water is highly variable depending on the location along the River and the hydrologic year type. Generally, there is more unallocated water downstream and less upstream and generally more in normal and below normal years than in dry and critically dry years. Additionally, under both the 2010 and 2040 base case, more water is being released than is required as part of the JSA. There is also generally less unallocated water in the 2040 baseline than in the 2010 baseline, due to the increases in diversions as shown in Table 19.

## Challenges with Optimizing Mokelumne River Water Supply

Challenges associated with optimizing the use of Mokelumne River water as a supply in the MokeWISE program are listed below. These challenges should be considered in conjunction with any MokeWISE projects or programs that include the use of Mokelumne River water.

- **Balancing competing interests.** There are a number of competing interests for Mokelumne River water. Optimizing consumptive use of Mokelumne River water would likely leave less in the river for fish, geomorphic work, ecosystem health, and other wildlife, while maximizing flows within the Mokelumne River would likely leave less for consumptive use. Balancing these competing interests is an inherent challenge when discussing potential uses of Mokelumne River water.
- **Variable flow.** The Mokelumne River is subject to both flood and drought, which results in flows that vary from year to year. This inherent variability of supply has the potential to make optimizing the use of Mokelumne River water challenging.
- **New diversions.** Current facility limitations at existing diversions, such as North San Joaquin Water Conservation District, may limit the ability to divert unallocated water. Permitting new diversions is a significant challenge associated with optimizing consumptive Mokelumne River water.
- **Banking.** Banking of Mokelumne River water could result in challenges associated with the management of withdrawals, particularly regarding monitoring and reporting.
- **Regulatory requirements.** The Joint Settlement Agreement and other regulatory agreements governing the Mokelumne River are not static and are subject to change. Any increase in required flows would likely decrease the amount of unallocated water available.

## Opportunities for Optimizing Mokelumne River Water Supply

- **Supply source for direct/in-lieu banking.** As mentioned in the Groundwater Opportunities section, Mokelumne River water could potentially be used as a source for a direct or in-lieu groundwater banking project or program. In wet or above normal years, unallocated Mokelumne River water could be banked for use in dry years.
- **Ecosystem/wildlife benefits.** Maximizing other sources of water for consumptive or conjunctive use and foregoing the use of Mokelumne River water for additional consumptive use could potentially provide ecosystem and wildlife benefit opportunities, including fishery benefits.

## Other Surface Water

Surface water supplies throughout California are currently heavily subscribed. However, short-term and long-term transfer opportunities may be available through other agencies to assist in meeting needs within the Mokelumne River watershed.

Water transfers involve one agency purchasing supply from another agency. Surface water transfers require a seller to either release additional supply from storage to be used by the buyer, or for a seller to forego use of a portion of its supply such that it may be used by the buyer in a direct diversion. Water transfers may be either short-term, or long-term. For the purposes of this study, short-term transfers are those transfers that are in effect for one year or less, while long-term transfers are transfers that occur for more than one year. Because the MokeWISE program seeks a long-term water supply solution, short term transfers are generally not expected to be desirable. However, some short-term transfers may evolve into long-term transfers over time.

The following sections summarize non-Mokelumne River surface water supplies that could potentially be available to a MokeWISE program project. Due to the significant conveyance and permitting requirements associated with transferring water from users south of the Delta to the MAC and ESJ regions, this section focuses on opportunities to receive water transfers from watersheds north of the Delta. In addition, it should be noted that water transfers that involve conveying water through the Delta are subject to significant carriage losses and permitting hurdles. Existing Freeport facilities could potentially be utilized through an agreement with EBMUD to transfer supplies from north of the Delta to the MAC or ESJ IRWM Regions, as could new conveyance facilities that have not been conceptualized or constructed as part of this study. While Freeport facilities have the benefit of already being in place, capacity and cost limitations and potential institutional hurdles associated with using these facilities should be considered in assessing future transfer opportunities.

## Transfer Opportunities

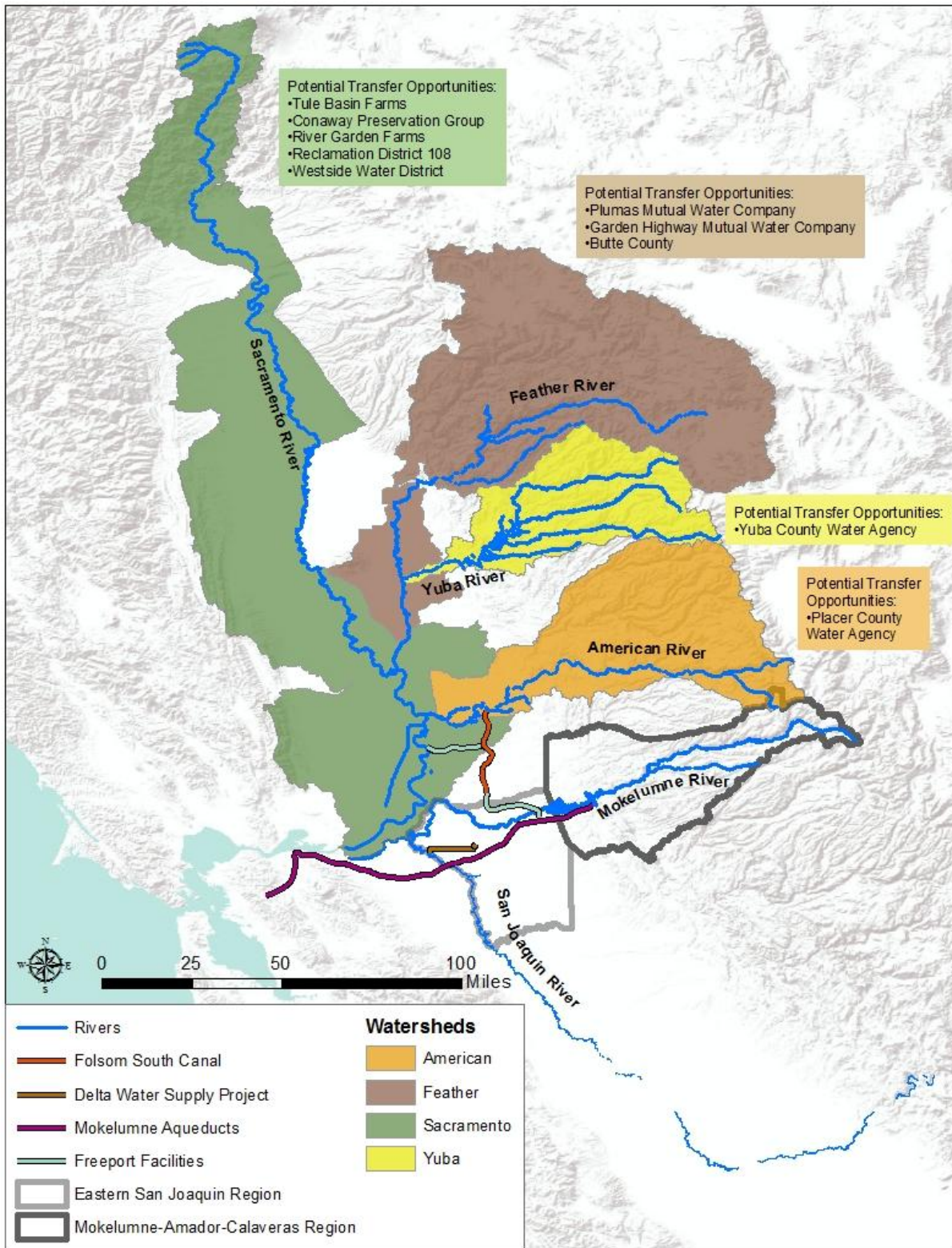
Water transfers are implemented throughout California each year on a wide scale. Water transfers are regulated by several entities, depending on the details of the transfer. The State Water Resources Control Board (SWRCB) regulates transfers involving any surface water rights established after 1914 that involve changes in purpose, place of use, or point of diversion (PPIC 2012a). The Department of Water Resources, California Department of Fish and Wildlife, US Bureau of Reclamation, US Fish and Wildlife Service, and the National Marines Fisheries Services are also involved in approving and managing transfers in California (DWR 2014).

The SWRCB tracks recent water transfers. Figure 15 shows the location of agencies engaged in recent transfers in relation to the MAC and ESJ IRWM Regions. Table 20 provides a summary of water transfers approved by the SWRCB between 2012 and 2014. As shown in this table, a variety of agencies have transferred supplies in recent years. These examples are presented to provide a snapshot of recent transfer activities.

Transfer activity varies significantly over time. For the purposes of this study, transfers may be most attractive during wet and normal years, when supplies could potentially be stored for use in dry years through a conjunctive use arrangement. Transfers are generally in greater demand in dry years than normal and wet years; as such, reviewing recent transfers may provide an inaccurate picture of what may actually be available in wet and normal years. Conversely, dry year transfer contract agreements (which are generally more valuable due to supply pressures) may limit the ability of suppliers to provide wet- or normal- year transfers due to the need to store supplies to meet dry year obligations.

It should be noted that the actual quantity of available supply is assumed to be significantly greater than what is shown in the following sections. However, potential impacts associated with transfers and the complexity of conveying and permitting transfers increases significantly with quantity. Additional coordination with potential partner agencies would be required to determine the exact amount of transfer water potentially available and associated permitting, conveyance, and institutional requirements.

**Figure 15: Examples of Recent Water Transfers in Relation to the MAC and ESJ Regions**



**Table 20: Recent Water Transfers<sup>1</sup>**

<b>Transferring Agency</b>	<b>Receiving Agency(ies)</b>	<b>Source Watershed</b>	<b>Transfer Amount (AFY)</b>	<b>Begin Date</b>	<b>End Date</b>
<b>DWR/USBR</b>	Santa Clara Valley Water District, Oak Flat Water District/Del Puerto Water District, Kern County Water Agency/Kern Tulare Water District	Trinity/Delta/San Joaquin	52,320	10/24/2012	10/23/2013
<b>Merced Irrigation District</b>	U.S. Bureau of Reclamation	Merced	180,000	effective April/May of 2012 and 2013	6/1/2013
<b>U.S. Bureau of Reclamation on behalf of Arvin-Edison Water Storage District</b>	Metropolitan Water District of Southern California	San Joaquin River, American River, Old River, Sacramento River, Trinity River, Clear Creek, Rock Slough	100,000	4/2/2012	4/1/2013
<b>Placer County Water Agency</b>	Westlands	Sacramento	20,000	6/27/2013	6/26/2014
<b>Department of Water Resources</b>	Santa Clara, Metropolitan	Trinity/Delta	196,000	7/1/2013	6/30/2014
<b>Tule Basin Farms</b>	Kern County, Dudley Ridge, Empire West Side	Sutter Bypass	3,520	7/1/2013	6/30/2014

<sup>1</sup> 2012, 2013, and 2014 water transfers under Water Code Section 1725, reported by the SWRCB



**Table 20: Recent Water Transfers<sup>1</sup>**

<b>Transferring Agency</b>	<b>Receiving Agency(ies)</b>	<b>Source Watershed</b>	<b>Transfer Amount (AFY)</b>	<b>Begin Date</b>	<b>End Date</b>
<b>Garden Highway Mutual Water</b>	Kern County, Dudley Ridge	Feather River	5,000	7/1/2013	6/30/2014
<b>Eastside Mutual Water Co</b>	San Luis & Delta Mendota	Sacramento	1,100	7/1/2013	6/30/2014
<b>Reclamation District No. 1004</b>	San Luis & Delta Mendota	Sacramento	7,175	7/1/2013	6/30/2014
<b>Pleasant Grove-Verona Mutual Water Company</b>	San Luis & Delta Mendota	Sacramento	2,000	7/1/2013	6/30/2014
<b>Conaway Preservation Group</b>	San Luis & Delta Mendota	Sacramento	8,000	7/1/2013	6/30/2014
<b>David &amp; Alice te Velde Revocable Family Trust</b>	San Luis & Delta Mendota	Sacramento	1,320	7/2/2013	7/1/2014
<b>City of Sacramento, Sac Suburban Water District</b>	Dudley Ridge Water District, Empire-West Side Irrigation District, Kern County Water Agency	American River	3,658	7/3/2013	7/2/2014
<b>Walker River Irrigation District</b>	Instream flow dedication to Walker Lake (not drought related)	Walker River	25,000	2/21/2014 - Transfer begins upon federal District Court approval	One year from federal District Court approval

Table 20: Recent Water Transfers<sup>1</sup>

Transferring Agency	Receiving Agency(ies)	Source Watershed	Transfer Amount (AFY)	Begin Date	End Date
<b>Department of Water Resources/U.S. Bureau of Reclamation** (joint petition)</b>	Santa Clara Valley Water District, Oak Flat Water District, Del Puerto Water District, Kern County Water Agency, Kern Tulare Water District, Arvin-Edison Water Storage District , Metropolitan Water District of Southern California, Westlands Water District, Dept. of Veterans Affairs - San Joaquin Valley National Cemetery, Musco Olive Products, Inc.	Trinity/Delta/San Joaquin -- No North of Delta Water - Therefore, No Fishery Assistance	277,863	approved 3/28/2014 transfer begins 4/1/2014	5/1/2015
<b>Placer County Water Agency</b>	East Bay Municipal Utility District	American River -- Assists with Lower American River Flows Beginning 4/2/2014	20,000	4/2/2014	5/2/2014
<b>Reclamation District 756</b>	Semitropic Water Storage District, Kern County Water Agency, Alameda County Water District, Zone 7 Water Agency, Santa Clara Valley Water District	San Joaquin River -- In Delta Transfer, No Fishery Assistance	11,603	5/12/2014	9/30/2014

**Table 20: Recent Water Transfers<sup>1</sup>**

<b>Transferring Agency</b>	<b>Receiving Agency(ies)</b>	<b>Source Watershed</b>	<b>Transfer Amount (AFY)</b>	<b>Begin Date</b>	<b>End Date</b>
<b>Delta Farms Reclamation District 2026</b>	Semitropic Water Storage District, Kern County Water Agency, Alameda County Water District, Zone 7 Water Agency, Santa Clara Valley Water District	San Joaquin River -- In Delta Transfer, No Fishery Assistance	9,131	5/12/2014	9/30/2014
<b>Merced Irrigation District</b>	San Luis and/or Santa Clara Valley	Merced River -- Yes, Pulse Flow for Fishery Assistance April 2014	5,000	4/22/2014	10/19/2014
<b>Garden Highway Mutual Water Company</b>	San Luis & Delta-Mendota Water Authority	Feather River - No Identified Fishery Component	7,500	Transfer Denied Because Water Right Curtailed 6/10/2014	
<b>Plumas Mutual Water Company</b>	Feather River - No Identified Fishery Component	State Water Contractor Agencies (County of Kings, Dudley Ridge Water District, Kern County Water Agency, Oak Flat Water District, Napa County FCWCD)	5,000	Transfer Denied Because Water Right Curtailed 6/10/2014	
<b>Department of Water Resources</b>	Westlands Water District	Feather River - No Identified Fishery Component	15,225	6/9/2014	9/30/2014

**Table 20: Recent Water Transfers<sup>1</sup>**

<b>Transferring Agency</b>	<b>Receiving Agency(ies)</b>	<b>Source Watershed</b>	<b>Transfer Amount (AFY)</b>	<b>Begin Date</b>	<b>End Date</b>
<b>South Sutter Water District</b>	State Water Contractor Agencies (County of Kings, Dudley Ridge Water District, Kern County Water Agency, Oak Flat Water District, Napa County FCWCD)	Bear River - No Identified Fishery Component	10,000	7/7/2014	9/30/2014
<b>Placer County Water Agency</b>	Westlands Water District	American River -- Assists with Lower American River Flows	35,000	7/8/2014	7/8/2015
<b>U.S. Bureau of Reclamation/ Contra Costa Water District</b>	Alameda County Water District	Old River/ Middle River - No Identified Fishery Component	5,000	7/11/2014	9/30/2014
<b>Department of Water Resources</b>	San Luis & Delta-Mendota Water Authority	Feather River - No Identified Fishery Component	6,600	7/11/2014	7/11/2015
<b>U.S. Bureau of Reclamation/ Contra Costa Water District</b>	Byron-Bethany Irrigation District	Old River/ Middle River - No Identified Fishery Component	4,000		

As seen in the previous table, several agencies are currently involved in the transfer market that may have supplies available for transfer. Examples of recent transfers are summarized below.

### Example Recent Short-Term Transfers

#### *Placer County Water Agency*

Placer County Water Agency (PCWA) began transferring water in 2000 with the formation of the Sacramento Water Forum Agreement. This agreement states that PCWA will release water from its reservoirs in dry years only, if there is a willing buyer downstream of the confluence of the Sacramento and American Rivers (EBMUD 2012a). Based on preliminary discussions, up to 47,000 AF per year of dry-year transfer water may be available through this opportunity. This is an opportunity that is currently being pursued by EBMUD, though PCWA has been receptive to EBMUD partnering with other agencies (EBMUD 2013, 10).

PCWA is currently engaged in a short-term transfer with Westlands Water District (SWRCB 2014b). This 35,000 AF transfer assists with Lower American River Flows, in addition to providing water to Westlands. The transfer began on July 8, 2014 and terminates July 8, 2015, at which point all or a portion of this water may become available on the open market. PCWA also initiated a one-month transfer with EBMUD in April of 2014 for 20,000 AF (SWRCB 2014b).

#### *Garden Highway Mutual Water Company (GHMWC)*

In 2010, GHMWC sold 5,802 AF to a number of agencies including Kern County, Metropolitan Napa County Flood Control and Water Conservation District, and Dudley Ridge (SWRCB 2010a). In 2013, GHMWC sold 5,000 AF to Kern County, Dudley Ridge, and Empire-West Side in a short-term transfer agreement that terminated on June 30, 2014 (SWRCB 2013, 1-2).

In 2014, the Garden Highway Mutual Water Company (GHMWC) attempted to enter into a short-term transfer agreement with San Luis and Delta-Mendota Water Authority for 7,500 AF. This transfer was ultimately denied because the water right was curtailed on June 10, 2014 (SWRCB 2014b).

#### *Conaway Preservation Group*

In 2013, the Conaway Preservation Group entered into an agreement with San Luis and Delta Mendota Water Authority for a transfer of 8,000 AF, which terminated on June 30, 2014 (SWRCB 2013).

### *Tule Basin Farms*

In 2010, Tule Basin Farms (TBF) sold 3,520 AF to a number of agencies, including Antelope Valley-East Kern, Dudley Ridge, and Kern County (SWRCB 2010a). This short-term transfer lasted for three months and ended on September 30, 2010. This same amount of water was transferred again in 2013 to Kern County, Dudley Ridge, and Empire-West Side (SWRCB 2013, 1-2). This transfer agreement was executed on July 1, 2013 and ended on June 30, 2014.

### *Plumas Mutual Water Company*

In 2014, Plumas Mutual Water Company (MCWP) attempted to enter into a short-term transfer agreement for 5,000 AF of Feather River water with a number of State Water Contractor agencies, including Kings County, Dudley Ridge Water District, Kern County Water Agency, and Oak Flat Water District. This transfer was ultimately denied because the water right was curtailed on June 10, 2014 (SWRCB 2014b).

### *Reclamation District 108*

In 2009, Reclamation District 108 transferred 2,805 AF of water in a short-term transfer to the 2009 Drought Water Bank. This was a three month transfer that ended on September 30, 2009 (SWRCB 2009).

### *River Garden Farms*

In 2009, River Garden Farms initiated a short-term transfer of 3,500 AF to the 2009 Drought Water Bank (SWRCB 2009). This was a 3-month transfer that ended on October 31, 2009.

## **Example Recent Long-Term Transfers**

### *Yuba County Water Agency*

Yuba County Water Agency (YCWA) has been engaging in water transfers since 1987. In 2008, the Lower Yuba River Accord initiated a long-term transfer for the environment and state and federal water contractors, totaling 60,000 AF per year (EBMUD 2012b; EBMUD 2014; YCWA *nd*). This transfer agreement terminates in 2025.

### *Butte County*

In 2012, Butte County, a long-time State Water Project contractor, entered into two long-term transfer agreements, both lasting for two years (PPIC 2012b, 25). The first, for 24,832 AF, involved sales to a number of agencies within the San Joaquin Valley region, including Dudley Ridge Water District, Belridge Water Storage District, and Berrenda Mesa Water District. The second was for 10,429 AF and served Palmdale Water District in Southern California (PPIC 2012b, 25). Both of these transfers ended in 2014.

*Westside Water District*

In 1998, Westside Water District entered into a 25-year transfer agreement with Colusa County Water District, selling 25,000 AFY (PPIC 2012b, 23). Because this agreement was initiated in 1998 with a 25-year lifespan, this water would not be available until 2023.

**Delta Supplies**

While the Delta is fully appropriated, there may be additional water available in the Delta during flood flows. Utilization of flood flows for a MokeWISE project would require a new water right to be secured, which would involve a significant regulatory and permitting process.

In August 2010, the SWRCB identified potential new Delta flow criteria (SWRCB 2010b). Analysis using CalSimII indicates that there may be surplus Sacramento River and Delta supplies if the identified flow criteria were to be adopted as new flow requirements (Bourez 2010a). Table 21 shows the percentage of time during each month when surpluses would be present (Bourez 2010b).

**Table 21: Percent of Time Surplus can be Expected to be Available if SWRCB Adopts Delta Flow Criteria as Flow Requirements**

<b>Oct</b>	<b>Nov</b>	<b>Dec</b>	<b>Jan</b>	<b>Feb</b>	<b>Mar</b>	<b>Apr</b>	<b>May</b>	<b>Jun</b>	<b>Jul</b>	<b>Aug</b>	<b>Sep</b>	<b>Annual</b>
0%	4%	21%	34%	29%	13%	2%	0%	0%	0%	0%	0%	61%

Based on this analysis, if the new flow criteria were adopted, water could be reasonably expected to be available in November through April. This water is not currently available, but could become available in the future should the SWRCB modify current Delta flow requirements.

Flood flows that reach the Delta may also be available for transfer. While estimating the average potential amount available during flood flows is difficult, it can generally be assumed that flood flows on the magnitude of what has been observed historically could potentially be captured and put to beneficial use. Furthermore, if the flow criteria identified by the SWRCB in 2010, or any more stringent requirements were to be adopted, flood flows would still be expected to be available for use (Bourez 2010a). Again, it should be noted that utilization of flood flows for a MokeWISE project would require a new water right to be secured, which would involve a significant regulatory and permitting process.

## Transfer Conveyance Alternatives

Depending upon the location and type of transfer, various conveyance alternatives may be considered. Existing Freeport Regional Water Project Facilities may provide the most feasible alternative for conveying a north of Delta transfer to the MAC or ESJ Region. Potential conveyance alternatives and related constraints are discussed below.

### Freeport Regional Water Project Facilities

The Freeport Regional Water Project is a jointly owned intake facility on the Sacramento-San Joaquin River Delta. A cooperative effort between EBMUD and the Sacramento County Water Agency (SCWA), Freeport serves surface water supplies from the Sacramento River to customers in both Sacramento County and the East Bay (Freeport Regional Water Authority [FRWA] 2008). The facility can convey roughly 185 million gallons per day (mgd), with SCWA receiving 85 MGD in all years and EBMUD receiving 100 MGD in dry years only (San Joaquin County 2009, ES-1). While Freeport is operated at capacity in dry years, conveyance capacity is expected to be available during wet and normal years, which are expected to occur in two of every three years, on average (San Joaquin County 2009, ES-1; EBMUD 2014 personal communication). Unassigned EBMUD capacity within Freeport facilities could potentially be utilized to facilitate through-Delta transfers.

As defined by EBMUD, unassigned capacity is any capacity dedicated to EBMUD remaining in Freeport facilities after meeting all EBMUD needs (EBMUD 2005). Third parties interested in utilizing this unassigned capacity must meet one or more of the four objectives outlined by EBMUD:

1. Deliver water to improve reliability for EBMUD customers;
2. Deliver water as an alternate supply to facilitate maintenance of Mokelumne facilities;
3. Protect and restore or enhance the environment of the Delta and its tributaries, and mete water conservation and recycling objectives as defined by the Bay-Delta program;
4. Minimize EBMUD capital and operation cost for the Freeport Regional Water Facility Project (EBMUD 2005).

Third parties utilizing EBMUD unassigned capacity would be required to enter into an agreement with EBMUD, which would include obtaining advance permit approvals and securing funding for the use of Freeport facilities. As such, unassigned capacity may be determined to meet the fourth objective.

Costs associated with the use of Freeport facilities would be expected to range from \$400-500 per AF if supplies are not mized with EBMUD Mokelumne supplies, or \$800-\$900 if the transfer water were combined with Mokelumne River water (EBMUD 2014 personal communication). These costs would increase the overall unit cost of the transfer water accordingly.



### **Delta Water Supply Project Facilities**

The Delta Water Supply Project (DWSP) is owned and operated by the City of Stockton and serves customers with water from the San Joaquin River. The intake is located at the southwestern tip of Empire Tract on the San Joaquin River and has a capacity of 33,600 AFY (30 MGD) (Stockton 2011, 4-2). The City of Stockton has planned to use the full capacity of the DWSP; however, records indicate that the City typically only utilizes 11 MGD of capacity (Stockton 2011; Stockton 2014b). While the City of Stockton may increase its capacity use in the future, this facility could provide an opportunity for use in transfer agreements. The cost of raw water delivery through DWSP facilities is significantly lower than Freeport, estimated at roughly \$200 per AF (Stockton 2011, 127).

### **Contra Costa Canal Facilities**

The Contra Costa Canal is owned and operated by the Contra Costa Water District to draw water from the Delta under a contract with the Central Valley Project (CVP). Contra Costa is the CVP's largest urban contractor. Part of the CVP, the canal is a 48-mile long aqueduct that begins at Rock Slough in East Contra Costa County and ends at the Terminal Reservoir in the City of Martinez (CCWD 2014b). Water is diverted from both Rock Slough and Old River near Discovery Bay. Water diverted at Rock Slough travels through 4 miles of unlined channel before reaching the concrete-lined canal (CCWD 2014b). Water diverted at Old River can either be delivered to Los Vaqueros Reservoir or to the Contra Costa Canal. There may be some capacity in the Contra Costa Canal in certain hydrologic year types that could be purchased for use.

### **Summary of Potential Other Surface Water Supply**

Transfer potential is estimated based on a review of transfers tracked by the SWRCB in 2012-2014. Of these years, the greatest quantity of transfers was approved on 2014, totaling nearly 412,000 AF in that year. However, conveyance of these supplies would likely present a significant hurdle. If Freeport facilities were to be used for conveyance, potential supply would be limited by capacity constraints of the existing facilities. As such, the potentially available supply from other surface water is assumed to be limited to the conveyance capacity of Freeport facilities. As discussed previously, Freeport facilities can convey roughly 185 MGD, with SCWA receiving 85 MGD in all years and EBMUD receiving 100 MGD in dry years only (San Joaquin County 2009, ES-1). In normal and wet years, if EBMUD's 100 MGD were used for a MokeWISE project, approximately 112,000 AFY could be delivered for a MokeWISE project in normal and wet years.

### **Challenges with Maximizing Other Surface Water Use**

Challenges associated with other surface water as a supply in the MokeWISE program are listed below. These challenges should be considered when discussing transfer or other surface water projects in the MokeWISE program.

- **Conveyance constraints.** Freeport currently provides the biggest potential for infrastructure conveyance of transfers, which potentially limits the amount of water that can be transferred. However, there may be additional infrastructure which can be used to transfer water in the future.
- **Partnership-building.** Transfers require partnership building. Agencies interested in transfers must identify water available on the market and build relationships with those agencies selling water. Identifying these agencies and building the relationships necessary to enter into a transfer agreement can be difficult, expensive, and time-consuming. Relationships also needed for developing in-lieu exchanges of the water diverted and treated at Freeport or Stockton.
- **Economic feasibility.** Transfers and use of other surface water can be expensive. As mentioned above, use of Freeport facilities is costly due to high pumping costs and additional facilities needed to convey it an agency. In dry years, water available on the transfer market will be costly due to high demand. While agencies can partner to realize cost-sharing benefits, this requires partnership-building.
- **Seasonal and yearly conditions.** Additional information on availability of potential transfers under various seasonal conditions and year types is needed to refine the estimates provided.
- **Institutional challenges.** Transfers and use of other surface water would likely require regional coordination and partnerships which can be difficult, expensive, and time-intensive to identify and develop. There may be pumping limitations and other future regulatory constraints which could potentially limit availability. Additionally, storage arrangements to ensure that wet year transfers are available in dry year could be challenging.

## Opportunities for Maximizing Other Surface Water Use

The following are potential opportunities for maximizing other surface water use. These examples can be considered when discussing potential MokeWISE projects and programs.

- **Banking programs.** Opportunities may exist to implement banking programs with urban water utilities in adjacent watersheds, improving groundwater levels.
- **Freeport facilities.** Unused capacity within the Freeport facilities could be used, through agreements with EBMUD, to convey transfer supplies to users in the Mokelumne River watershed. These supplies could potentially offset the use of Mokelumne River water.
- **Operational modifications.** Modified operation of existing storage facilities and other infrastructure could potentially free up new water that could be available for transfer or exchange with Mokelumne River users.
- **Storage facility sharing.** Partnerships could be developed among agencies needing to store transfer water and agencies with storage capacity to allow storage facilities to be used in exchange for money or additional water during other times of year.

## Summary of Potentially Available Supply

Estimated quantities of supplies potentially available from each of the sources considered, including groundwater, agricultural drainage water, recycled water, stormwater, conservation, desalination, Mokelumne River, and other surface water, are summarized below and shown in Table 22.

### Groundwater

- While currently used in the upper watershed, groundwater is not considered a viable additional source in Amador and Calaveras counties due to low yield, unreliability, age of groundwater, and limited storage opportunities.
- The Eastern San Joaquin Groundwater Basin is considered critically overdrafted.
- Groundwater is not considered a viable additional supply source, although conjunctive use and recharge opportunities may be available.

### Agricultural Drainage Water

- While quantities of agricultural drainage water are unknown, it is assumed that they are currently minimal and decreasing due to investments in agricultural irrigation efficiency practices and technologies. As such, this is not considered a viable source.
- Some local, small-scale applications may be viable for capturing agricultural drainage, but it is not expected to provide a viable regional water supply.
- It is generally accepted that there is usually a user that will take agricultural drainage water downstream for use.

### Recycled Water

- The total quantity of potentially available recycled water is estimated to be 222,500 AFY; however, that amount is reduced to roughly 169,400 AFY after accounting for challenges and constraints associated with the treatment and distribution of recycled water.
- Potential recycled water available in the future within the upper watershed, lower watershed, and EBMUD service area is estimated to be 3,489 AFY, 3,050 AFY, and 162,857 AFY, respectively. However, full use of this supply is not realistic due to monetary costs, coordination costs, and market potential.
- Of the up to 169,400 AFY potentially available, an estimated 126,720 AFY of secondary treated and 42,680 AFY of tertiary treated recycled water is available in the future.

### **Stormwater**

- Total potentially available stormwater within the MokeWISE region is between 14,939 AFY and 15,560 AFY. This amount includes the municipal systems in Lodi and Stockton and the residential areas in both the upper and lower watersheds.
- The municipal system in Lodi could potentially yield 3,550 AFY and the system in Stockton could potentially yield 11,370 AFY, totaling 14,920 from municipal systems.
- Residential areas in the MokeWISE region could potentially yield an estimated 20 AFY, with 3 AFY from the upper watershed and 17 AFY from the lower watershed, assuming rainfall capture occurred from April to October. If rainfall capture occurred all year long, the upper watershed could capture 90 AFY and the lower watershed could capture roughly 550 AFY.

### **Conservation**

- Using water savings assumptions from the CUWCC and the applicable agencies, the estimated quantity of water that could potentially be available in the future under expanded implementation of BMPs is between 173,000 and 175,000 AFY. This number is assumed to be low, as the savings for several BMPs were unable to be determined due to data gaps.
- Under a theoretical maximum conservation program where agencies could reduce to 85 gpcd, anticipated future savings in 2040 would be roughly 350,000 AFY.
- Agricultural efficiency could potentially conserve roughly 170,000 AFY by 2030.

### **Desalination**

- Groundwater demineralization requires additional withdrawal from the groundwater basin, which could exacerbate the existing overdraft condition.
- While desalination exchange could potentially yield available water in the future, the BARDP as currently sized is designed to meet the needs of all current partners. Additional partners would require a modification of the design capacity.
- At this time, neither groundwater demineralization nor desalination exchange are considered viable supplies.

### **Mokelumne River**

- Supply of unallocated water is highly variable based on year type and River location.
- Generally, there is more unallocated water in wet and above normal years than in below normal, dry, and critically dry years.
- Modeling indicates that under both 2010 and 2040 baselines, more water is being released at both JSA compliance points than is required as part of the JSA.

### **Other Surface Water**

- The total estimated quantity of short-term transfers available is 85,325 AFY, while long-term transfers potentially provide an additional 127,261 AFY. However, more information on availability under various seasonal conditions and year types is needed to refine this estimate.
- Other surface water may include unappropriated flood flows or water that may potentially be available under a new flow regime. These quantities, while variable and difficult to determine, may potentially provide additional available water to the MokeWISE program.

**Table 22: Summary of Potentially Available Supply by Source**

<b>Supply Type</b>	<b>Type of Supply Available</b>	<b>Amount of Supply Available (AFY)</b>	<b>Challenges</b>	<b>Opportunities</b>
Groundwater	N/A	Not quantified	<ul style="list-style-type: none"> <li>• Availability</li> <li>• Groundwater basin conditions</li> </ul>	<ul style="list-style-type: none"> <li>• Direct/in-lieu banking</li> <li>• Direct injection</li> </ul>
Agricultural Drainage Water	N/A	Not quantified	<ul style="list-style-type: none"> <li>• Downstream impacts</li> <li>• Treatment</li> </ul>	<ul style="list-style-type: none"> <li>• Soil flushing</li> </ul>
Recycled Water	<ul style="list-style-type: none"> <li>• Secondary treated</li> <li>• Tertiary treated</li> </ul>	169,499	<ul style="list-style-type: none"> <li>• Timing and storage</li> <li>• Economic feasibility</li> <li>• Coordination costs</li> <li>• Infrastructure requirements</li> <li>• Benefit allocation</li> <li>• Market potential</li> <li>• Local considerations</li> <li>• Scalability</li> <li>• Groundwater basin proximity</li> <li>• Downstream impacts</li> </ul>	<ul style="list-style-type: none"> <li>• Non-potable uses</li> <li>• Saline intrusion barrier</li> <li>• Indirect potable reuse/direct potable reuse</li> <li>• Direct injection</li> </ul>
Stormwater	<ul style="list-style-type: none"> <li>• Municipal</li> <li>• Residential</li> </ul>	14,939	<ul style="list-style-type: none"> <li>• Storage and timing of demand</li> <li>• Downstream impacts</li> <li>• Rain barrel requirements</li> <li>• Treatment and conveyances for large-scale systems</li> <li>• Groundwater recharge</li> </ul>	<ul style="list-style-type: none"> <li>• Large-scale detention basins</li> <li>• Low impact development</li> <li>• Land purchases</li> <li>• Formal on-site reuse programs</li> <li>• Offset surface water</li> </ul>

**Table 22: Summary of Potentially Available Supply by Source**

<b>Supply Type</b>	<b>Type of Supply Available</b>	<b>Amount of Supply Available (AFY)</b>	<b>Challenges</b>	<b>Opportunities</b>
Conservation	<ul style="list-style-type: none"> <li>• Municipal</li> <li>• Agricultural</li> </ul>	173,357.7 – 350,756.9	<ul style="list-style-type: none"> <li>• Downstream impacts</li> <li>• Growth impacts</li> <li>• Economic feasibility</li> </ul>	<ul style="list-style-type: none"> <li>• Further implementation of BMPs</li> <li>• Implementation of additional BMPs</li> <li>• Infrastructure improvements</li> <li>• Altering rate structures</li> </ul>
Desalination	<ul style="list-style-type: none"> <li>• Groundwater demineralization</li> <li>• Desalination exchange</li> </ul>	Not quantified	<ul style="list-style-type: none"> <li>• Institutional challenges</li> <li>• Groundwater basin conditions</li> <li>• Waste stream</li> </ul>	<ul style="list-style-type: none"> <li>• Use of saline supplies</li> <li>• Solar desalination</li> </ul>
Mokelumne River	Unallocated water	Variable*	<ul style="list-style-type: none"> <li>• Balancing competing interests</li> <li>• Variable flow</li> <li>• New diversions</li> <li>• Banking</li> </ul>	<ul style="list-style-type: none"> <li>• Supply source for direct/in-lieu banking</li> <li>• Ecosystem/wildlife benefits</li> </ul>
Other Surface Water	<ul style="list-style-type: none"> <li>• Short-term transfers</li> <li>• Long-term transfers</li> <li>• Unappropriated Delta water</li> </ul>	212,585**	<ul style="list-style-type: none"> <li>• Downstream impacts</li> <li>• Growth impacts</li> <li>• Economic feasibility</li> </ul>	<ul style="list-style-type: none"> <li>• Further implementation of BMPs</li> <li>• Implementation of additional BMPs</li> <li>• Infrastructure improvements</li> <li>• Altering rate structures</li> </ul>

\* Dependent on year type and location on the Mokelumne River.

\*\* Dependent on flood flows, hydrologic year type, and/or amount of water in Delta.

## References

- Aegis Engineering Management & Zw3 (Aegis). 2013. *Amador Water Agency: Regional Approach for Reuse Study*. February 2013.
- Amador LAFCO. 2014. *Municipal Service Review for Amador County 2014*. 2014.
- Amador Water Agency (AWA). 2011. *Urban Water Management Plan 2010*. September 2011.
- Aquacraft, Inc. Water Engineering and Management. 2011. *California Single Family Water Use Efficiency Study*. 1 June 2011. Available at:  
<http://www.irwd.com/images/pdf/save-water/CaSingleFamilyWaterUseEfficiencyStudyJune2011.pdf>
- Bay Area Regional Desalination Project website accessed here:  
<http://www.regionaldesal.com/> on 8/5/2014.
- Black & Veatch Corporation (B&V). 2003. *City of Lodi Stormwater Management Program*. January 2003.
- Bourez, Walter. 2010a. *Exhibit WDCWA-100, Woodland Davis Clean Water Agency Testimony of Walter Bourez, P.E.*
- Bourez, Walter. 2010b. *Exhibit WDCWA-104, Woodland Davis Clean Water Agency Testimony of Walter Bourez, P.E.*
- Calaveras County Water District (CCWD). 2011. *Urban Water Management Plan 2010 Update*. June 2011.
- Calaveras Local Agency Formation Commission (Calaveras LAFCO). 2012. *Final Water and Wastewater Municipal Service Review (MSR)*. June 2012.
- Calaveras Public Utility District (CPUD). 2008. *Calaveras Public Utility District Water System Master Plan*. October 2008.
- CPUD. 2014a. General Information (Fees, Maps, Statistics). Accessed here:  
[http://www.cpubd.org/sys\\_stats\\_map/system\\_stats\\_map.html](http://www.cpubd.org/sys_stats_map/system_stats_map.html) on 8/12/14.
- CPUD. 2014b. Personal communication with Donna Leatherman, District Manager, CPUD. 11 September 2014.
- California Data Exchange Center (CDEC). 2014. *Precipitation Averages for Station IDs CPD, WPT, LOD, and STK*.



- California Urban Water Conservation Council (CUWCC). 2011. *Memorandum of Understanding Regarding Urban Water Conservation in California*. Amended September 14, 2011.
- Carollo. 2013. *District Wide Master Plan Volume 1 – Executive Summary*. January 2013.
- Central Valley Regional Water Quality Control Board (CVRWQCB). 2006. *Salinity in the Central Valley, an Overview*. May 2006.
- CVRWQCB. 2007. *2007 Review of Monitoring Data for the Irrigated Lands Conditional Waiver Program*. July 13, 2007.
- CVRWQCB. 2013. *Response to Comments for the City of Jackson Wastewater Treatment Plant Tentative Waste Discharge Requirements*. December 2013.
- Contra Costa County Sanitary District (CCCSD). 2014. Available at: <http://www.centalsan.org/index.cfm?navid=7>. Accessed: July 31, 2014.
- Contra Costa Local Agency Formation Commission (Contra Costa LAFCO). 2014. *Combined Municipal Service Review and Sphere of Influence Study (2<sup>nd</sup> Round)*. May 2014.
- Contra Costa Water District (CCWD). 2014a. *Bay Area Regional Desalination Project Site Specific Analyses Final Report, Delta Modeling Tasks*. January 2014.
- CCWD. 2014b. *District Profile, Contra Costa Water District*. Available at: <http://www.ccwater.com/welcome/profile.asp>. Accessed: 9 December 2014.
- Cooley, Heather, Juliet Christian-Smith, and Peter H. Gleick. *More with Less: Agricultural Water Conservation and Efficiency in California, A Special Focus on the Delta*. Pacific Institute. September 2008.
- Davis, City of. 2007. *Davis-Woodland Water Supply Project Final Environmental Impact Report*. October 2007. Available at: [http://www.wdcwa.com/docs/Final Environmental Impact Report.pdf](http://www.wdcwa.com/docs/Final_Environmental_Impact_Report.pdf)
- Department of Water Resources (DWR). 2006a. *California's Groundwater Bulletin 118, Livermore Valley Groundwater Basin*. 1/20/2006.
- DWR. 2006b. *California's Groundwater Bulletin 118, San Joaquin Valley Groundwater Basin, Eastern San Joaquin Subbasin*. 1/20/2006.
- DWR. 2013. *WSIHIST Chronological Reconstructed Sacramento and San Joaquin Valley Water Year Hydrologic Classification Indices*. 19 December 2013. Available at: <http://cdec.water.ca.gov/cgi-progs/iodir/WSIHIST>.

- DWR. 2014. *Water Transfers Activities: Management of Water Transfers in California and DWR's Role*. 6 February 2014.
- Dublin San Ramon Sanitary District (DSRSD). 2011. *2010 Urban Water Management Plan*. June 2011.
- Dunn Environmental, Inc. 2012. *Calaveras County Ground Water Quality Sampling Plan Portions of the Eastern San Joaquin Ground Water Basin, Supplement to the 2012 USGS Report Efforts*. December 2012.
- East Bay Municipal Utility District (EBMUD). 2005. *Principles for Use by Other Parties of Unassigned EBMUD Capacity in Freeport Regional Water Project Facilities*. 8 February 2005.
- EBMUD, California Department of Fish and Game, US Fish and Wildlife Service. 2008. *Lower Mokelumne River Project Joint Settlement Agreement Ten-Year Review*. September 2008. Available at:  
[https://www.ebmud.com/sites/default/files/pdfs/JSA%20Partnership%2010-year%20review%20final%2009-10-08\\_1.pdf](https://www.ebmud.com/sites/default/files/pdfs/JSA%20Partnership%2010-year%20review%20final%2009-10-08_1.pdf)
- EBMUD. 2011. *EBMUD 2011 Urban Water Management Plan*. June 2011.
- EBMUD. 2012a. *Water Transfers Update Planning Committee Presentation*. 8 May 2012.
- EBMUD. 2012b. *Memorandum: Water Transfers Update*. 3 May 2012.
- EBMUD. 2012c. *Water Supply Management Program 2040 Plan*. April 2012.
- EBMUD. 2013. *Water Supply Management Program Board of Director's Workshop Presentation*. 22 January 2013.
- EBMUD. 2014. Personal communication with Jan Lee, Senior Civil Engineer; Richard Sykes, Manager of Natural Resources; Tom Francis, Senior Civil Engineer; Michael Tognolini, Manager of Water Supply Improvements, EBMUD. 24 July 2014.
- Freeport Regional Water Authority (FRWA). 2008. *Project Info*. Available at:  
<http://www.freeportproject.org/nodes/project/index.php>
- Henningson, Durham and Richardson, Inc. (HDR). 2004. *Mokelumne River Regional Water Storage and Conjunctive Use Project – MORE WATER Feasibility Analysis/Environmental Documentation Phase I – Reconnaissance Study Summary Report*. June 2004. Available at:  
<http://www.morewater.org/pdf/MORE%20WATER%20Phase%20I%20Report.pdf>
- HDR. 2013. *Pinole/Hercules Water Pollution Control Plant: Preliminary Design Executive Summary*. March 6, 2013.

- Hydroscience. 2012. *City of Sutter Creek and Amador Regional Sanitation Authority Wastewater Master Plan*. 26 November 2012.
- Jackson, City of. 2008. *General Plan Land Use Element*. November 2008.
- Jackson, City of. 2012. *Wastewater Treatment Plant Improvement Project Draft Environmental Impact Report*. July 2012.
- Jackson Valley Irrigation District. 2014. Personal communication with Steve Fredrick, General Manager JVID. 8 September 2014.
- K.S. Dunbar & Associates, Inc. (KSD). 2012. *City of Ione Wastewater Compliance Project: Initial Study/Mitigated Negative Declaration*. December 2012.
- Larry Walker Associates (LWA). 2009. *City of Stockton & County of San Joaquin: Final Stormwater Quality Control Criteria Plan*.
- Lodi, City of. 2008. *City of Lodi Stormwater Development Standards Plan*.
- Lodi, City of. 2011. *City of Lodi 2010 Urban Water Management Plan*. June 2011.
- Lund, Jay and Ryan Cahill. 2011. *Can California further reduce urban water use?* California WaterBlog. 8 June 2011. Available at:  
<http://californiawaterblog.com/2011/06/08/can-california-further-reduce-urban-water-use/>
- Montgomery Watson Harza (MWH). 2009. *Calaveras County General Plan: Water Element Baseline Report Supplement*. February 2009.
- MWH. 2010. *Pilot Testing at Mallard Slough Pilot Plant Engineering Report*. June 2010.
- National Land Cover Database (NLCD). 2011. Available:  
<http://www.mrlc.gov/nlcd2011.php>.
- National Oceanic and Atmospheric Administration (NOAA). 2014. Annual Summaries Station Details for Station ID COOP:045032. Accessed on 10 September 2014. Available:  
<http://www.ncdc.noaa.gov/cdo-web/datasets/ANNUAL/stations/COOP:045032/detail>.
- Northeastern San Joaquin County Groundwater Basin Authority (GBA). 2004. *Eastern San Joaquin Groundwater Basin Groundwater Management Plan*. September 2004.
- GBA. 2007. *Eastern San Joaquin Integrated Regional Water Management Plan*. July 2007.
- Northwest Alliance for Computational Science & Engineering (NACSE). 2012. PRISM Climate Group 30-year Normal Precipitation: Annual (1981-2010). Accessed on: 30 July 2014. Available: <http://www.prism.oregonstate.edu/normals/>.

- Oro Loma Sanitary District (Oro Loma). 2013. *Oro Loma Sanitary District: 2013-2014 Statistical Information Sheet*. June 1, 2013.
- Pinole, City of. 2014. Available at: [http://www.ci.pinole.ca.us/publicworks/treat\\_plant.html](http://www.ci.pinole.ca.us/publicworks/treat_plant.html). Accessed: July 31, 2014.
- Plymouth, City of. 2014. Personal communication with Jeff Gardner, City Manager at the City of Plymouth. 16 September 2014.
- PPIC. 2012a. *California's Water Market, By the Numbers: Update 2012*. November 2012.
- PPIC. 2012b. *Technical Appendices: California's Water Market, By the Numbers: Update 2012*. November 2012.
- RMC Water and Environment (RMC). 2011. *City of Lodi 2010 Urban Water Management Plan*. June 2011.
- RMC. 2012. *Camanche Area Regional Water Supply Plan (CARWSP) Feasibility Study and Conceptual Design*. 2 January 2012.
- RMC. 2013. *Mokelumne/Amador/Calaveras Integrated Regional Water Management Plan Update*. January 2013.
- San Joaquin County. 2009. *Freeport Element of the American River Use Strategy, Phase I: Draft Feasibility Study, Volume 1: Report*. August 2009.
- San Joaquin County and Delta Water Quality Coalition. 2008. *San Joaquin County and Delta Water Quality Coalition Management Plan, Irrigated Lands Regulatory Program*. September 30, 2008.
- San Joaquin County and Delta Water Quality Coalition. 2014. Website accessed here: <http://www.sjdeltawatershed.org/> on July 25, 2014.
- San Joaquin County Flood Control and Water Conservation District (SJCFCWD). 2014. *Groundwater Report, Spring 2014*.
- San Leandro, City of. 2014. *About us*. Available at: <https://www.sanleandro.org/depts/pw/wpcp/about.asp>. Accessed: July 31, 2014.
- State Water Resources Control Board (SWRCB). 2000. *Order WR 2000-02: Order Denying Petitions for Reconsideration and Amending SWRCB Decision 1641*. Available at: [http://www.waterboards.ca.gov/waterrights/board\\_decisions/adopted\\_orders/orders/2000/wro2000-02.pdf](http://www.waterboards.ca.gov/waterrights/board_decisions/adopted_orders/orders/2000/wro2000-02.pdf)

- SWRCB. 2009. *2010 Delta Water Transfers*. 2009. Available at:  
[http://www.swrcb.ca.gov/waterrights/water\\_issues/programs/water\\_transfers/docs/2009transfertable.pdf](http://www.swrcb.ca.gov/waterrights/water_issues/programs/water_transfers/docs/2009transfertable.pdf)
- SWRCB. 2010a. *2010 Delta Water Transfers*. 2010. Available at:  
[http://www.swrcb.ca.gov/waterrights/water\\_issues/programs/water\\_transfers/docs/2010transfertable.pdf](http://www.swrcb.ca.gov/waterrights/water_issues/programs/water_transfers/docs/2010transfertable.pdf)
- SWRCB. 2010b. *Developed of Flow Criteria for the Sacramento-San Joaquin Delta Ecosystem ("The Delta Flow Criteria Report")*. Available at:  
[http://www.waterboards.ca.gov/waterrights/water\\_issues/programs/bay\\_delta/delta\\_flow/docs/final\\_rpt080310.pdf](http://www.waterboards.ca.gov/waterrights/water_issues/programs/bay_delta/delta_flow/docs/final_rpt080310.pdf)
- SWRCB. 2012. *Public Draft Substitute Environmental Document in Support of Potential Changes to the Water Quality Control Plan for the San Francisco Bay-Sacramento/San Joaquin Delta Estuary: San Joaquin River Flows and Southern Delta Water Quality*. December 2012. Available at:  
[http://www.waterboards.ca.gov/waterrights/water\\_issues/programs/bay\\_delta/bay\\_delta\\_plan/water\\_quality\\_control\\_planning/2012\\_sed/](http://www.waterboards.ca.gov/waterrights/water_issues/programs/bay_delta/bay_delta_plan/water_quality_control_planning/2012_sed/)
- SWRCB. 2013. *2013 Water Transfers Under Water Code Section 1725*. Available at:  
[http://www.swrcb.ca.gov/waterrights/water\\_issues/programs/water\\_transfers/docs/2013transferstable.pdf](http://www.swrcb.ca.gov/waterrights/water_issues/programs/water_transfers/docs/2013transferstable.pdf)
- SWRCB. 2014a. *Agriculture, Irrigated Lands Regulatory Program*, accessed here:  
[http://www.swrcb.ca.gov/water\\_issues/programs/agriculture/](http://www.swrcb.ca.gov/water_issues/programs/agriculture/) on July 25, 2014. Website last updated 7/15/14.
- SWRCB. 2014b. *2014 Water Transfers Under Water Code Section 1725*. Available at:  
[http://www.swrcb.ca.gov/waterrights/water\\_issues/programs/water\\_transfers/docs/2014transfertable.pdf](http://www.swrcb.ca.gov/waterrights/water_issues/programs/water_transfers/docs/2014transfertable.pdf)
- SWRCB. 2014c. *Emergency Conservation Regulation Update*. 4 November 2014. Available at:  
[http://www.waterboards.ca.gov/waterrights/water\\_issues/programs/drought/docs/emergency\\_regulations/uwc\\_pres110414\\_item6.pdf](http://www.waterboards.ca.gov/waterrights/water_issues/programs/drought/docs/emergency_regulations/uwc_pres110414_item6.pdf)
- Stockton, City of. 2011. *2010 City of Stockton Urban Water Management Plan*. 26 May 2011.
- Stockton, City of. 2013. GIS Data – Zoning. Available:  
<http://www.stocktongov.com/services/gis/mapdatDat.html>.
- Stockton, City of. 2014a. Personal communication with Mel Lytle, Director of City of Stockton Municipal Utilities. 10 September 2014.

- Stockton, City of. 2014b. *City of Stockton Regional Wastewater Treatment Facility and Water Treatment Facility Water Discharge and Draw Data*. 4 August 2014. U.S. Geologic Survey (USGS). 2011. USGS National Land Cover Database (NLCD) 2011 Percent Developed Imperviousness. Accessed on: 30 July 2014. Available: [http://www.mrlc.gov/nlcd11\\_data.php](http://www.mrlc.gov/nlcd11_data.php).
- URS. 2007. *Bay Area Regional Desalination Project Feasibility Study, Final Draft*. July 2007.
- USGS. 2006. *Sources of High-Chloride Water to Wells, Eastern San Joaquin Ground-Water Subbasin, California*. November 2006. Available at: <http://pubs.usgs.gov/of/2006/1309/pdf/ofr2006-1309.pdf>.
- USGS. 2012. *Test Drilling and Data Collection in the Calaveras County Portion of the Eastern San Joaquin Groundwater Subbasin, California, December 2009 – June 2011*.
- Wagner & Bosnignore, CCE. 2014. *Groundwater Resources Management Report, Documentation of Duck Creek Reservoir Feasibility Investigation and Supporting Documentation of Water Right Application Amendment*. April 2014.
- Water Code, California. Division 2, Part 2, Chapter 1, Article 1.3, Section 1205-1207. Available at: <http://www.leginfo.ca.gov/cgi-bin/displaycode?section=wat&group=01001-02000&file=1205-1207>
- Witham, Trude. 2012. *Worth Their Salt*. November/December 2012 issue of *Water System Operator*. Available at: [http://www.tpomag.com/editorial/2012/12/worth\\_their\\_salt\\_wso](http://www.tpomag.com/editorial/2012/12/worth_their_salt_wso)
- Woodbridge Irrigation District (WID). 2013. *2014 Agricultural Water Management Plan*. September 2013.
- WID. 2014. Personal communication with Anders Christensen, General Manager of Woodbridge Irrigation District. 28 August 2014.
- WRIME 2007. *Technical Briefing: Water Rights Review prepared for the Mokelumne River Forum*. December 2007.
- Yuba County Water Agency. No date. *Water Purchase Agreement Technical Brief*. Available at: <http://www.ycwa.com/documents/627>
- Zone 7 Water Agency. 2009. *Mocho Groundwater Demineralization Plant Reduces Water Hardness, Enhances Reliability*. July 23, 2009. Available at: [http://www.zone7water.com/images/pdf\\_docs/fact\\_sheets/mocho\\_factsheet\\_7-23-091.pdf](http://www.zone7water.com/images/pdf_docs/fact_sheets/mocho_factsheet_7-23-091.pdf)

# **Appendix A: East Bay Municipal Utility District Stormwater Capture and Use Evaluation Scope of Services**

Appendix A presents the scope of work for a stormwater quantification project currently being implemented by EBMUD.

## EXHIBIT A

### East Bay Municipal Utility District Stormwater Capture and Use Evaluation

#### SCOPE OF SERVICES

##### I. CONSULTANT SERVICES

CONSULTANT shall provide the following:

###### Contracted Services

###### **Task A. Estimation of Theoretical Stormwater Supplies**

Kickoff Meeting - Discussion of EBMUD Goals and Data Availability before starting the Task A work effort, CONSULTANT's project manager and a GIS analyst will meet with EBMUD staff to confirm the project goals, agree upon the number of scenarios to assess, and review available GIS data.

The methodology for estimating theoretical stormwater supplies will be presented to the District's project manager for approval or modification as a deliverable of Task A and may change slightly depending on the District's available GIS data sources. Our proposed methodology is as follows:

1. CONSULTANT will delineate the project area in GIS by masking the five (5) terminal reservoirs out of the EBMUD service area. This will require GIS data from EBMUD (service area and terminal watersheds).
2. CONSULTANT will delineate the relevant watersheds and/or constructed hydrologic divides using GIS data from EBMUD where available, supplemented by the East Bay creek watershed boundaries from the Museum of California, and USGS topographic database for watersheds east of the hills. CONSULTANT will divide the EBMUD service area watersheds into two rainfall areas: east and west of the hills. For each watershed, CONSULTANT will use EBMUD data or if needed estimate monthly rainfall in the following water year types: wet, average, moderate drought, severe drought and critical drought.
3. To allow EBMUD to assess the effects of climate change by 2040, two estimates of future rainfall and evaporation (for landscape irrigation usage) will be made using downscaled monthly IPCC data. The scenarios will be RCP8.5 (high climate change) and RCP4.5 (medium low climate change forcing).
4. For each watershed, CONSULTANT will identify the number and average size of properties in each customer category using GIS data from EBMUD. CONSULTANT will utilize some of the 21 land cover classes within EBMUD's Irrigation Reduction Information System (IRIS) to estimate average roof area and landscape irrigation needs



aggregated to the watershed and customer category level. Based on a pilot test conducted by CONSULTANT for the Peralta Creek watershed, CONSULTANT anticipates collecting data on single and multiple family residences, commercial and institutional properties. CONSULTANT will investigate the potential for rainfall / stormwater capturing on properties in the industrial and petroleum category, but anticipate that water quality issues and limitations on suitable uses for the water harvested may limit the potential for this customer category, as with irrigation users. CONSULTANT will estimate rainfall / stormwater capture area for existing land use conditions (2015) and projected forwards to 2040 land use conditions, using the information developed under WSMP 2040. IRIS data analyzed from this task will also support the water reuse calculation (Task B).

5. For each watershed, CONSULTANT will identify the area of municipal open space that could be utilized for regional-scale projects using Contra Costa and Alameda County GIS data. CONSULTANT will examine each watershed in GIS and identify 3-4 potential representative open space opportunities per watershed for regional water capture, to serve as typical sites. CONSULTANT will make unit area estimations of runoff volume under each water year type using the Rational Method with local parameters, and scaled up from the typical projects to the entire watershed based on the number and area of such sites apparent in GIS.
6. CONSULTANT will estimate the theoretical water volume that could be supplied by the stormwater system by taking the impervious area within each watershed and assuming that all rainfall to impervious areas eventually enters the stormwater system. CONSULTANT would assume that all rainfall to pervious surfaces is lost to infiltration or evapotranspiration. CONSULTANT will estimate stormwater runoff for the different watersheds and water years.
7. For each watershed, CONSULTANT will identify the documented water quality issues and competing water needs such as minimum instream requirements for creeks (using publically available data from EBMUD, SF Bay RWQCB, NOAA Fisheries, and CDF&W). CONSULTANT will perform a desk-based reconnaissance-level groundwater opportunities and constraints assessment.
8. In order to assess the potential effects of a rainwater / stormwater harvest program on instream flows, CONSULTANT will scale up the results of the sub-watershed rainfall-runoff model we previously developed for the City of Oakland rain barrel effectiveness study to the EBMUD project watersheds. CONSULTANT will do this by scaling up the water capture volumes that were assessed in the Oakland program into the Bay Area Hydrology Model that CONSULTANT developed for that project, and running the model (a continuous rainfall-runoff model) to estimate the change in peak flow and baseflow for receiving creeks. This will provide a basis for estimating not just the available instream flows (baseflows), but the potential reduction in peak flows (a potential ancillary benefit to EBMUD for stormwater treatment and first flush management). CONSULTANT does not propose to model the entire EBMUD service area: the model will be a representative unit area that can be scaled up to mimic entire watersheds.

9. CONSULTANT will aggregate the potential supplies from the sources in subtasks A1-9 to identify the total volume of water that could theoretically be harvested for each watershed in each customer category while meeting instream flow requirements and other relevant regulations.

**Deliverables**

CONSULTANT will provide the District with a discussion of the proposed methodology that will be used for calculating theoretical rainwater / stormwater supplies. The methodology will include the approach for considering catchment areas as well as all data sources and calculation methods. Once approved by the District, the CONSULTANT will perform the estimate and prepare a technical memorandum summarizing the work effort. The main deliverable for this task will be a technical memorandum (TM) presenting estimates of theoretical water supplies from all EBMUD service area watersheds except those draining to the five terminal reservoirs, broken down into single-family residential, multi-family residential, commercial categories.

EBMUD staff will provide comments to a draft TM. Edits and/or comments will be used by the CONSULTANT team to prepare a final TM for Task A.

**II. PROJECT SCHEDULE**

The project schedule assumes that the consultant receives a written Notice to Proceed from EBMUD on or before December 9<sup>th</sup> 2014. If the Notice to Proceed is received later than this date the schedule will be set back by the equivalent number of days.

<i>Task</i>	<i>Deliverable</i>	<i>Date Due</i>
Notice to Proceed	-	December 9 <sup>th</sup> 2014
0	Kickoff meeting	December 14 <sup>th</sup> 2014
A	Draft technical memo	January 30 <sup>th</sup> 2014
A	Final technical memo	February 27 <sup>th</sup> 2015

## **Appendix B: Conservation BMP Estimates by Agency**

Appendix B presents further information on the conservation analysis, including the methodology and assumptions used to quantify the conservation BMPs for each agency.

## Amador Water Agency

AWA prepared and adopted a Water Conservation Plan in 2010 which included descriptions of the fourteen BMPs, the current level of implementation, and plan for future implementation. This Plan was incorporated into its 2010 UWMP including estimated levels of implementation of each conservation measure for Fiscal Year (FY) 2012 through FY 2016. AWA estimated potential water savings for BMPs 2, 5, 6, 9, and 14 using assumptions provided in the CUWCC MOU, as well as the existing number of single family accounts, multi-family accounts, potable and raw water accounts, and other parameters (see Table B-1). The BMPs are described in the following sections.

**Table B-1: AWA's Estimated Water Savings for Select BMPs (AFY)**

BMP	FY11-12	FY12-13	FY13-14	FY14-15	FY15-16
2. Residential Plumbing Retrofit	2.7	5.4	5.4	5.4	5.4
5. Large Landscape Conservation Programs and Incentives	3.9	5.3	5.3	5.3	5.3
6. High-Efficiency Clothes Washing Machine Financial Incentive Programs	0.9	1.7	1.7	1.7	1.7
9. Conservation Programs for Commercial, Industrial, and Institutional (CII) Accounts	2.0	3.0	3.0	3.0	4.0
14. ULFT Replacement Programs	0.4	0.9	0.9	0.9	0.9
<b>Total</b>	<b>12.1</b>	<b>20.8</b>	<b>20.8</b>	<b>20.8</b>	<b>21.8</b>

Source: AWA 2011.

### 1. Water Survey Programs for Single-Family Residential and Multi-Family Residential Customers

AWA has had an informal water survey program since 1985, but it formalized the BMP in its 2010 UWMP. It conducts residential and landscape water surveys, and distributes WaterSense Specification (WSS) (i.e. low-flow) showerheads and faucet aerators. The surveys include both indoor and outdoor surveys and suggestions for both single family and multi-family residences. Because AWA did not provide an estimated water savings associated with this BMP, the potential savings that could be achieved were calculated. Assuming that CCWD and AWA have similar customer profiles, the assumptions used by CCWD are applied to AWA. This assumes a 15 percent savings per customer per water survey which would result in 68 gallons per day (gpd) per single family unit and 40 gpd per multi-family unit per survey conducted.

**Current Program:** In AWA’s 2010 UWMP, it assumed it would complete the number of surveys shown in the following table.

**Table B-2: AWA Projected Water Survey Program**

	<b>FY12</b>	<b>FY13</b>	<b>FY14</b>	<b>FY15</b>	<b>FY16</b>
<b># single family surveys</b>	50	100	100	100	100
<b># multi-family surveys</b>	1	1	2	3	4
<b># landscape surveys</b>	50	100	100	100	100

AWA would save 3.9 AFY if it performs surveys for 50 single family homes and 1 multi-family home. According to the AWA 2010 UWMP, it had 6,319 single family connections and 30 multi-family connections in 2010. Therefore, in FY12, AWA planned to perform surveys for 0.8 percent of its single family accounts and 3.3 percent of its multi-family accounts. If AWA maintains these current levels of implementation and performs surveys on 0.8 percent and 3.3 percent of its single and multi-family accounts in 2040, AWA can expect to conserve 6.7 AFY.

Knowing population will continue to increase in the AWA service area, there is greater potential for water savings if the number of surveys performed increase as population increases. Population was projected through 2030 in the AWA 2010 UWMP as shown in the following table.

**Table B-3: AWA Population**

<b>2010</b>	<b>25,640</b>
<b>2015</b>	27,880
<b>2020</b>	30,448
<b>2025</b>	33,374
<b>2030</b>	36,766
<b>2040</b> <b>(estimated)*</b>	44,395

\* The Department of Finance estimates Amador County population at 38,334 in 2040.

Assuming the population growth rate in the AWA service area grows at the same rate from 2030 to 2040 as it did from 2020 to 2030, the population in 2040 would be 44,395. Single family customers account for 24.6 percent of the population and multi-family customers account for 0.1 percent. Assuming the same percentages in 2040, based on a population of

44,395, there would be 10,941 single family accounts in the AWA service area and 52 multi-family accounts.

Expanded (Double) Program: If AWA were to expand the program by doubling the current implementation rates (1.6 percent for single family and 6.7 percent for multi-family), it would perform 100 single family surveys and 2 multi-family surveys. In 2040, AWA would perform 173 single family surveys and 3 multi-family surveys, saving 13.3 AFY.

Expanded (Quadruple) Program: If AWA doubled its expanded program, it would conduct 200 single family surveys and 4 multi-family surveys (reaching 3.2 percent and 13.3 percent of customers, respectively). Under the doubled expanded program in 2040, AWA would conduct 346 single family surveys and 7 multi-family surveys. This would result in a savings of 26.7 AFY.

In summary, the following water savings could be achieved:

- BMP 1, 2010 Water Savings Based on UWMP: 3.9 AFY
- BMP 1, 2040 Water Savings if Current Implementation Level is Maintained: 6.7 AFY
- BMP 1, 2040 Savings if Expanded (Double): 13.3 AFY
- BMP 1, 2040 Savings if Expanded (Quadruple): 26.7 AFY

## 2. Residential Plumbing Retrofit

AWA plans to combine this BMP with BMP 8 – School Education Programs. Outreach will be conducted to fifth graders at schools in the AWA service area, and WSS showerheads will be provided to the students to install with their parents/guardians.

Current Program: AWA did not budget for this BMP until FY12. Thus, no savings are associated with this BMP in 2010. In FY13 and each year after (through its planning period of FY16), AWA planned to provide WSS showerheads to all fifth graders. The number of fifth graders is expected to increase over time as population in the service area increases. In 2010, 389 fifth graders equated to 1.5 percent of the AWA service area population. In 2040, using the same population percentage, there would be 674 fifth graders. If AWA provides WSS showerheads to all 674 fifth graders, water savings of 9.4 AFY would be achieved (assuming 0.014 AFY water savings per showerhead replaced).

Expanded (Double) Program: As stated above, AWA did not budget for this BMP until FY12. In FY12, AWA planned to provide showerheads to half of all fifth graders (roughly 195 students), resulting in a water savings of 2.7 AFY. Because the BMP is assumed to be fully implemented under its current program by 2040, there would be no additional water savings associated with this BMP in 2040.

Expanded (Quadruple) Program: If AWA doubled its expanded program in 2010, it would reach all fifth graders. Because the BMP is assumed to be fully implemented under its current program by 2040, there would be no additional water savings associated with this BMP in 2040.

In summary, implementation of BMP 2 achieves the following:

- BMP 2, 2010 Water Savings Based on BMP: 0 AFY
- BMP 2, 2040 Water Savings if Current Implementation Level is Maintained: 9.4 AFY
- BMP 2, 2040 Water Savings if Expanded (Double): 9.4 AFY
- BMP 2, 2040 Water Savings if Expanded (Quadruple): 9.4 AFY

### 3. System Water Audits, Leak Detection and Repair

AWA implements this BMP through ongoing repair and maintenance of its water distribution system. It has conducted system water audits since its founding. AWA plans to conduct an annual pre-screening audit of its entire system, then if indicated by the pre-screening audit, a system-wide detailed water audit will be completed. Water savings have not been quantified since detailed information on AWA leaks before and after BMP implementation is not available. New requirements in SB 1420, which mandates Urban Water Management Plans, will require agencies to determine unaccounted-for water (UAW).

### 4. Metering with Commodity Rates for All New Connections and Retrofit of Existing Connections

AWA has been converting services from flat rate to metered service upon transfer of ownership. As of 2011, there were 27 residential, commercial and raw water customers requiring metering, and 153 accounts yet to be converted from flat rate to volumetric billing. According to the 2010 UWMP, AWA should have fully metered its system as of 2013 and converted all accounts to volumetric billing. This BMP is fully implemented. Water savings have not been quantified since detailed information on customer water use patterns before and after BMP implementation is not available.

### 5. Large Landscape Conservation Programs and Incentives

There are approximately 30 accounts that are dedicated solely to large landscape irrigation in the AWA service area. AWA has offered surveys to these accounts, along with commercial, industrial, and institutional (CII) accounts since 1985 as an informal service.

**Current Program:** The BMP was formalized in its 2010 UWMP. The BMP was not budgeted until FY12, so in 2010, there would be no water savings associated with BMP 5. Assuming that this level of 2010 implementation was maintained in 2040, there would be no conservation savings associated with this BMP in 2040.

**Expanded (Double) Program:** In FY12, AWA assumed it would complete 4 surveys and then increase that to 6 in each of the following years through FY16. In the UWMP, AWA assumed water budgets would be created for half of the surveys conducted. It was then assumed that creating a water budget would reduce landscape water use by 10 percent. AWA estimated average water use per landscape account in 2010 to be 19.5 AFY, so conducting a landscape survey and creating a water budget would save 1.95 AFY. According to the LAFCO, the project landscape water use in the AWA service area in 2010 is the same in 2025. It was assumed that no additional increase in landscape water use would occur between 2025 and

2040. If AWA expanded BMP 2 and conducted and prepared twice as many surveys and water budgets, it would save 11.7 AFY (6 landscape water budgets at 1.95 AFY savings each).

Expanded (Quadruple) Program: If AWA doubled its expanded program in 2040, it would perform 12 water budgets (24 landscape surveys), resulting in a savings of 23.4 AFY.

In summary, the following water savings could be achieved:

- BMP 5, 2010 Water Savings Based on UWMP: 0 AFY
- BMP 5, 2040 Water Savings if Current Implementation Level is Maintained: 0 AFY
- BMP 5, 2040 Savings if Expanded (Double): 11.7 AFY
- BMP 5, 2040 Savings if Expanded (Quadruple): 23.4 AFY

#### 6. High-Efficiency Clothes Washing Machine Financial Incentive Programs

Current Program: AWA had not yet implemented this BMP at the time of its 2010 UWMP and did not budget for BMP 6 until FY12. Assuming that this level of 2010 implementation was maintained in 2040, there would be no conservation savings associated with this BMP in 2040. AWA intended to begin a rebate program in the Lake Camanche Village area initially, providing \$75 rebates for high-efficiency washing machines.

Expanded (Double) Program: In FY12, AWA planned to give 35 rebates, increasing the number of rebates to 70 rebates per year through FY16. Each rebate results in a savings of 0.025 AFY. As described in BMP 1, in 2040, it is estimated there will be 10,941 single family accounts and 52 multi-family accounts. If AWA provided rebates to 5 percent of these customers, it would provide 550 rebates, resulting in a water savings of 13.8 AFY.

Expanded (Quadruple) Program: If AWA doubled its expanded program in 2040, it would provide rebates to 10 percent of its single family and multi-family customers. This would result in 1,099 rebates and a savings of 27.5 AFY.

In summary, the following savings could be achieved:

- BMP 6, 2010 Water Savings Based on UWMP: 0 AFY
- BMP 6, 2040 Water Savings if Current Implementation Level is Maintained: 0 AFY
- BMP 6, 2040 Savings if Expanded (Double): 13.8 AFY
- BMP 6, 2040 Savings if Expanded (Quadruple): 27.5 AFY

#### 7. Public Information Programs

AWA promotes public awareness of water conservation through bill inserts, brochures, a demonstration garden, and special events throughout the year. It has and will continue to implement this BMP. CUWCC does not provide a methodology for quantifying water savings from this BMP.



## 8. School Education Programs

Historically, AWA provided presentation and demonstrations to schools and classes upon request. Per the 2010 UWMP, it plans to formalize its school education program, focusing on outreach to fifth graders (believed to be the age to best reach children and instill the importance of water conservation). AWA gives presentations to all fifth grade classes in its service area and provides students with low-flow showerheads and conservation tips. Water savings associated with the distribution of low-flow showerheads are captured in BMP 2. There is no method available from the CUWCC to quantify water savings from the other measures included in this BMP.

## 9. Conservation Programs for Commercial, Industrial, and Institutional Accounts

Current Program: According to the 2010 AWA UWMP, in 2010, AWA had about 389 CII accounts. It formalized this BMP in its UWMP and did not budget for it until FY12. Assuming that this level of 2010 implementation was maintained in 2040, there would be no conservation savings associated with this BMP in 2040.

Expanded (Double) Program: AWA estimated average water use of 4 AFY per CII account and a 5 percent water savings per survey conducted (0.20 AFY savings per survey). In FY12, it assumed it would conduct 10 CII surveys, increasing to a total of 30 surveys per year. Based on population increases and the percent of CII accounts in 2010, in 2040, AWA will have a service area population of 44,395 and 616 CII accounts. If AWA could conduct surveys for 8.4 percent of CII accounts (equivalent to 52 in 2040), it would achieve a water savings of 10.4 AFY.

Expanded (Quadruple) Program: If AWA doubled its expanded program in 2040, it would conduct surveys for 16.9 percent of CII accounts. This would result in 104 surveys and a savings of 20.8 AFY.

In summary, implementation of BMP 9 results in the following:

- BMP 9, 2010 Water Savings Based on UWMP: 0 AFY
- BMP 9, 2040 Water Savings if Current Implementation Level is Maintained: 0 AFY
- BMP 9, 2040 Savings if Expanded (Double): 10.4 AFY
- BMP 9, 2040 Savings if Expanded (Quadruple): 20.8 AFY

## 10. Wholesale Agency Assistance Programs

AWA offers the same conservation measures to all customers, including wholesale customers – Jackson, Plymouth, Drytown Community Services District (CSD), Pine Grove CSD, Rabb Park CSD, and Mace Meadows. AWA provides surveys, prepares water budgets, and provides residential and industrial rebates to its wholesale customers. Water savings have not been quantified since detailed information on customer water use patterns before and after BMP implementation is not available.

### 11. Retail Conservation Pricing

AWA uses a tiered water rate structure for water service rates in a portion of its service area. It will continue to charge volumetric pricing and expand this practice to the rest of its service area.

### 12. Conservation Coordinator

The Agency's Conservation Coordinator retired and the position has not yet been filled due to budget constraints. AWA plans to appoint a replacement Conservation Coordinator staffed at half-time. It is anticipated that when this position is filled, additional water savings will be achieved, however, CUWCC has not identified a method to quantify savings from this BMP.

### 13. Water Waste Prohibition

AWA adopted a water conservation policy that supports local ordinance that prohibits water waste. In addition, it will consider the development and adoption of a water waste ordinance, a year-round policy that prohibits overwatering landscape, system leaks, and open hoses for example. Potential water savings from this BMP have not been quantified since detailed information on customer water use patterns before and after BMP implementation is not available.

### 14. Residential Ultra-Low-Flow Toilet Replacement Programs

Current Program: AWA began offering rebates for ULFT to customers in the Lake Camanche Village area as a pilot program. Assuming 30 rebates are offered each year in Lake Camanche Village, a savings of 0.9 AFY could be achieved (equivalent to 0.029 AFY per toilet replaced, reaching 0.5 percent of the population). If AWA maintains these current levels of implementation and offers 30 rebates in 2040, AWA can expect to see the same 0.9 AFY in savings in 2040.

Expanded (Double) Program: As described in BMP 1, population is expected to increase to 44,395 in 2040, resulting in estimated single family accounts totaling 10,941 and multi-family accounts total 52. If AWA provided rebates to 1 percent of these customers in 2040, it would provide a total of 110 rebates, resulting in a water savings of 3.2 AFY.

Expanded (Quadruple) Program: If AWA doubled its expanded program in 2040, it would provide rebates for 2 percent of its customers in 2040. This would result in 104 surveys and a savings of 20.8 AFY.

In summary, implementation of BMP 14 results in the following:

- BMP 14, 2010 Water Savings Based on UWMP: 0.9 AFY
- BMP 14, 2040 Water Savings if Current Implementation Level is Maintained: 0.9 AFY
- BMP 14, 2040 Savings if Expanded (Double): 3.2 AFY
- BMP 14, 2040 Savings if Expanded (Quadruple): 6.4 AFY

### Maximum Theoretical Expanded Program (85 gpcd)

In 2020, AWA anticipates reaching a gpcd of 166. Assuming this gpcd in 2040, AWA would use 8,260.5 AFY in 2040, with an estimated 2040 population of 44,395. If AWA were to achieve 85 gpcd in 2040, it would use 4,229.8 AFY in 2040. This results in a maximum theoretical savings of 4,030.7 AFY.

## Calaveras County Water District

CCWD is a signatory to the CUWCC MOU and views conservation as an integral part of its water resources stewardship responsibility. As described in its 2010 UWMP, CCWD began implementing conservation BMPs, including leak detection and repair, 100 percent metered service, metered rates, public information programs, water waste prohibitions, and others, prior to signing the MOU. Current and planned implementation efforts for the fourteen CUWCC BMPs are described in CCWD's UWMP and briefly summarized in the following sections. CCWD has found that BMPs 1, 2, 5, 6, 9, and 14 are not locally cost-effective; it has therefore submitted exemption reports to the CUWCC for the 2008 to 2010 reporting period. Should funding be made available and these BMPs be implemented, additional water savings could be achieved.

### 1. Water Survey Programs for Single-Family Residential and Multi-Family Residential Customers

CCWD offers on-site surveys to customers upon request and monitors customer usage through metering. When customers with unusually high usage are identified, CCWD alerts these customers to the possibility of a water leak. If requested, a field service representative will visit the customer to perform a water usage analysis at no cost to the customer. Even though CCWD implements this BMP, it filed a cost exemption with CUWCC since implementing the BMP to CUWCC coverage is not cost effective. Based on the exemption report, CCWD assumes a 15 percent savings per customer per water survey which would result in 68 gpd per single family unit and 40 gpd per multi-family unit per survey conducted.

Current Program: While CCWD was implementing BMP 1 in 2010, due to the lack of data, it is assumed there was a 0 AFY water savings. Assuming that this level of 2010 implementation was maintained in 2040, there would be no conservation savings associated with this BMP in 2040.

Expanded (Double) Program: In the cost exemption report, CCWD assumed 180 single family surveys would be completed and 6 multi-family surveys would be completed (~1.5 percent of its customers), resulting in a water savings of 14 AFY. This is the value of water savings that could have been saved in 2010 with the implementation of an expanded program. If CCWD completed the same percentage of surveys for its single family and multi-family customers in 2040, it would conduct 379 single family surveys and 33 multi-family surveys, resulting in a cost savings of 30.3 AFY.

Expanded (Quadruple) Program: If CCWD doubled its expanded program in 2040, it would conduct 758 single family surveys and 60 multi-family surveys (multi-family surveys are capped at 60, as there are only 60 multi-family connections projected within the CCWD service area in 2040). This would result in a savings of 60.4 AFY in 2040.

In summary, the following water savings could be achieved:

- BMP 1, 2010 Water Savings Based on UWMP: 0 AFY
- BMP 1, 2040 Water Savings if Current Implementation Level is Maintained: 0 AFY
- BMP 1, 2040 Savings if Expanded (Double): 30.3 AFY
- BMP 1, 2040 Savings if Expanded (Quadruple): 60.4 AFY

## 2. Residential Plumbing Retrofit

CCWD offers “Living Wise” water conservation kits to all customers, free of charge. The kits include a low flow showerhead, low flow kitchen sink nozzle, bathroom faucet hot water saver fixture, a hot water temperature indicator gauge and a water use/energy cost calculation card and guide.

Current Program: Similar to BMP 1, although CCWD implements this BMP, it filed a cost exemption with CUWCC since implementation per the CUWCC annual implementation target would not be cost effective. CCWD will continue to make these kits available to customers upon request, but it could only expand the program with additional funding. Due to the lack of data, it is assumed there was a water savings of 0 AFY in 2010. Assuming that this level of 2010 implementation was maintained in 2040, there would be no conservation savings associated with this BMP in 2040.

Expanded (Double) Program: Based on the exemption report, CCWD assumes a 10 percent savings per customer per retrofit. This equates to a water savings of 45 gpd per single family retrofit and 30 gpd per multi-family retrofit. In its cost exemption report, CCWD assumes it could reach 4.9 percent of its single family customers and 63.6 percent of its multi-family customers. Assuming these implementation rates in 2040, CCWD would distribute 1,236 kits to single family customers and 38 kits to multi-family customers, resulting in a water savings of 63.6 AFY.

Expanded (Quadruple) Program: If CCWD doubled its expanded program in 2040, it would reach 9.8 percent of its single family customers and 100 percent of its multi-family customers, CCWD would distribute 2,471 kits to single family customers and all 60 of its multi-family customers, saving 126.6 AFY.

In summary, the following water savings could be achieved:

- BMP 2, 2010 Water Savings Based on UWMP: 0 AFY
- BMP 2, 2040 Water Savings if Current Implementation Level is Maintained: 0 AFY
- BMP 2, 2040 Savings if Expanded (Double): 63.6 AFY
- BMP 2, 2040 Savings if Expanded (Quadruple): 126.6 AFY

### 3. System Water Audits, Leak Detection and Repair

CCWD operations staff performs regular inspection and maintenance of water distribution systems as part of its leak detection and repair program. CCWD regularly tracks water loss in the system and attempts to repair leaks when funding is available. This BMP is fully implemented and ongoing. Leak detection and repair is a major element of CCWD's operations and maintenance budget. The amount spent each year, and water saved each year, depends on the extent of repair and replacement projects planned. Water savings have not been quantified since detailed information on CCWD leaks before and after BMP implementation is not available.

### 4. Metering with Commodity Rates for All New Connections and Retrofit of Existing Connections

CCWD meters all connection in its service area and bill bi-monthly using base rates plus volumetric charges. This BMP is fully implemented.

### 5. Large Landscape Conservation Programs and Incentives

Current Program: CCWD filed a cost exemption with CUWCC for this BMP since it determined implementation per the CUWCC annual implementation target would not be cost effective. Based on the cost exemption report, it has implemented 0 ETo-based water budgets, therefore, there was a 0 AFY cost savings in 2010. Assuming that this level of 2010 implementation was maintained in 2040, there would be no conservation savings associated with this BMP in 2040.

Expanded (Double) Program: If funding were available, CCWD could expand upon this program. Based on the exemption report, CCWD assumes a 15 percent water savings per year per customer receiving a budget or 0.35 AF/site for customers receiving an ETo-based landscape water budget. CCWD has approximately 100 metered connections dedicated for landscape in 2010. Based on the cost exemption report, CCWD assumed it would begin with 5 budgets per year (~5 percent of its dedicated landscape meters). In 2040, CCWD is projected to have 150 landscape customers. If it implemented budgets for the same percentage of customers in 2040 (5 percent), it would create 8 budgets and save 2.8 AFY.

Expanded (Quadruple) Program: If CCWD doubled its expanded program and created water budgets for 10 landscape customers (10 percent) in 2040, it would create 15 budgets and save 5.3 AFY.

In summary, the following water savings could be achieved:

- BMP 5, 2010 Water Savings Based on UWMP: 0 AFY
- BMP 5, 2040 Water Savings if Current Implementation Level is Maintained: 0 AFY
- BMP 5, 2040 Savings if Expanded: 2.8 AFY
- BMP 5, 2040 Savings if Double Expanded: 5.3 AFY

## 6. High-Efficiency Clothes Washing Machine Financial Incentive Programs

**Current Program:** This BMP was determined to not be cost effective, so it is not planned for implementation by CCWD. CCWD submitted an exemption report to CUWCC, therefore it assumed in 2010 there was a 0 AFY cost savings. Assuming that this level of 2010 implementation was maintained in 2040, there would be no conservation savings associated with this BMP in 2040.

**Expanded (Double) Program:** Based on the exemption report, CCWD estimates 5,250 gallons per year could be saved with the replacement of one high-efficiency clothes washer. CCWD's exemption report cites that it could provide rebates to 0.8 percent of the population. If CCWD provided rebates to 0.8 percent of its single family and multi-family population in 2040, it would distribute 203 rebates, resulting in a water savings of 3.3 AFY.

**Expanded (Quadruple) Program:** If CCWD doubled its expanded program in 2040, it would provide rebates to 1.6 percent of its single family and multi-family customers. This would result in 405 rebates and a savings of 6.5 AFY.

In summary, the following water savings could be achieved:

- BMP 6, 2010 Water Savings Based on UWMP: 0 AFY
- BMP 6, 2040 Water Savings if Current Implementation Level is Maintained: 0 AFY
- BMP 6, 2040 Savings if Expanded (Double): 3.3 AFY
- BMP 6, 2040 Savings if Expanded (Quadruple): 6.5 AFY

## 7. Public Information Programs

CCWD implements a public information program consisting of brochures and handouts, water conservation kits, public informational meetings, and other events. It also continuously updates its website which contains conservation tips and FAQs. CCWD has and will continue to implement this BMP. CUWCC has not identified a method for quantifying water savings from this BMP.

## 8. School Education Programs

CCWD has and will continue to implement various school education programs in its service area. For example, in January of every year, CCWD sponsors water awareness program to third graders in each of Calaveras County's ten schools, followed by a "Be a Water Saver" poster contest for the students. There is no method available from the CUWCC to quantify water savings from this BMP.

## 9. Conservation Programs for Commercial, Industrial, and Institutional Accounts

**Current Program:** CCWD implements an informal program for CII accounts by completing on-site water surveys upon request. It submitted a cost exemption report to CUWCC since it is not cost effective. If funding were available, it could expand upon its existing efforts for this BMP. Due to the lack of data, it is assumed there was a cost savings of 0 AFY in 2010.

Assuming that this level of 2010 implementation was maintained in 2040, there would be no conservation savings associated with this BMP in 2040.

Expanded (Double) Program: Based on the exemption report it assumes 200 gpd could be saved from one survey. If CCWD expanded BMP 9 in 2040 to the estimates indicated in the cost exemption report, it would conduct approximately 6 surveys per year (1 percent of CII customers), resulting in a cost savings of 1.3 AFY.

Expanded (Quadruple) Program: If CCWD doubled its expanded program in 2040, it would conduct surveys for 2 percent of CII accounts. This would result in 13 surveys and a savings of 2.9 AFY.

In summary, the following water savings could be achieved:

- BMP 9, 2010 Water Savings Based on UWMP: 0 AFY
- BMP 9, 2040 Water Savings if Current Implementation Level is Maintained: 0 AFY
- BMP 9, 2040 Savings if Expanded (Double): 1.3 AFY
- BMP 9, 2040 Savings if Expanded (Quadruple): 2.9 AFY

#### 10. Wholesale Agency Assistance Programs

CCWD is not a wholesale water supplier; therefore this BMP is not applicable. CCWD provided supplemental water to three private water companies that serve a total of 2,200 connections. It provides public information handouts and kits for distribution to the companies' customers.

#### 11. Retail Conservation Pricing

As described in BMP 4, CCWD meters all of its customers and uses a rate structure that includes a base rate and consumption charge. This BMP is fully implemented.

#### 12. Conservation Coordinator

CCWD designated a Conservation Coordinator in 2005 and has outlined specific duties for them to fulfill. CUWCC has not identified a method to quantify water savings from this BMP.

#### 13. Water Waste Prohibition

Article II, Section 16 of the CCWD Board Policy prohibits water waste. It also adopted Ordinance 2010-02, which updated the ordinance preventing water waste in July 2010. CUWCC has not identified a method to quantify water savings from this BMP.

#### 14. Residential Ultra-Low-Flow Toilet Replacement Programs

Current Program: This BMP is not cost effective for CCWD, so an exemption report was submitted to CUWCC. For the purposes of this analysis, it is assumed there was a 0 AFY water savings in 2010. Assuming that this level of 2010 implementation was maintained in 2040, there would be no conservation savings associated with this BMP in 2040.

Expanded (Double) Program: Should funding be available, CCWD could provide rebates to customers to encourage installation of low flow toilets (CCWD 2011). Based on the exemption report CCWD assumes installation of an ULFT would save 21.3 gpd in a single-family home and 51.1 gpd in a multi-family home. If, in 2010, CCWD expanded implementation of BMP 14 to the level indicated in its cost exemption report, it would distribute 1,200 ULFT rebates to single family customers. This assumes there were approximately 12,000 single family connections, 50% of which were pre-1992 and required toilet replacements (i.e. 6,000). It assumed 10% of the single family homes would receive 2 rebates each, for 2 toilets in their homes, resulting in 1,200 rebates distributed per year. If CCWD distributed 1,200 ULFT rebates every year, it would have fully implemented this BMP (by providing rebates to the 6,000 pre-1992 homes) by 2020. The potential savings associated with full implementation of this program us 1,283.7 AFY.

Expanded (Quadruple) Program: Because the program would already be fully implemented under the expanded (double) program, no additional savings is associated with this BMP.

In summary, the following water savings could be achieved:

- BMP 14, 2010 Water Savings Based on UWMP: 0 AFY
- BMP 14, 2040 Water Savings if Current Implementation Level is Maintained: 0 AFY
- BMP 14, 2040 Savings if Expanded (Double): 1,283.7 AFY
- BMP 14, 2040 Savings if Expanded (Quadruple): 1,283.7 AFY

Maximum Theoretical Expanded Program (85 gpcd)

In 2020, CCWD anticipates reaching a gpcd of 172. Assuming this gpcd in 2040, CCWD would use 10,096.4 AFY in 2040, with an estimated 2040 population of 52,369. If CCWD were to achieve 85 gpcd in 2040, it would use 4,989.5 AFY in 2040. This results in a maximum theoretical savings of 5,106.9 AFY.

## **The City of Stockton**

The City of Stockton meets its water demands from a combination of sources including wholesale treated surface water from SEWD, the Delta Water Supply Project (DWSP) (raw surface water from the San Joaquin River and the Mokelumne River), WID (surface water from the Mokelumne River), and groundwater. The City's current and projected water supplies are provided in Table B-4.



**Table B-4: Stockton Current and Project Water Supplies (AFY)\***

Source	2010	2015	2020	2025	2030	2035
SEWD Surface Water	29,780	17,500	17,500	17,500	17,500	17,500
DWSP Surface Water	0	33,600	33,600	33,600	33,600	33,600
WID Surface Water	0	6,500	6,500	13,000	13,000	13,000
Groundwater	5,475	23,114	23,114	23,114	23,114	23,114
Recycled Water	-	-	-	-	-	-
<b>Total</b>	<b>35,255</b>	<b>80,714</b>	<b>80,714</b>	<b>87,214</b>	<b>87,214</b>	<b>87,214</b>

Source: Stockton 2011.

\* Note that this table only shows available supply available to the City and are not necessarily equal to demands.

The City implements a robust water conservation program in its service area. All of the 14 BMPs are implemented in the City and briefly described in the following sections.

#### 1. Water Survey Programs for Single-Family Residential and Multi-Family Residential Customers

**Current Program:** Until May 2010, the City offered water use surveys for single and multi-family residential customers. Due to staff limitations, these complimentary surveys are no longer offered. Instead, the City is developing a self-performed water use survey. Therefore, it is assumed there was 0 AFY water savings in 2010. Assuming that this level of 2010 implementation was maintained in 2040, there would be no conservation savings associated with this BMP in 2040.

**Expanded (Double) Program:** As described in the City's 2010 UWMP, it currently does not have a means to quantify water savings for this BMP. Applying the same water savings assumptions used for AWA and CCWD (68 gpd for a single family survey and 40 gpd for a multi-family survey), if Stockton were to perform surveys for 1 percent of its single family and multi-family customers in 2040 (666 single family surveys and 78 multi-family surveys), it would achieve a water savings of 54.2 AFY.

Population growth is assumed in this calculation. Population was projected through 2035 in the Stockton 2010 UWMP. Assuming the population growth rate from 2035 to 2040 is the same as it was from 2030 to 2035, the population in 2040 would be 262,161 (see Table B-5). In 2010, single family customers accounted for 25.4 percent of the total population and multi-family customers accounted for 3.0 percent of the population. Applying these percentages to the 2040 population results in 66,591 single family accounts and 7,771 multi-family accounts in 2040.

**Table B-5: Population in City of Stockton Water Service Area**

<b>Year</b>	<b>Population</b>
<b>2010</b>	169,963
<b>2015</b>	183,247
<b>2020</b>	199,948
<b>2025</b>	216,038
<b>2030</b>	231,955
<b>2035</b>	246,596
<b>2040 (estimated)</b>	262,161

Expanded (Quadruple) Program: If Stockton doubled its expanded program in 2040, it would conduct surveys on 2% of its single family and multi-family customers. This is 1,332 single-family surveys and 155 multi-family surveys, which results in a savings of 108.4 AFY.

In summary, the following water savings could be achieved:

- BMP 1, 2010 Water Savings Based on UWMP: 0 AFY
- BMP 1, 2040 Water Savings if Current Implementation Level is Maintained: 0 AFY
- BMP 1, 2040 Savings if Expanded (Double): 54.2 AFY
- BMP 1, 2040 Savings if Expanded (Quadruple): 108.4 AFY

## 2. Residential Plumbing Retrofit

The City offers low-flow water use efficiency kits that include two 1.5 gpm low-flow showerheads, a 1.5 gpm kitchen aerator, two 1.0 gpm bathroom aerators, toilet flappers, and a metal garden hose nozzle. The City has been distributing kits since 1990 and began tracking the number of kits distributed in 2009.

Current Program: According to the City’s 2010 UWMP, in 2009 it distributed 467 kits and 595 kits in 2010. The City will continue to offer these kits. These kits are similar to those provided to customers by CCWD. Using the same assumptions, distribution of these kits equates to a water savings of 45 gpd per single family retrofit and 30 gpd per multi-family retrofit. As stated, in 2010, the City distributed 595 kits, resulting in a water savings of 25 AFY in 2010 (assuming an average water savings of 37.5 gpd per kit). Distributing kits to 595 customers is 1.2 percent of single family and multi-family accounts. Due to population growth, if the City distributed kits to 1.2 percent of its population in 2040, it would distribute 918 kits resulting in a water savings of 38.6 AFY.

Expanded (Double) Program: If Stockton expanded its current program to distribute kits to 2.5% of its single family and multi-family customers in 2040, the City would distribute 1,836 kits and save 77.1 AFY.

Expanded (Quadruple) Program: If Stockton doubled its expanded program, it would reach 4.9% of its customers, distributing 3,671 kits and saving 154.2 AFY.

In summary, the following water savings could be achieved:

- BMP 2, 2010 Water Savings Based on UWMP: 25.0 AFY
- BMP 2, 2040 Water Savings if Current Implementation Level is Maintained: 38.6 AFY
- BMP 2, 2040 Savings if Expanded (Double): 77.1 AFY
- BMP 2, 2040 Savings if Expanded (Quadruple): 154.2 AFY

### 3. System Water Audits, Leak Detection and Repair

The City implements an ongoing water audit program which has allowed them to maintain an average of 5.4 percent water loss from 2000 to 2010. The BMP is currently being fully implemented and will continue to be implemented as part of the City's ongoing O&M program.

### 4. Metering with Commodity Rates for All New Connections and Retrofit of Existing Connections

The City of Stockton service area is fully metered and all connections are billed based on the volume of water used; therefore, this BMP has been fully implemented.

### 5. Large Landscape Conservation Programs and Incentives

Current Program: While it does not currently have a formal Large Landscape Conservation Program, in 2010, the City of Stockton began implementing the State's Model Water Efficient Landscape Ordinance (MWEL0), finalized conversion of 12 of the newest City parks to computerized irrigation controls to achieve a water savings of approximately 25 percent, and launched a website offering water wise landscaping resources and tips. The City intends to develop water budgets for its largest landscape customers as part of a pilot program. Because no budgets were developed in 2010, it is assumed there was a water savings of 0 AFY. Assuming that this level of 2010 implementation was maintained in 2040, there would be no conservation savings associated with this BMP in 2040.

Expanded (Double) Program: According to the City's 2010 UWMP, this BMP is currently not quantifiable. The City has approximately 900 landscape-dedicated meters. Similar to the BMP 1 estimates, the number of landscape accounts in 2040 was estimated based on the population growth rate and 2010 percentage of landscape users. The estimated number of landscape customers in 2040 is 1,450. If the City offered this BMP to 1% of these customers, it would prepare 15 budgets resulting in a water savings of 5.3 AFY in 2040.

Expanded (Quadruple) Program: If Stockton doubled its expanded program, it would create water budgets for 29 landscape customers (2%) in 2040, saving 10.2 AFY.

In summary, the following water savings could be achieved:

- BMP 5, 2010 Water Savings Based on UWMP: 0 AFY
- BMP 5, 2040 Water Savings if Current Implementation Level is Maintained: 0 AFY
- BMP 5, 2040 Savings if Expanded (Double): 5.3 AFY
- BMP 5, 2040 Savings if Expanded (Quadruple): 10.2 AFY

#### 6. High-Efficiency Clothes Washing Machine Financial Incentive Programs

Current Program: In 2007 the City began offering \$150 rebates for high-efficiency clothes washers through the CUWCC SMART Rebate Program. According to the City's 2010 UWMP, each installation is assumed to save 0.314 AF. The City provided 311 rebates from 2007 to 2010. Assuming the City provided the same number of rebates each year from 2007 to 2010, then it provided 78 rebates each year. If the City provided 78 rebates in 2010, it saved 24.5 AFY of water. Providing 78 rebates to its single family customers is equivalent to providing rebates to 0.2% of its single family customers. If the City continued providing rebates to 0.2% of its single-family customers in 2040, it would provide 133 rebates and save 41.8 AFY in 2040.

Expanded (Double) Program: If the City doubled current implementation levels and provided rebates to 0.4% percent of its single family customers, it would provide 266 rebates in 2040, resulting in a water savings of 83.5 AFY.

Expanded (Quadruple) Program: If the City quadrupled current implementation levels and provided rebates to 0.8% percent of its single family customers, it would provide 533 rebates in 2040, resulting in a water savings of 167.4 AFY.

In summary, the following water savings could be achieved:

- BMP 6, 2010 Water Savings Based on UWMP: 24.5 AFY
- BMP 6, 2040 Water Savings if Current Implementation Level is Maintained: 41.8 AFY
- BMP 6, 2040 Savings if Expanded (Double): 83.5 AFY
- BMP 6, 2040 Savings if Expanded (Quadruple): 167.4 AFY

#### 7. Public Information Programs

Public information regarding water conservation is performed through the City's outreach program. Measures include monthly bill inserts, public outreach events, print and web-based publications, and annual updates. CUWCC has not identified a method to quantify water savings from this BMP.

#### 8. School Education Programs

The City provides water conservation school education through the Stockton Area Water Suppliers (SAWS), comprised of the City of Stockton, SEWD, California American Water Company, and San Joaquin County. SAWS provides teachers at public and private schools

packets of water conservation materials that can be discussed during class programs. The City plans to continue to participate in this program. CUWCC has not identified a method to quantify water savings from this BMP.

#### 9. Conservation Programs for Commercial, Industrial, and Institutional Accounts

Current Program: The City offers a high efficiency toilet (HET) Direct Install Program for its CII customers. The program covers the cost of the installation and hardware. The City has installed 269 toilets since it started implementing this BMP in 2010 resulting in a water savings of 252.9 AFY (or 0.94 AFY / toilet replacement). If the City continued installing toilets in 2040 at the same rate (16.5%) that it did in 2010, the City could save 390.1 AFY in 2040. The City also makes periodic visits to CII customers to conduct water use evaluations.

Expanded (Double) Program: If Stockton doubled its current program, it would provide installs for 33% of its CII customers in 2040. CII accounts in 2040 were estimated using the same approach as the single family, multi-family, and landscape accounts (based on population growth rate and percentage of 2010 accounts to total population). If Stockton provided installs for 33% of its CII customers, it would provide 830 installs and save 780.2 AFY.

Expanded (Quadruple) Program: If Stockton quadrupled its current program, it would provide installs for 66% of its CII customers in 2040, which would result in 1,660 installs and a savings of 1,560.4 AFY.

In summary, the following water savings could be achieved:

- BMP 9, 2010 Water Savings Based on UWMP: 252.9 AFY
- BMP 9, 2040 Water Savings if Current Implementation Level is Maintained: 390.1 AFY
- BMP 9, 2040 Savings if Expanded (Double): 780.2 AFY
- BMP 9, 2040 Savings if Expanded (Quadruple): 1,560.4 AFY

#### 10. Wholesale Agency Assistance Programs

The City of Stockton meets with California American Water Company, San Joaquin County, and SEWD (all members of SAWS) once a month to discuss water-related matters including supply and conservation. There is no method identified by the CUWCC to quantify water savings from this BMP.

#### 11. Retail Conservation Pricing

The City has a fee schedule with a uniform rate schedule. The City's water conservation ordinance allows the City to raise rates during declared water emergencies. Potential water savings from this BMP have not been quantified since detailed information on customer water use patterns before and after BMP implementation is not available.

## 12. Conservation Coordinator

The City's Water Resources Program Manager acts as the Water Conservation Coordinator. The BMP is in place and the City will continue to implement it. As such, this BMP is fully implemented.

## 13. Water Waste Prohibition

Chapter 13.28 of the City's Municipal Code restricts certain uses of water which is enforceable per the Code. This BMP is fully implemented.

## 14. Residential Ultra-Low-Flow Toilet Replacement Programs

Current Program: Since 2007, the City has offered up to \$100 rebates for ULFTs through the CUWCC SMART Rebate Program. The City has issued 137 rebates to date. Assuming it provided the same number of rebates each year from 2007 to 2010, it provided 34 rebates per year. Based on the City's 2010 UWMP, it is assumed each ULFT installation saves 0.56 AF. Therefore, in 2010, if the City provided 34 ULFT rebates, a water savings of 19.0 AFY was achieved. Providing 34 rebates in 2010 is equivalent to providing rebates to 0.1% of its single family customers. If the City continued offering rebates in 2040 at this same level, the City could save 29.4 AFY in 2040.

Expanded (Double) Program: If the City expanded implementation of BMP 14 and provided rebates to 0.2% of its single family customers (149 rebates), it would save 83.3 AFY of water in 2040.

Expanded (Quadruple) Program: If the City quadrupled its current program and provided rebates to 0.4% of its single family customers (297 rebates), it would save 166.6 AFY of water in 2040.

In summary, the following water savings could be achieved:

- BMP 14, 2010 Water Savings Based on UWMP: 19.0 AFY
- BMP 14, 2040 Water Savings if Current Implementation Level is Maintained: 29.4 AFY
- BMP 14, 2040 Savings if Expanded (Double): 83.3 AFY
- BMP 14, 2040 Savings if Expanded (Quadruple): 166.6 AFY

Maximum Theoretical Expanded Program (85 gpcd)

In 2020, the City of Stockton anticipates reaching a gpcd of 165. Assuming this gpcd in 2040, the City of Stockton would use 48,485.8 AFY in 2040, with an estimated 2040 population of 262,161. If the City were to achieve 85 gpcd in 2040, the City would use 24,977.5 AFY in 2040. This results in a maximum theoretical savings of 23,508.2 AFY.

## The City of Lodi

The City of Lodi is committed to water conservation and has implemented several policies and ongoing programs to promote and encourage water conservation. It has also implemented several drought-specific programs that take effect when water supplies become limited. The City's current water conservation program consists primarily of outdoor watering restrictions. As described in the City's 2010 UWMP, benefit-cost (B/C) ratios were developed for each of the fourteen BMPs. B/C ratios of less than one were not considered to be financially beneficial and were not recommended for implementation. The status of implementation of each BMPs, and the B/C ratio of each BMP not being implemented, are provided in Table B-6.

**Table B-6: City of Lodi's BMPs**

<b>BMP</b>	<b>City Measure</b>	<b>Compliance with UWMP Act</b>
1. Water Survey Programs for Single-Family Residential and Multi-Family Residential Customers	None at this time	B/C = 0.9
2. Residential Plumbing Retrofit	Rebates offered at time of purchase for water savings device	Yes
3. System Water Audits, Leak Detection and Repair	Goal to replace 1% of pipeline system annually	Yes
4. Metering with Commodity Rates for All New Connections and Retrofit of Existing Connections	Residential Water Meter Program underway; majority of commercial, industrial, landscape connections metered	In Progress
5. Large Landscape Conservation Programs and Incentives	None at this time; Water conservation Ordinance applies to large landscape	B/C Ratio = 5.6
6. High-Efficiency Clothes Washing Machine Financial Incentive Programs	None at this time	B/C Ratio = 0.7
7. Public Information Programs	Conservation information included in bill inserts, newsletters, brochures, demonstration gardens, special events, website	Yes

**Table B-6: City of Lodi's BMPs**

<b>BMP</b>	<b>City Measure</b>	<b>Compliance with UWMP Act</b>
8. School Education Programs	K-6 classroom presentations (currently suspended until full-time Water Conservation Coordinator position filled)	Yes
9. Conservation Programs for Commercial, Industrial, and Institutional (CII) Accounts	Water surveys not offered at this time; ULFT replacement program is available to CII accounts	B/C Ratio = 2.2
10. Wholesale Agency Assistance Programs	Not applicable	Not applicable
11. Retail Conservation Pricing	Residential Water Meter Program will allow for conservation pricing	In Progress
12. Conservation Coordinator	Position is currently vacant; part-time employees fulfill similar water conservation enforcement duties	Yes
13. Water Waste Prohibition	Restriction and penalties in place and enforced for wasted water; emergency conservation measures in place for emergency conditions	Yes
14. Residential Ultra-Low-Flow Toilet (ULFT) Replacement Programs	Rebates offered at the time of purchase for ULFTs	Yes

Source: RMC 2011

The BMPs and estimated water savings are briefly summarized in the following sections.

1. Water Survey Programs for Single-Family Residential and Multi-Family Residential Customers

Water surveys would consist of residential indoor and outdoor water use reviews resulting in staff recommendations for water savings.

Current Program: The City does not currently have a residential water survey program in place and does not plan to implement one. Therefore, water savings in 2010 from BMP 1 was 0 AFY. Assuming that this level of 2010 implementation was maintained in 2040, there would be no conservation savings associated with this BMP in 2040.



**Expanded (Double) Program:** Based on the City’s 2010 UWMP, it assumes each survey conducted would save 0.032 AFY<sup>1</sup>. Population was projected through 2035 in the City’s 2010 UWMP, as shown in Table B-7. Assuming the population growth rate from 2035 to 2040 is the same as it was from 2030 to 2035 (5.1 percent), the population in 2040 would be 85,654. Single family customers account for 26.2% of the total population in 2010 and multi-family users account for 8.9% of population. Using the same percentages, based on a population of 85,654, there would be 22,454 single family users and 7,652 multi-family users.

**Table B-7: Population in the City of Lodi Service Area**

<b>Year</b>	<b>Population</b>
<b>2010</b>	63,549
<b>2015</b>	66,791
<b>2020</b>	70,198
<b>2025</b>	73,778
<b>2030</b>	77,542
<b>2035</b>	81,497
<b>2040 (estimated)</b>	85,654

If the City conducted surveys for 1% of its single family and multi-family customers in 2040, it would conduct 301 surveys, resulting in a water savings of 9.6 AFY.

**Expanded (Quadruple) Program:** In the double expanded program, Lodi would conduct surveys on 2% of its single family and multi-family customers. In 2040, it would conduct 602 surveys, resulting in a savings of 19.3 AFY.

In summary, the following water savings could be achieved:

- BMP 1, 2010 Water Savings Based on UWMP: 0 AFY
- BMP 1, 2040 Water Savings if Current Implementation Level is Maintained: 0 AFY
- BMP 1, 2040 Savings if Expanded (Double): 9.6 AFY
- BMP 1, 2040 Savings if Expanded (Quadruple): 19.3 AFY

<sup>1</sup> Water savings can vary widely depending on the individual customer’s implementation of recommendations. The CUWCC estimates that outdoor water use could be decreased by 10 percent for each unit surveyed.

## 2. Residential Plumbing Retrofit

The City promotes retrofitting residential plumbing fixtures through a rebate program. Rebates of 50 percent of the cost of the low-flow device are provided at the store at the time of purchase. The City then reimburses the store the cost of the rebate. The number of rebates provided since 2005 has significantly decreased due to the economic downturn and because two of the stores that were carrying the rebates went out of business or stopped participating in the program. The City expects more rebates to be distributed as the economy recovers.

Current Program: In 2010, no low flow showerhead, hose bib timer, or hot water heater blanket rebates were distributed, resulting in a water savings of 0 AFY. Assuming that this level of 2010 implementation was maintained in 2040, there would be no conservation savings associated with this BMP in 2040. Applying the CUWCC assumption that a low-flow showerhead retrofit will save 2.9 gpcd on post-1980 constructed homes and 7.2 gpcd on pre-1980 constructed homes, the City estimates a 0.2 AFY savings if 10 low flow showerhead, 5 hose bib timer, and 5 hot water heater blanket rebates are distributed. They assumed this number of rebates would be provided each year from 2011 through 2015.

Expanded (Double) Program: If BMP 2 is expanded and rebates are provided to 1% of the City's single family and multi-family customers, a water savings of 13.9 AFY would be achieved in 2040 (225 rebates for single family users and 77 rebates to multi-family users).

Expanded (Quadruple) Program: If Lodi doubled its expanded program, it would reach 2% of its customers, providing 449 rebates to single family customers and 153 rebates to multi-family customers. This would result in a savings of 27.8 AFY in 2040.

In summary, the following water savings could be achieved:

- BMP 2, 2010 Water Savings Based on UWMP: 0 AFY
- BMP 2, 2040 Water Savings if Current Implementation Level is Maintained: 0 AFY
- BMP 2, 2040 Savings if Expanded (Double): 13.9 AFY
- BMP 2, 2040 Savings if Expanded (Quadruple): 27.8 AFY

## 3. System Water Audits, Leak Detection and Repair

The City implements a capital improvement program with a goal of replacing 1 percent of the pipeline system annually. The City plans to survey and replace 5,000 feet of water main every year from 2011 through 2015 resulting in water savings ranging from 163 AFY to 178 AFY. According to the City's 2010 UWMP, water savings in 2010 was not quantified due to the lack of data. It would be possible to further expand this BMP and save additional water if pipeline replacement increased; due to limited information about the savings expected from program scaling, this is unable to be estimated at this time.

4. Metering with Commodity Rates for All New Connections and Retrofit of Existing Connections

The City meters and bills for actual water use for most CII accounts and landscape customers. The City plans to install water meters for unmetered commercial accounts upon completion of its Residential Water Meter Program. Through the Residential Water Meter Program, customers with existing meters are converted to usage-based rates.

**Current Program:** This BMP is not being currently implemented. As such, there is assumed to be no savings associated with this BMP in 2010. The City’s plan for implementation is provided in Table B-8. The City estimates all single family customers will be converted to usage-based water rates by January 2019. As such, the program is assumed to be fully implemented by 2040. Assuming Lodi meters the 6,649 unmetered accounts remaining in 2015 by the end of the program (and thus, by 2040), 316 AF will be saved (0.05 AFY savings per retrofit). This assumes 0.05 AF in savings per retrofit. This means that a total of 730.1 AF will be saved by 2040 (414 anticipated savings by 2015 and 316 AF achieved through full implementation).

**Table B-8: City of Lodi BMP 4 Implementation**

	2011	2012	2013	2014	2015
Unmetered Accounts	17,009	13,336	10,660	8,605	6,649
Retrofit Meters Installed	3,071	2,073	1,453	1,354	874
Accounts without Commodity Rates	19,685	19,685	17,462	13,793	11,123
Accounts with Commodity Rates	2,874	3,100	5,551	9,449	12,353
Water Savings (AFY)	146	158	255	347	414

**Expanded (Double) Program:** In 2040, this BMP will be fully implemented because this program is expected to be completed by January 2019 and is already anticipated to be fully implemented under the current program. Thus, no additional savings would be achieved under a double expanded program in 2040.

**Expanded (Quadruple) Program:** In 2040, this BMP will be fully implemented because this program is expected to be completed by January 2019 and is already anticipated to be fully implemented under the current program. Thus, no additional savings would be achieved under a quadruple expanded program in 2040.

In summary, the following water savings could be achieved:

- BMP 4, 2010 Water Savings Based on UWMP: 0 AFY
- BMP 4, 2040 Water Savings if Current Implementation Level is Maintained: 730.1 AFY

- BMP 4, 2040 Savings if Expanded (Double): 730.1 AFY
- BMP 4, 2040 Savings if Expanded (Quadruple): 730.1 AFY

#### 5. Large Landscape Conservation Programs and Incentives

Current Program: The City installed “Maxicom” irrigation controllers and telecommunications equipment to better manage its park irrigation. The City does not currently budget for this BMP due to staff shortages and the priority of the water meter program; however, because the B/C ratio of this BMP is 5.6, the City will consider implementing it in the future. Because implementation of BMP 5 had not yet begun, it is assumed there was a 0 AFY water savings in 2010. If that the level of implementation was maintained from 2010 to 2040, there would be no conservation savings associated with this BMP in 2040.

Expanded (Double) Program: Assuming a 15 percent reduction in water use after a survey is completed, an estimated 12 AFY could be saved if 10 surveys were conducted, or 1.2 AFY per survey, according to the City’s 2010 UWMP. Based on population projections and the percent of landscape customers in 2010, there would be 31 landscape customers in 2040. If the City conducts surveys for 5% of its 31 landscape customers in 2040, it would save 2.4 AFY.

Expanded (Quadruple) Program: If the City doubles its expanded double program, it would conduct surveys for 10% of its 31 landscape customers in 2040. This would result in savings of 4.8 AFY.

In summary, the following water savings could be achieved:

- BMP 5, 2010 Water Savings Based on UWMP: 0 AFY
- BMP 5, 2040 Water Savings if Current Implementation Level is Maintained: 0 AFY
- BMP 5 2040 Savings if Expanded (Double): 2.4 AFY
- BMP 5 2040 Savings if Expanded (Quadruple): 4.8 AFY

#### 6. High-Efficiency Clothes Washing Machine Financial Incentive Programs

Current Program: The City does not currently implement this BMP because it was not determined to be cost effective, therefore there was no associated water savings with this BMP in 2010. Assuming that this level of 2010 implementation was maintained in 2040, there would be no conservation savings associated with this BMP in 2040.

Expanded (Double) Program: If the City implements this BMP in 2040 and provides \$75 rebates for high-efficiency washing machines to its single family and multi-family customers, 5,100 gallons per year would be saved per rebate. If the City provided rebates to 1% of its single family and multi-family customers in 2040, the City would provide 301 rebates and save 4.7 AFY.

**Expanded (Quadruple) Program:** If the City doubles its double expanded program, it would provide rebates to 2% of its single family and multi-family customers in 2040. This would result in 602 rebates and savings of 9.4 AFY.

In summary, the following water savings could be achieved:

- BMP 6, 2010 Water Savings Based on UWMP: 0 AFY
- BMP 6, 2040 Water Savings if Current Implementation Level is Maintained: 0 AFY
- BMP 6, 2040 Savings if Expanded (Double): 4.7 AFY
- BMP 6, 2040 Savings if Expanded (Quadruple): 9.4 AFY

## 7. Public Information Programs

The City has an ongoing public information program which began in 1977. CUWCC has not determined a method to estimate savings from this BMP; however, the City believes this Program is beneficial and will continue to implement it. Because CUWCC has not identified methodology for estimating potential savings, savings have not been projected for implementation of the BMP.

## 8. School Education Programs

In 1986 the City began its Water Educational Program in Lodi elementary schools. The program focuses on grades kindergarten through six because those are believed to be the most effective grades for cultivating water awareness and the formation of good water habits. There is no method available to quantify water savings from the program. The City has fully implemented this program and will continue implementing this BMP.

## 9. Conservation Programs for Commercial, Industrial, and Institutional Accounts

**Current Program:** The City's conservation program applies to all customers, including CII accounts, however, the City plans to implement a water use survey program specifically for CII accounts when staffing and priorities allow. Because no surveys were conducted in 2010 for CII accounts, it is assumed there was a 0 AFY water savings. Assuming that this level of 2010 implementation was maintained in 2040, there would be no conservation savings associated with this BMP in 2040.

**Expanded (Double) Program:** Based on the 2010 UWMP, a water use survey for a CII account would save an average of 1.5 AFY. If the City expands implementation of BMP 9 and conducts surveys for 1 percent of its CII customers in 2040 (179 surveys), it could achieve a water savings of 262.2 AFY.

**Expanded (Quadruple) Program:** If the City doubles implementation of its double expanded program, it would conduct surveys for 2 percent of its CII customers in 2040. This would result in 358 surveys and 524.5 AFY of water savings.

In summary, the following water savings could be achieved:

- BMP 9, 2010 Water Savings Based on UWMP: 0 AFY
- BMP 9, 2040 Water Savings if Current Implementation Level is Maintained: 0 AFY
- BMP 9, 2040 Savings if Expanded (Double): 262.2 AFY
- BMP 9, 2040 Savings if Expanded (Quadruple): 524.5 AFY

#### 10. Wholesale Agency Assistance Programs

The City is not a wholesale water agency so this BMP is not applicable. The City does not currently budget for a program specific to CII and does not intend to. Since the B/C ratio is greater than 1, it will consider future implementation. Assuming the City surveys 10 percent of its CII accounts over an 8 year period, 138 surveys would be conducted resulting in a potential water savings of 44 AFY.

#### 11. Retail Conservation Pricing

The City is in the process of implementing its Residential Water Meter Program. Water meters will be installed between 2011 and 2019. As meters are installed it will apply commodity pricing (see BMP 4). The City has developed a tiered rate structure for single family residential accounts with escalating rates for customers that use more water, encouraging water conservation. Water savings from this BMP are factored into the water savings described in BMP 4. Because this BMP is planned to be fully implemented, additional savings are not projected for this BMP.

#### 12. Conservation Coordinator

The City's Water Conservation Coordinator position is not currently filled. Several City staff members work part-time to perform many of the same duties. CUWCC does not have a method for quantifying water savings from this BMP.

#### 13. Water Waste Prohibition

The City has an existing Water Conservation Ordinance that defines water waste prohibitions for its customers. This BMP was implemented in 1977 and will continue to be enforced in the future. Because this BMP is fully implemented, additional water savings from this BMP are not anticipated.

#### 14. Residential Ultra-Low-Flow Toilet Replacement Programs

Current Program: The City's Building Code requires all new residential construction and major remodels/renovations of existing homes to install low-flow fixtures. A rebate program (as described in BMP 2) is implemented by the City to encourage the installation of ULFTs. The installation of ULFTs is estimated to save 1.9 gallons per flush or 0.03 AFY per rebate. In 2010 the City provided 1 ULFT rebate resulting in a water savings of 0.03 AFY. Assuming this same level of implementation in 2040, the City could expect to have the same savings of 0.03 AFY in 2040.

Expanded (Double) Program: If the City expands the program and provides rebates to 1% of its estimated 30,106 single family and multi-family customers in 2040, it would provide 301 rebates and achieve water savings of 8.8 AFY.

Expanded (Quadruple) Program: If the City doubles its double expanded program and provides rebates to 2% of its single family and multi-family customers in 2040, it would provide 602 rebates and achieve water savings of 17.7 AFY.

In summary, the following water savings could be achieved:

- BMP 14, 2010 Water Savings Based on UWMP: 0.03 AFY
- BMP 14, 2040 Water Savings if Current Implementation Level is Maintained: 0.03 AFY
- BMP 14, 2040 Savings if Expanded (Double): 8.8 AFY
- BMP 14, 2040 Savings if Expanded (Quadruple): 17.7 AFY

Maximum Theoretical Expanded Program (85 gpcd)

In 2020, the City of Lodi anticipates reaching a gpcd of 199. Assuming this gpcd in 2040, Lodi would use 19,105.68 AFY in 2040, with an estimated 2040 population of 85,654. If the City were to achieve 85 gpcd in 2040, the City would use 8,160.7 AFY in 2040. This results in a maximum theoretical savings of 10,945.0 AFY.

## **Woodbridge Irrigation District**

WID diverts water from the Mokelumne River and the Delta to supply water to its customers. Landowners in the WID service area also pump groundwater for approximately 26,000 acres not serviced directly by the canal system. At one time WID's diversions from the Mokelumne River exceeded 100,000 AFY. Over the years they have decreased to 60,000 AFY. Its base supply of 60,000 AFY is to be released by EBMUD as part of its 1938 and 1965 settlement agreements. WID has taken an additional 12,000 AFY in the past per additional water rights, bringing its total base supply in wet years to an average of 72,000 AFY. WID is further reduced in dry years when entitlements are reduced by provisions in its agreements with EBMUD.

In order to comply with the Water Conservation Act of 2009, WID prepared a 2014 AWMP. WID also measures the volume of water delivered to customers and has a pricing structure for customers based on quantity delivered, as required by the Act. Some of the additional water conservation measures it has implemented in recent years are described in the following sections.

### Farm Gate Meters, Metering and Volumetric Pricing System

WID meters all water diversions on a volumetric basis at the point of use. A metering technician at WID keeps accurate records and monitors farm gate meters on a daily basis and Micrometer meters on a monthly basis. Growers pay a base rate to WID when they sign up to receive water. If a grower uses more water than was included in the base rate, they

pay additional charges for the excess water used. If they use less water than was included in the base rate, they are eligible for a refund.

#### Municipal Water Meters

Municipalities served by WID, including Lodi and Stockton, receive water on a bulk basis and are required to meter supplies. WID uses a Supervisory Control and Data Acquisition (SCADA) system which shows the flow rate and total flow for each city.

#### Automated Canal Gate Structures

WID invested in an automated SCADA control system to operate its diversion dam, fish screen, and canal gate control system. The SCADA system has saved water, reduced labor costs, and provides reliable and accurate control of reservoir water levels and downstream flows in the Mokelumne River and the District's canal system.

#### Drip Irrigation System

WID provides growers with advice and consultation on the design of drip irrigation systems to help maximize water and power efficiency.

WID recently implemented a drip irrigation conversion program. Through this program, WID has made available 6,000 AFY of Mokelumne River supply to the City of Lodi at a cost of \$200/AF. The funds secured from this transfer were used to fund the Woodbridge Diversion Dam replacement.

#### Strict Water Conservation Rules

Rules that restrict waste of water are included in WID's Rules and Regulations are strictly enforced. For example, if a grower intentionally spills irrigation water, that grower may lose a turn in line or be denied service. Growers can also be denied water service for failing to maintain and clean their ditches.

#### Weed Control and Canal Maintenance

Weeds and overgrowth in canals restrict water flows and their roots can perforate canal walls, resulting in leakage and water consumption. WID employs a trained vegetation control manager who implements a weed control program. The canal is also inspected for leaks and maintained accordingly.

#### Zero Spillage Requirement

WID operates the canal such that the amount of water in the canal equals the demand for water. Spills at the end of the system are monitored. The ditch tenders operate the canals to maximize efficiency and save water (WID 2013).



## **North San Joaquin Water Conservation District**

As a California Water Conservation District, NSJWCD has the power to impose groundwater charges, form improvement districts to fund projects, and sell surface water. NSJWCD serves approximately 154,000 acres, 4,740 acres of which are within the Lodi city limits and 5,600 acres within Lodi's sphere of influence. It operates two pump stations on the Mokelumne River. In 1996, NSJWCD adopted a Groundwater Management Plan (GWMP) meeting requirements of Assembly Bill 3030 (AB3030) to address declining groundwater levels. Actions to address the groundwater quality and quantity issues included securing a surface water supply and implementing efficient water application methods. NSJWCD has access to 20,000 AFY of Mokelumne River water (permit 10477 – a post-1914 appropriative right) when certain criteria are met.

## **Appendix C: MOCASIM for the MokeWISE Program Technical Memorandum**

Appendix C provides the MOCASIM for the MokeWISE Program Technical Memorandum, which further describes the MOCASIM model.

Preliminary Draft  
Technical Memorandum

---

**MOCASIM**  
**for the MokeWISE Program**

---

Prepared for:

**Upper Mokelumne River Watershed Authority**

Prepared by:

**Avry Dotan, AD Consultants**

**November 2013**

## Contents

1	Purpose.....	4
2	Model Background.....	4
3	Geographical Areas.....	5
3.1	Upper Mokelumne System.....	5
3.1.1	Lodi Decree.....	8
3.1.2	Instream flow requirements.....	9
3.1.3	Upper Mokelumne System Operation.....	11
3.1.4	Power plants operation.....	11
3.1.5	Test run.....	12
3.2	Lower Mokelumne System.....	13
3.2.1	Upstream Diversion.....	14
3.2.2	EBMUD Water Supply System.....	15
3.2.3	Flood Control Operation.....	17
3.2.4	Lower Mokelumne Watershed.....	18
3.2.5	Freeport Project (American River Import).....	20
4	Hydrology and Simulation Period.....	20
5	System Operation.....	23
5.1	Non-Appropriated Water.....	25
5.2	Virtual Storage Concept.....	25
5.3	Groundwater Banking (GWB).....	28
6	Conclusion.....	28

## Figures

Figure 1 - Upper Mokelumne System.....	6
Figure 2 - Upper Mokelumne Reservoirs and Power Plants.....	7
Figure 3 - Lodi Decree .....	8
Figure 4 - FERC Instream Flow Requirements in CFS .....	10
Figure 5 - FERC Pulse Flow Requirements in CFS.....	11
Figure 6 - Test Run for Energy Production.....	12
Figure 7 - MOCASIM Logical Overview.....	13
Figure 8 - Annual Upstream Diversions .....	14
Figure 9 - Percent Distribution of Annual Diversion to Upstream Users .....	15
Figure 10 - EBMUD Early Deficiency Rules .....	16
Figure 11 - Flood Control Diagram .....	17
Figure 12 - Annual Downstream Diversions.....	18
Figure 13 - Percent Distribution of Annual Diversion to Downstream Users .....	19
Figure 14 - Fish Release Requirements in CFS .....	19
Figure 15 - Channel Losses on the Lower Mokelumne as function of Camanche Release .....	20
Figure 17 - MOCASIM Hydrology.....	22
Figure 18 - Hydrological Monitoring Stations in the Mokelumne River Basin.....	23
Figure 19 - Example for Prior Rights Diversion under Pre and Post Project.....	24
Figure 20 - Illustration of VS Concepts in Pardee Reservoir.....	27
Figure 21 - GWB Diversion along the Lower Mokelumne .....	28

---

# MOCASIM for MokeWISE

---

## 1 Purpose

Utilize MOCASIM to perform water availability analysis and then quantify the potential benefits and impacts to the study partners and other water users in the Mokelumne basin resulting from proposed water supply projects identified in the MokeWISE Program.

## 2 Model Background

MOCASIM is a reservoir operations model designed to simulate water storage and diversion operations on the Mokelumne River. MOCASIM is capable of analyzing various operating strategies of Pardee and Camanche reservoirs on the Mokelumne River, assessing water availability to serve EBMUD; Amador, Calaveras and San Joaquin counties; and then simulating newly proposed storage and diversion alternatives for beneficial use. MOCASIM also incorporates imports from water supply developments in the American and Calaveras River Watersheds.

MOCASIM is a mass-balance simulation model. It uses either monthly or daily time-step (depending on the geographical area, as explained below) for the hydrologic period beginning in 1953 through 2010. Senior appropriations, fishery flows, and hydropower releases are based on historical and/or future levels of development in the basin, water rights and agreements, and reservoir operating rules.

The model was developed by AD Consultants in 2007 for the Mokelumne River Water and Power Authority (MRW&PA) and has been maintained and upgraded by AD Consultants ever since. The original version of the model concentrated on the Lower Mokelumne River system starting at the Mokelumne Hill gage upstream of Pardee Reservoir and culminating at the confluence with the Cosumnes River. The model was designed at the time to examine potential yield from the MORE Water Project, an off-stream storage reservoir that would capture non-appropriated high flows from the Mokelumne River and regulate this supply to an integrated system of conjunctive use projects to provide additional water supply and reliability for the region.

In 2012, MOCASIM was expanded to include representation of the Upper Mokelumne River Basin upstream of the Mokelumne Hill gage. The model was also enhanced to allow evaluating the water supply and hydroelectric benefits from future developments in the basin, including: Enlarged Lower Bear Reservoir, Raised Pardee Dam and MORE Water Project.

For the water supply benefits, the expanded MOCASIM could be used to evaluate the overall system non-appropriated water that could be managed in the additional storage created by the Enlarged Lower Bear Reservoir, Raised Pardee Dam and/or the off-stream storage reservoir at Duck Creek (MORE Water Project). These storage facilities could be operated in any sequence of development. Therefore, the expanded MOCASIM allows for the examination of the incremental benefits obtained from each project. Water stored in these new facilities could be

diverted at various points throughout the system for beneficial use, including groundwater recharge.

For the hydropower benefits, the expanded MOCASIM could be used to evaluate the additional generation of Project 137, resulting from the Enlarged Lower Bear Reservoirs, as well as the additional changes in generation from the Pardee and Camanche power plants.

Finally, MOCASIM is also equipped with the ability to assess the magnitude and duration of water availability for Groundwater Banking via existing or newly proposed diversion facilities in the system, by devising new agreements and water management policies amongst stakeholders.

### **3 Geographical Areas**

MOCASIM in its present configuration encompasses two interrelated geographical areas: The Upper Mokelumne system and the Lower Mokelumne system. The model can simulate the operation of each geographical area independently or in sequence (from top to bottom).

The time-step for simulating the Upper Mokelumne is daily while the time-step for simulation the Lower Mokelumne is monthly. The primary reason is that the Upper Mokelumne is “peakier” hydrology wise, than the Lower Mokelumne. The combined reservoirs’ storage in the Lower Mokelumne is an order of magnitude greater than the Upper Mokelumne, thus providing higher degree of attenuation of flood events (which coincides with the actual practice of regulating flow below Camanche for safety and environmental considerations). Furthermore, most the water rights and agreements associated with existing water users on the Lower Mokelumne were defined on a monthly basis. Internally in the model, the difference in time-step resolution is handled by converting the daily outflow from the Upper Mokelumne to monthly inflow to the Lower Mokelumne. The transition point is the Mokelumne Hill gage at Hwy 49 Bridge gage (USGS #11319500), immediately upstream of Pardee Reservoir.

The following describe the characteristics and operating rules associated with each geographical area as simulated in MOCASIM.

#### **3.1 Upper Mokelumne System**

The flow regime in the Upper Mokelumne system is primarily dominated by the operation of PG&E Project 137 on the North Fork Mokelumne. Project 137 consists of two reservoirs: Salt Springs and Lower Bear reservoirs and five hydroelectric power plants: and Salt Springs #1 & #2, Tiger Creek, West Point and Electra powerhouses. PG&E operates these facilities with consideration to power generation objectives, instream flow requirements mandated by the Federal Energy Regulatory Commission, and in accordance with the Lodi Decree<sup>i</sup>.

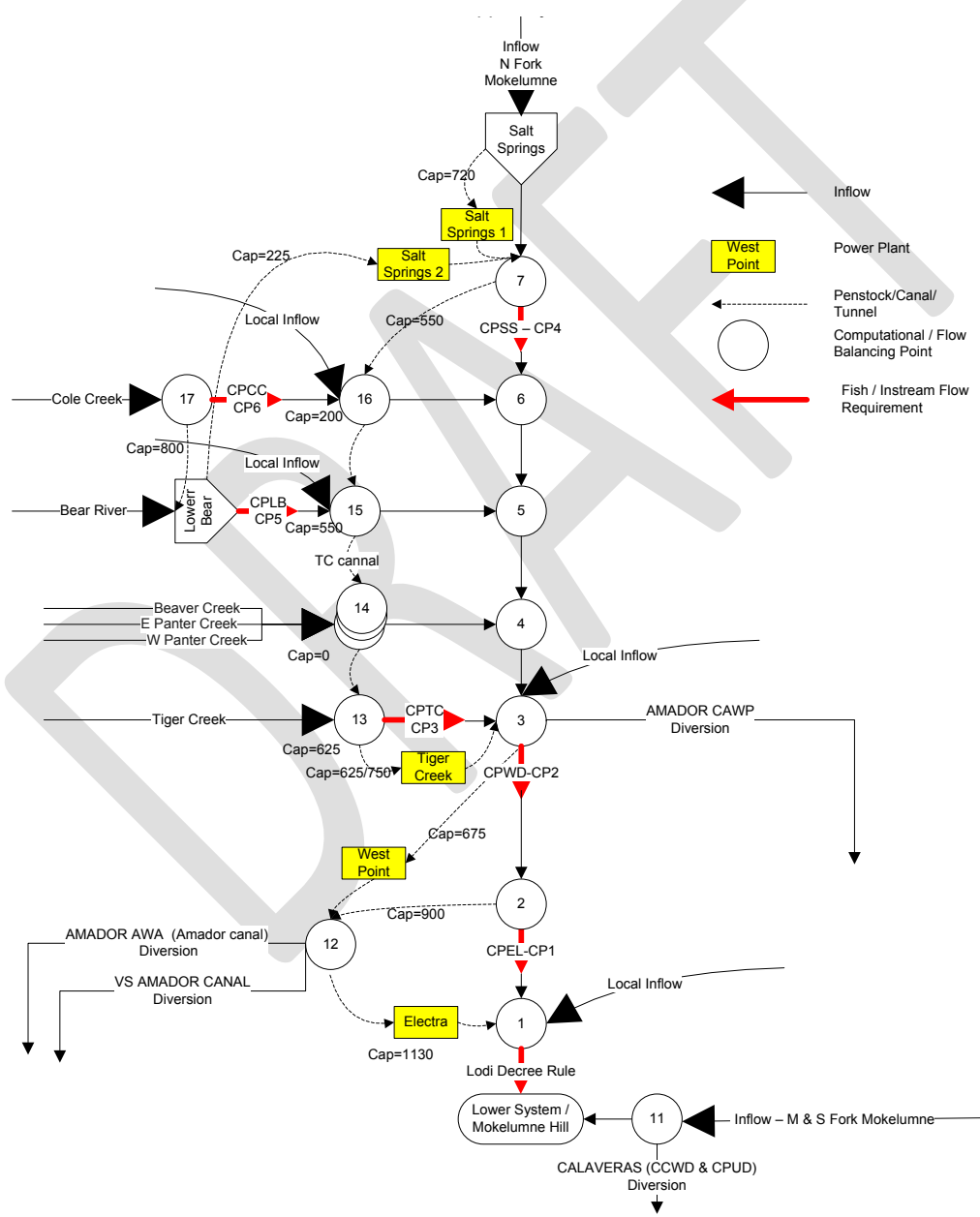
---

<sup>i</sup> The Lodi Decree is a series of court decisions from the 1940’s and 50’s that mandate average monthly outflow from Salt Springs and Lower Bear reservoirs as function of reservoirs’ storage.

MOCASIM is coded to include the physical characteristics of the upper basin including PG&E reservoirs, waterways and power plants as well as all applicable operational rules for these facilities. Figure 1 shows an overview of the Upper Mokelumne system as coded into MOCASIM.

In addition to the existing system, a new feature was added recently to the model where by it is possible now to analyze the potential additional yield from the proposed Enlarged Lower Bear Project. This feature is explained in more detailed in Section 5 of the TM.

**Figure 1- Upper Mokelumne System**





As shown in Figure 1, the Middle and South forks of the Mokelumne were combined in the model into a single inflow node (inflow to Node 11), as the flow in these forks is hardly regulated. Similarly, the watershed upstream of Salt Springs Reservoir is also represented as a single inflow component to the Salt Springs Reservoir because of the limited storage regulation in that area.

Other boundary conditions are: inflow to Lower Bear Reservoir, the flow in Cole Creek, Tiger Creek, and the combined flow from Beaver, East Panther and West Panther creeks. Local inflow is introduced in the model at discrete points as shown this schematic.

Primary facilities of Project 137 and operational rules that have been incorporated in the model are described herein (refer also to Figure 1 for waterways capacities):

**Figure 2 - Upper Mokelumne Reservoirs and Power Plants**

Reservoirs	Minimum (AF)	Maximum (AF)	Modeling Assumption
Salt Springs Reservoir	5,000	141,860	Reservoir operate based on target rule curve subject to downstream release requirements
Lower Bear Reservoir	2,150	52,020	Reservoir operate based on target rule curve subject to downstream release requirements
Upper Blue Lake Lower Blue Lake Twin lakes Reservoir Meadow Lake			Are not explicitly modeled. Represented as a single input node to Salt Springs Reservoir.
Upper Bear River Reservoir			Is not explicitly modeled. Represented as a single input node to Lower Bear Reservoir.
Cole Creek Diversion			Storage is not explicitly modeled. Represented as a diversion node.
Tiger Creek Regulator, Forebay and Afterbay			Are not explicitly modeled. Represented as diversion nodes.
Lake Tabeaud			Storage is not explicitly modeled. Represented as a diversion node.
Power Plants	Maximum (MW)	Maximum (CFS)	Modeling Assumption
Salt Springs #1	11.0	700	Usually not peaking (although model provides for this option)
Salt Springs #2	33.0	225	Usually not peaking (although model provides for this option)
Tiger Creek	58.0	750	Usually Peaking (defined by specified plant factors)
West Point	14.5	675	Usually Peaking (defined by specified plant factors)
Electra	92.0	1130	Usually Peaking (defined by

			specified plant factors)
--	--	--	--------------------------

**3.1.1 Lodi Decree**

The Lodi Decree establishes minimum flow and releases relative to reservoir storage levels in the North Fork Mokelumne Reservoirs. The flow is measured immediately upstream of the confluence with the Middle Fork Mokelumne River (Node 1 in Figure 1). The Lodi Decree is quite complex from the interpretation and implementation point of view. However, in the expanded model, the Lodi Decree was simplified by defining a required flow schedule in the North Fork (NF) as function of the combined storage in Salt Springs and Lower Bear reservoirs (SS+LB), as shown in Figure 3 below.

**Figure 3 - Lodi Decree**

(NF Flow schedule in CFS)			
Storage (SS+LB) when ?	Dry Year		Normal Year
	<130,000	>130,000	
month	always	the following flow or NF whichever is less	June 1st minimum flow
	and greater than:		
Jun	112,000	300	500
Jul	94,000	300	500
Aug	76,000	300	500
Sep	58,000	300	500
Oct	40,000	200	500
Nov	30,000	200	500
Dec	20,000	200	500
Jan	10,000	200	300
Feb	0	200	200
Mar	0	200	200
Apr	0	200	200
May	0	300	300

In the simplified Lodi Decree there are two year types depending on the combined storage in Salt Springs and Lower Bear reservoirs on June 1. If the storage is greater than 130 TAF, then the minimum required flow from the North Fork Mokelumne for the next 12 months is as prescribed in the table for Normal Year. If the storage on June 1 is less than 130 TAF, then the minimum required flow from the North Fork Mokelumne is in accordance with the prescribed schedule for Dry Year, but could also be reduced to as low as natural flow in a manner to gradually empty the reservoirs down to the target storage levels shown above (in the “and greater than” col.).

### **3.1.2 Instream flow requirements**

Instream flow requirements (see Figure 4) are mandated by FERC and are defined at six control points as depicted in Figure 1 (CP 1 to CP 6). FERC also requires maintaining pulse flow at these points as shown in Figure 5.

DRAFT

Figure 4 - FERC Instream Flow Requirements in CFS

<b>CP1 - NF below Electra Diversion</b>												
	Jan	Feb	Mar	Apr	May	Jun	Jul	Aug	Sep	Oct	Nov	Dec
<b>Critical Dry</b>	20	25	30	40	60	40	20	15	15	15	20	20
<b>Dry</b>	25	30	50	80	95	50	20	20	20	20	20	20
<b>Below Normal</b>	40	40	80	135	250	180	35	20	20	20	25	30
<b>Above Normal</b>	60	60	110	190	490	270	40	20	20	20	20	40
<b>Wet</b>	90	120	150	400	980	850	145	30	20	20	50	50
<b>CP2 - NF below Tiger Cr. Afterbay (bypass to West Point PP)</b>												
<b>Critical Dry</b>	20	25	30	40	60	40	20	15	15	15	20	20
<b>Dry</b>	25	30	50	80	95	50	20	20	20	20	20	20
<b>Below Normal</b>	40	40	80	135	250	180	35	20	20	20	25	30
<b>Above Normal</b>	60	60	110	190	490	270	40	20	20	20	20	40
<b>Wet</b>	90	120	150	400	980	850	145	30	20	20	50	50
<b>CP3 - Tiger Creek below Tiger Creek Regulator</b>												
<b>Critical Dry</b>	7	7	10	10	7	5	5	3	3	3	5	5
<b>Dry</b>	7	7	10	10	7	5	5	3	3	3	5	5
<b>Below Normal</b>	7	7	10	10	7	5	5	3	3	3	5	5
<b>Above Normal</b>	7	7	10	10	7	5	5	3	3	3	5	5
<b>Wet</b>	7	7	10	10	7	5	5	3	3	3	5	5
<b>CP4 - NF below Salt Springs Reservoir</b>												
<b>Critical Dry</b>	20	25	30	40	60	40	20	15	15	15	20	20
<b>Dry</b>	25	30	40	60	70	40	20	20	20	20	20	20
<b>Below Normal</b>	40	40	70	110	210	160	30	20	20	20	20	25
<b>Above Normal</b>	50	50	90	170	430	230	30	20	20	20	20	30
<b>Wet</b>	75	110	135	375	930	720	145	20	20	20	43	43
<b>CP5 - Bear River below Lower Bear</b>												
<b>Critical Dry</b>	4	6	6	10	8	6	40	4	4	4	4	4
<b>Dry</b>	6	8	10	25	20	8	6	4	4	4	6	6
<b>Below Normal</b>	10	10	15	25	40	20	10	6	4	4	6	8
<b>Above Normal</b>	14	14	20	30	70	40	15	6	6	6	8	10
<b>Wet</b>	20	20	25	50	110	70	30	15	6	6	15	15
<b>CP6 - Cole Creek below div. to Lower Bear</b>												
<b>Critical Dry</b>	2	2	4	8	6	4	2	2	2	2	2	2
<b>Dry</b>	4	6	8	15	14	8	2	2	2	2	4	4
<b>Below Normal</b>	8	8	10	25	50	15	6	4	4	4	4	6
<b>Above Normal</b>	10	10	15	30	70	30	15	6	6	6	6	8
<b>Wet</b>	15	15	20	45	100	60	25	10	6	6	12	12

**Figure 5 - FERC Pulse Flow Requirements in CFS**

CP/month	Critical Dry	Dry	Below Normal	Above Normal	Wet	Duration and timing
<b>CP1 - NF below Electra Diversion</b>						
May	0	500	1000	1800	0	5 continuous days
<b>CP2 - NF below Tiger Cr. Afterbay (bypass to West Point PP)</b>						
May	0	500	1000	1800	0	5 continuous days
<b>CP3 - Tiger Creek below Tiger Creek Regulator</b>						
Feb	35	35	35	35	35	one day
Mar	35	35	35	35	35	one day
<b>CP4 - NF below Salt Springs Reservoir</b>						
May	0	500	1000	1800	0	5 continuous days
<b>CP5 - Bear River below Lower Bear</b>						
May	0	300	570	700	0	5 continuous days
<b>CP6 - Cole Creek below div. to Lower Bear</b>						
May	0	0	Natural Flow	Natural Flow	Natural Flow	5 continuous days

Note: for modeling purposes, it was assumed that pulse flow is triggered at the beginning of the month.

### 3.1.3 Upper Mokelumne System Operation

The operation of the upper Mokelumne River System can be summarized as follows:

1. Minimum demand of the System is computed starting with most downstream point (Node 1) taking into account the Lodi Decree, instream flow requirements, diversion, local runoff and power plants plant factors (if specified).
2. Maximum demand is calculated the same way except assuming maximum plant factor for all power plants (=1). This demand represents the maximum release from the upper reservoirs (Salt Springs and Lower Bear) without hydropower spill.
3. Maximum and minimum demands are divided between Salt Springs (SS) and Lower Bear (LB) reservoirs based on storage ratios  $LB / (SS+LB)$ ,  $SS / (SS+LB)$ .
4. If the computed storage falls below the reservoir rule curve with minimum demand, the model accepts the minimum demand as the release.
5. If the computed storage is above the reservoir rule curve with maximum demand, the model accepts the maximum demand as the release.
6. Otherwise, the model releases to hit the rule curve.

### 3.1.4 Power plants operation

The operation of the power plants in the upper Mokelumne River System when plant factors are specified (usually for Tiger Creek, West Point and Electra power plants), can be summarized as follows:

1. The model always tries to run at maximum flow (assuming maximum power).
2. If the available flow is less than the maximum for the specified plant factor, the plant factor is modified to accommodate maximum flow.
3. Two flow rates are reported – average during period (24 hours) and flow ‘producing’, meaning flow corresponding to the resulting plant factor.

### 3.1.5 Test run

A test run was made to evaluate how well the model simulates the operation the Upper Mokelumne system. Results of the model run for energy production by power plant vs. actual generation provided by PG&E are presented in Figure 6 below. Note that the period selected is 2001 to 2010, as the year 2001 is the first year when the new FERC instream flow requirements per the relicensing articles for Project 137 been implemented.

The results demonstrate that MOCASIM estimates match pretty well (within 98% for the overall system) the actual generation of Project 137 given the fact that other factors such as outages, day-to-day operational decisions, shutdown due to maintenance, etc., are not included in the model.

**Figure 6 - Test Run for Energy Production**

<b>MOCASIM II Estimated Energy Generation vs. Actual</b>						
(MWH)						
	<b>SALT SPRINGS #1</b>	<b>SALT SPRINGS #2</b>	<b>TIGER CREEK</b>	<b>WEST POINT</b>	<b>ELECTRA</b>	<b>TOTAL</b>
<b>Actual</b>						
2001	13,212	106,436	231,992	65,122	296,902	713,664
2002	27,022	199,406	322,871	90,307	399,545	1,039,151
2003	33,710	179,992	310,237	93,862	444,021	1,061,822
2004	26,896	128,824	301,124	88,424	373,436	918,704
2005	36,565	203,843	339,430	100,854	555,477	1,236,169
2006	51,911	214,619	334,700	100,216	553,951	1,255,397
2007	15,251	103,395	211,904	59,952	283,109	673,610
2008	20,037	117,381	231,223	63,576	292,082	724,299
2009	32,550	152,502	288,839	87,052	423,773	984,716
2010	21,403	139,747	255,828	84,672	456,641	958,291
<b>TOTAL</b>	<b>278,556</b>	<b>1,546,146</b>	<b>2,828,149</b>	<b>834,036</b>	<b>4,078,935</b>	<b>9,565,823</b>
<b>MOCASIM II</b>						
2001	14,482	115,404	226,331	71,610	256,710	684,537
2002	26,743	184,671	300,147	97,144	370,219	978,924
2003	30,244	182,497	300,714	100,332	399,103	1,012,890
2004	23,183	167,684	304,603	97,170	371,880	964,520
2005	34,476	210,958	343,286	117,338	536,611	1,242,669
2006	50,773	245,216	354,742	118,540	576,630	1,345,901
2007	15,248	149,746	235,163	75,127	267,520	742,804
2008	20,673	149,245	260,411	80,270	286,733	797,332
2009	35,013	174,744	291,158	92,212	368,383	961,510
2010	33,453	160,545	294,835	97,601	419,397	1,005,831
<b>TOTAL</b>	<b>284,288</b>	<b>1,740,710</b>	<b>2,911,390</b>	<b>947,344</b>	<b>3,853,186</b>	<b>9,736,918</b>
<b>Actual/MOCASIM II</b>						
2001	91%	92%	103%	91%	116%	104%
2002	101%	108%	108%	93%	108%	106%
2003	111%	99%	103%	94%	111%	105%
2004	116%	77%	99%	91%	100%	95%
2005	106%	97%	99%	86%	104%	99%
2006	102%	88%	94%	85%	96%	93%
2007	100%	69%	90%	80%	106%	91%
2008	97%	79%	89%	79%	102%	91%
2009	93%	87%	99%	94%	115%	102%
2010	64%	87%	87%	87%	109%	95%
<b>TOTAL</b>	<b>98%</b>	<b>89%</b>	<b>97%</b>	<b>88%</b>	<b>106%</b>	<b>98%</b>

### 3.2 Lower Mokelumne System

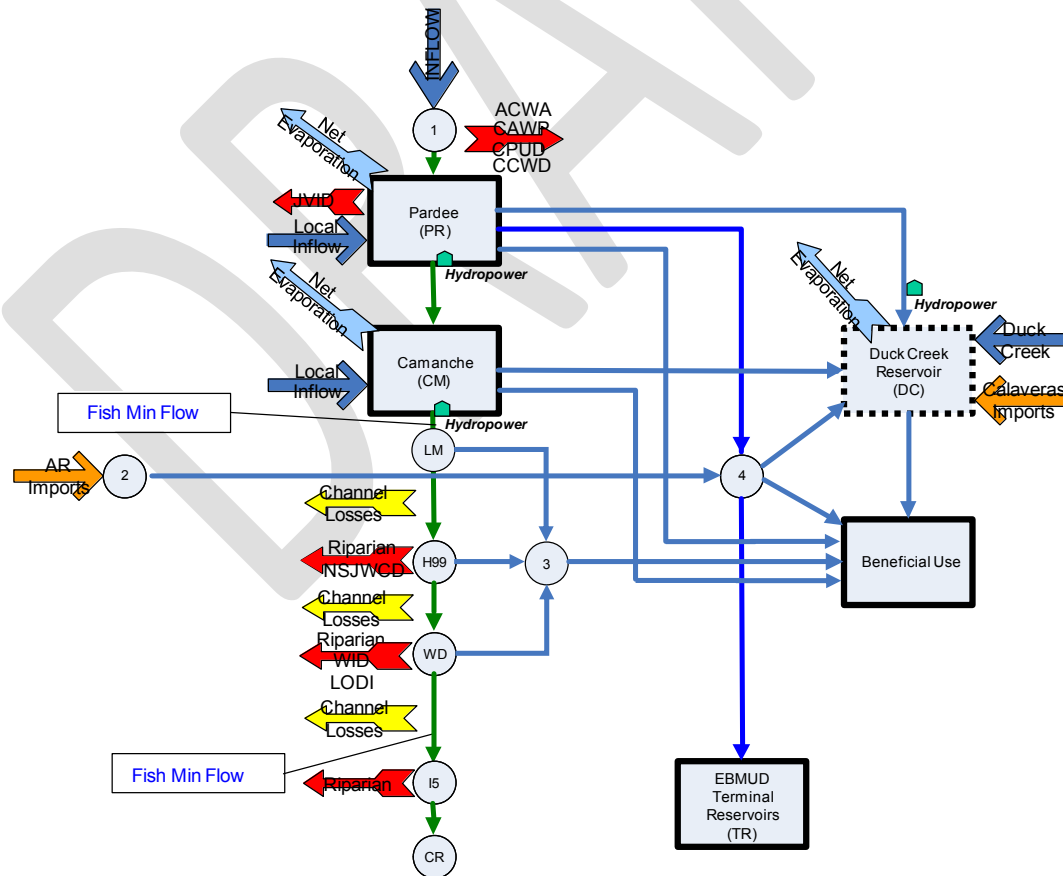
The Lower Mokelumne system as depicted in MOCASIM consists of two primary components:

1. The Existing System – Encompasses Pardee and Camanche Reservoirs, the Mokelumne Aqueduct which conveys water from Pardee Reservoir to the EBMUD Terminal Reservoir Area (TRA), and the lower Mokelumne River downstream of Camanche Reservoir to I5. The reach below I5 is considered as the contribution to the North Delta (not including the contribution from the Cosumnes River).
2. Proposed New Projects – Consist of proposed facilities in the Mokelumne River System that would divert water to the place of use for beneficial use. Water could also be diverted to storage facilities, such as the proposed Duck Creek Reservoir (MORE Water Project).

Secondary components of the model include water imported from the American River through the Freeport Regional Water Project to the Mokelumne Aqueduct and to Duck Creek Reservoir, and water imported from the Calaveras River Basin (Stockton East Water District water supply system) to Duck Creek Reservoir.

A logical overview of Lower Mokelumne as coded into MOCASIM is presented in Figure 7 below:

**Figure 7 - MOCASIM Logical Overview.**



The inflow in Node 1 in the above Logical Overview represents the entire flow from the Upper Mokelumne watershed, as measured at the Mokelumne Hill gage after adjustment for historical diversion by Amador and Calaveras counties (historical diversions were added to the gauged data to allow simulation of future diversion by these counties under various levels of development). This option is superseded if the mode is run a mode where the Upper Mokelumne system is operated first and the outflow from the upper system becomes the inflow to the lower system.

The operation of the Lower Mokelumne is driven by a series of water rights and agreements, instream flow requirements, channel loss, and flood control rules.

The following is a brief description of those.

**3.2.1 Upstream Diversion**

Upstream water users include Amador County and Calaveras County. The model has the provision to handle specific entities within these counties as shown in:

Amador County:

- Amador Water Agency (ACWA) via Amador Canal Diversion
- Amador Water Agency via Central Amador Water Project (CAWP)
- Jackson Valley Irrigation District (JVID)

Calaveras County:

- Calaveras Public Utility District (CPUD)
- Calaveras County Water District (CCWD)

The water allocation to upstream users depends on the basin’s level of development. MOCASIM uses the year 2020 as the default year for level of development. The default allocations to the upstream users can be overridden by specifying explicit numbers in the input file.

**Figure 8 - Annual Upstream Diversions**

User	Level of Development	
	2020	Max
Amador County	20.0	20
(Total)	18.0	
ACWA	2.0	
CAWP		
JVID*		
Calaveras County	11.7	27
(Total)	4.9	
CPUD	6.8	
CCWD		
Total	31.7	47

\* JVID demand is included in ACWA demand in 2020 Level of Development

The model assumes that the annual allocation to the upstream users is distributed on a monthly basis in accordance with the percentages depicted in Figure 9.



**Figure 9 - Percent Distribution of Annual Diversion to Upstream Users**

	Jan	Feb	Mar	Apr	May	Jun	Jul	Aug	Sep	Oct	Nov	Dec
Amador												
ACWA	5.8%	5.6%	6.2%	6.8%	8.9%	10.4%	11.7%	12.0%	10.4%	8.6%	7.1%	6.5%
CAWP	5.8%	5.6%	6.2%	6.8%	8.9%	10.4%	11.7%	12.0%	10.4%	8.6%	7.1%	6.5%
JVID	0.0%	0.0%	12.5%	12.5%	12.5%	12.5%	12.5%	12.5%	12.5%	12.5%	0.0%	0.0%
Calaveras												
CPUD	6.9%	5.7%	5.8%	8.2%	10.0%	11.7%	11.1%	10.6%	9.2%	7.4%	6.6%	6.9%
CCWD	6.9%	5.7%	5.8%	8.2%	10.0%	11.7%	11.1%	10.6%	9.2%	7.4%	6.6%	6.9%

The flow after being regulated by PG&E's system and reduced by the upstream diversions becomes the inflow to Pardee Reservoir. The flow is measured at the USGS gaging station Mokelumne River near Mokelumne Hill (near Hwy. 49 Bridge).

In simulating future conditions on the river, MOCASIM uses historical flow at the gage adjusted for the difference between the historical upstream diversion and newly projected ones.

### 3.2.2 EBMUD Water Supply System

The EBMUD water supply system on the Mokelumne River consists of Pardee Reservoir and power plant, Camanche Reservoir and power plant, and the Mokelumne Aqueducts, which deliver water to the EBMUD service area. The operation of the EBMUD system is modeled with the MOCASIM model, as follows:

#### 1. Pardee Reservoir and Power Plant:

Pardee Reservoir has a gross storage capacity of about 198 TAF. It fills up and draws down to target storage levels using forecasting procedures that minimize reservoir spills. This mode of operation takes into account delivery of water to EBMUD customers via the Mokelumne Aqueducts and releases to Camanche in order to supply Lower Mokelumne flow requirements.

Pardee power plant is situated at the base of Pardee Dam and contains three Francis turbines with a total generating capacity of 28,650 kilowatts. The total rated flow for the plant is 1,100 cfs. MOCASIM assumes that Pardee power plant operates at a uniform flow rate governed by water supply and flood control rules (no peaking).

Because of limited information from public documents about the characteristics of Pardee power plant, MOCASIM is using generic performance curves for Francis turbines. Refinement of these curves is recommended if PG&E or EBMUD will release this information in the future.

#### 2. Camanche Reservoir and Power Plant:

Camanche Reservoir has a gross storage capacity of about 417 TAF. It provides releases to meet flow requirements for the Lower Mokelumne River, including: water demands by downstream diverters, releases to offset channel depletion (loss), fish release, and provides releases to maintain flood control space in the system.

Camanche power plant is situated at the base of Camanche Dam and contains three Kaplan turbines with a total generating capacity of 10,680 kilowatts. The total rated flow for the plant is 1,200 cfs. MOCASIM assumes that Camanche power plant operates at a uniform flow rate (no peaking).

Because of limited information from public documents about the characteristics of Camanche power plant, MOCASIM is using generic performance curves for Kaplan turbines. Refinement of these curves is recommended if PG&E or EBMUD will release this information in the future.

### 3. Aqueduct Draft and Early Deficiency Rules

EBMUD demand is expressed in the model as average annual daily demand in Million Gallons per Day (MGD) and percent distribution by month. EBMUD demand is delivered from Pardee Reservoir via the Mokelumne Aqueduct to terminal reservoirs in the Bay Area.

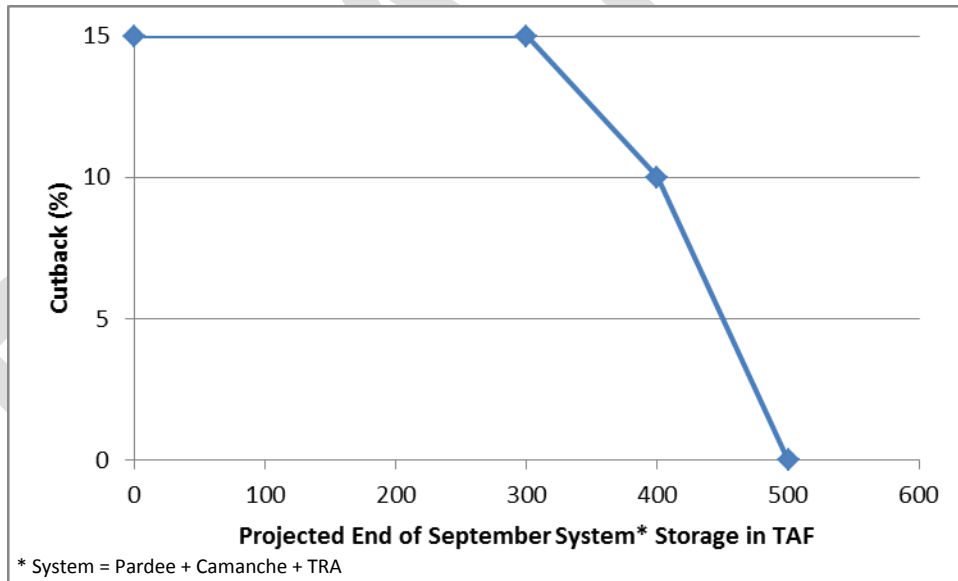
The maximum capacity of the Mokelumne Aqueduct is assumed to equal 325 MGD (approximately 500 cfs) which is EBMUD’s full allocation under its water rights. The terminal reservoirs in the Bay Area are represented in the model by a single reservoir called Terminal Reservoir Area (TRA) with a combined capacity of 160 TAF.

The TRA has target storage levels which the model tries to maintain during the simulation. Water is withdrawn from the TRA only when there is shortage in supply from Mokelumne Aqueduct (Pardee Reservoir).

In dry years when shortages in supply occur, EBMUD imposes rationing on its customers called in the model Early Deficiency Rules. These rules impose cutback of deliveries to EBMUD whenever total system storage at the end of September is projected to fall below 500 TAF. The total system storage is defined as the combined storage in Pardee, Camanche and TRA.

The Early Deficiency Rules result in a sliding scale of reduction to EBMUD demand, depending on projected end of September total system storage levels, as shown in Figure 10.

**Figure 10 - EBMUD Early Deficiency Rules**



MOCASIM mimics hydrologic forecasting by employing iterative process of decision making as explained above. Accordingly, the model operates the system first without cutback until end of September. If system storage falls below 500 TAF, it defines the percent cutback based on the Early Deficiency Rules, resets the simulation Clock to January and re-operates the system again imposing cutback on EBMUD demand. This concept is consistent with the way EBMUD models customer cutback as found in public documents.

Another provision in MOCASIM is to assume that in the first year of a drought the model reduces the computed cutback by 50%. The logic is that, in the first year of the drought, it could take up to

six months before customers respond to the imposed conservation measures. This concept is also compatible with EBMUD modeling assumptions.

### 3.2.3 Flood Control Operation

Flood control operation is one of the most important factors in estimating the available water for future developments in the basin as described in Section 5.1 below.

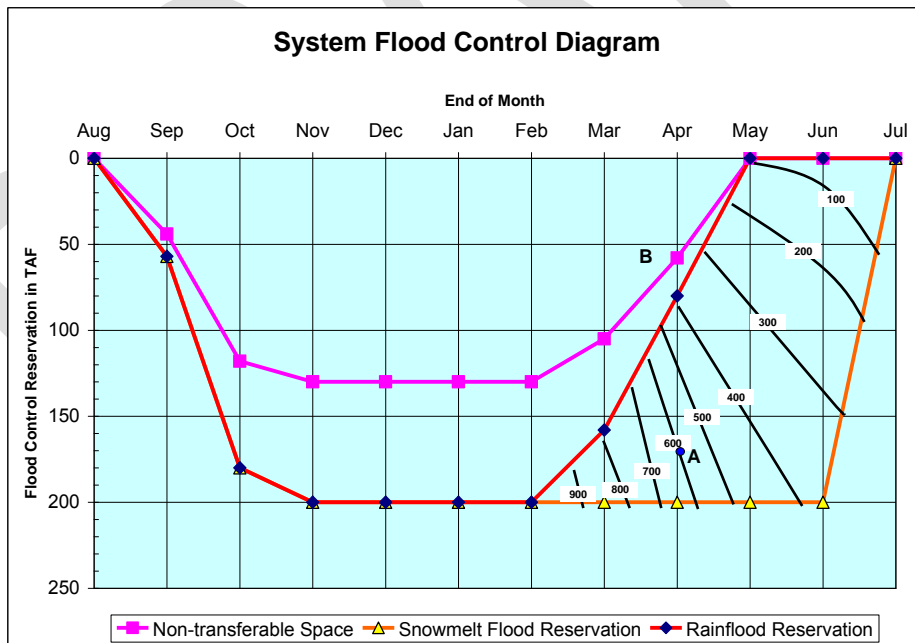
The flood control operation must be done in accordance with the US Army Corps of Engineers (COE) Flood Control Manual for the Mokelumne River Basin and can be summarized as follows:

- System’s flood control requirements is 200 TAF from November 15 to March 15
- Up to 70 TAF is transferable to PG&E’s Salt Springs and Lower Bear reservoirs based on COE guidelines (only a portion of the free space in PG&E’s reservoirs can be used to offset flood space requirements in Pardee and Camanche reservoirs).
- Flood control space can be divided in any portion between Pardee and Camanche reservoirs.
- After March 15, flood storage space requirements are based on rainfall and snow pack estimates (see example in Figure 11).

The system flood control diagram is presented in Figure 11.

MOCASIM simulates the above-mentioned flood control operation rules, with some approximation subject to the model’s time-step resolution.

**Figure 11 - Flood Control Diagram**



Example: If on the end of April the forecasted runoff from May 1 to July 31 is 600 TAF (point A on the 600 TAF curve), then the total flood space requirement is 170 TAF of which 60 TAF (point B) is non-transferable and 110 TAF is transferable (170-60=110). Of this amount, 20 TAF is for rainflood reservation and 90 TAF is for snowmelt reservation. The transferable space is further reduced depending on the free space in PG&E’s Salt Springs and Lower Bear reservoirs.

### 3.2.4 Lower Mokelumne Watershed

The Lower Mokelumne Watershed is defined as the portion of the Mokelumne basin downstream of Camanche Reservoir. The flow regime in this area is governed by the need to supply water for downstream water users (diversions), channel losses and fish release requirements, as follows:

#### 1. Diversions:

Diversions to downstream users depend primarily on the hydrologic conditions. Figure 12 summarizes the diversion amounts on an annual basis:

**Figure 12 - Annual Downstream Diversions**

User	Amount (TAF)	Comments
Riparian & Senior Appropriators	20	When Oct to Jun TNF is greater than 250 TAF (see Note 1)
	16.1	When Oct to Jun TNF $\leq$ 250 TAF, diversions in July, August and September are reduced to 50%
North San Joaquin Water Conservation District (NSJWCD)	20	In normal years
	0	When Camanche storage is in deficit (see Note 2)
Woodbridge Irrigation District (WID)	60	When Pardee actual inflow is greater than 375 TAF
	39	When Pardee Actual Inflow is less than 375 TAF
City of Lodi	3.6	All years (see Note 3)

Notes:

- 1) TNF is the True Natural Flow as measured at the Mokelumne Hill gage.
- 2) NSJWCD supply can be modeled in two ways:
  - Providing full supply up to 20 TAF every year
  - Providing water equal to the projected November spill (but not more than its full allocation amount of 20 TAF)
- 3) City of Lodi supply is based on the Lodi Decree which allows the city to divert water to offset declining groundwater levels.

The model assumes that the annual allocation to the downstream users is distributed on a monthly basis in accordance with the following percentages:

**Figure 13 - Percent Distribution of Annual Diversion to Downstream Users**

	Jan	Feb	Mar	Apr	May	Jun	Jul	Aug	Sep	Oct	Nov	Dec
Riparian												
Dry Year	0.9%	0.8%	2.5%	8.1%	20.6%	29.3%	14.3%	9.3%	4.7%	4.4%	1.9%	3.4%
Wet Year	0.7%	0.6%	1.9%	6.3%	16.0%	22.8%	22.3%	14.6%	7.3%	3.4%	1.4%	2.6%
WID												
Dry Year	0.0%	0.0%	1.0%	8.4%	14.8%	19.2%	21.9%	18.9%	12.1%	3.6%	0.0%	0.0%
Wet Year	0.0%	0.0%	0.7%	5.3%	12.9%	18.4%	22.8%	21.1%	12.5%	6.3%	0.0%	0.0%
NSJWCD												
All Years	0.0%	0.0%	0.0%	0.0%	17.0%	23.0%	27.0%	17.0%	10.0%	6.0%	0.0%	0.0%
Lodi												
All Years	0.0%	0.0%	3.4%	14.9%	18.4%	17.7%	17.4%	16.6%	8.9%	2.5%	0.0%	0.0%

**2. Fish Release Requirements:**

MOCASIM includes the fish flow requirements agreed upon in the 1997 Joint Settlement Agreement. The Agreement prescribes minimum release requirements below Camanche Reservoir in different year types, subject to meeting minimum flow conditions below Woodbridge Diversion Dam. In other words, if the minimum release required from Camanche does not result in flow below Woodbridge as prescribed in the schedule, Camanche release has to increase accordingly.

The annual fish release requirements are summarized in Figure 14 below:

**Figure 14 - Fish Release Requirements in CFS**

Year Type	Requirements	Oct	Nov	Dec	Jan	Feb	Mar	Apr	May	Jun	Jul	Aug	Sep	Annual (TAF)
Normal	Minimum Camanche Release	325	325	325	325	325	325	325	325	325	100	100	100	194
Below Normal		250	250	250	250	250	250	250	250	250	100	100	100	154
Dry		220	220	220	220	220	220	220	220	220	100	100	100	130
Critical		115	130	130	130	130	130	130	130	100	100	100	100	80
Normal	Expected Flow below Woodbridge Diversion Dam	100	100	100	100	100	100	150	300	300	25	25	25	86
Below Normal		100	100	100	100	100	100	150	200	200	20	20	20	73
Dry		80	80	80	80	80	80	150	150	20	20	20	20	52
Critical		45	75	75	75	75	75	75	15	15	15	15	15	34

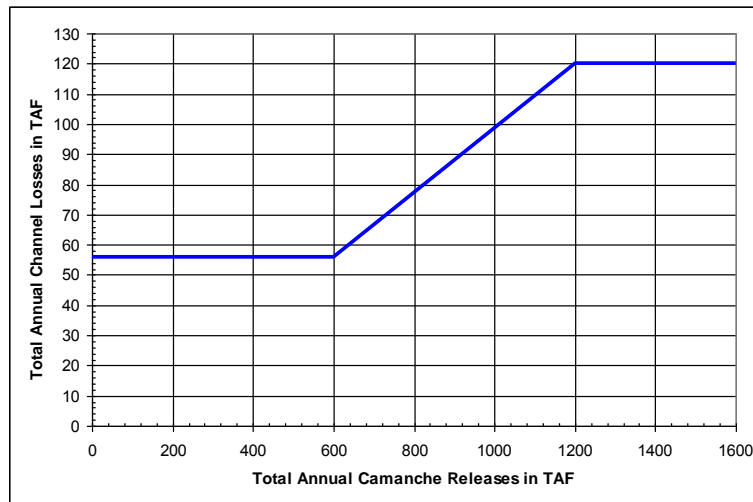
**3. Channel Losses:**

Channel losses to the groundwater basin occur in the Lower Mokelumne River. EBMUD, under water rights agreements with other water users on the river, is obligated to release sufficient water to ensure that entitlements are delivered to the users at the point of diversion.

Channel losses deplete the amount of water in the river, thus requiring EBMUD to increase the releases from Camanche Dam to compensate for the losses. MOCASIM incorporates the same methodology used by EBMUD for modeling channel losses (obtained from public records).

Channel losses in the model depend on the total release from Camanche as illustrated in Figure 15.

**Figure 15 - Channel Losses on the Lower Mokelumne as function of Camanche Release**



### 3.2.5 Freeport Project (American River Import)

Import of water from the American River via the Freeport Project is considered an integral part of current system operation. In general, water is pumped directly into the Mokelumne Aqueduct during dry years thus serving EBMUD customers and reducing the stress on the Mokelumne River water system. As in the early deficiency rules, American River Import is triggered by the projected end of September Total System Storage (also when below 500 TAF).

The Freeport pipeline is also an element of the proposed MORE Water Project. The original concept was to have the flexibility to “rent space” in the pipeline whenever EBMUD is not diverting. Here again, the Freeport mechanism as coded into MOCASIM could be used as a way to assess the viability of the American River import to the Mokelumne Basin, if such alternative would be considered under the MokeWISE Program.

## 4 Hydrology and Simulation Period

The primary source of flow hydrologic data used in MOCASIM is the recorded flow at the Mokelumne Hill Gage (USGS # 11319500), immediately upstream of Pardee Reservoir. The simulation period in the model is 1953-2010. A flow duration curve showing monthly flow measured at the gage is provided in Figure 16. The figure also shows the annual runoff in each year for this period.

The starting year 1953 was selected because it provides the first year for which complete records for storage conditions in the Upper Mokelumne River Basin are available. Storage conditions in PG&E’s reservoirs at the Upper Mokelumne River Basin (so-called Project 137), namely, Salt Springs and Lower Bear reservoirs are important factors for the simulation as MOCASIM considers the available space in these two reservoirs when computing the required flood control space in the Pardee-Camanche reservoirs system (per the COE flood control rules). Lower Bear Reservoir, the more recently constructed of the two, was completed in 1952 and storage conditions have been available since January 1953, thus defining the beginning year for the simulation period. The year 2010 is the last year for which complete hydrological data were compiled for the latest version of the model.

As explained earlier the model can simulate the operation of the Upper Mokelumne as a standalone system. To do so, an additional hydrologic data set was developed. Unlike the Lower Mokelumne which operates in the model on a monthly time step (a reasonable assumption given the ability to regulate flow in Pardee and Camanche reservoirs), the Upper Mokelumne required higher level of resolution given the limited storage in the Upper Mokelumne reservoirs to regulate flow. As such, a daily time step was selected for the upper watershed.

The data was synthesized from over two dozen hydrological monitoring stations provided by PG&E, USGS and CDEC as shown in Figure 17. This resulted in developing ten discrete inflow time series as illustrated in the logical view in Figure 1 and explained below:

1. **SALT SPRINGS** : Inflow to Salt Springs Reservoir
2. **LOWER BEAR** : Inflow to Lower Bear Reservoir
3. **COLE CREEK** : Inflow to Cole Creek above Diversion Dam (Node 17)
4. **COLE CREEK LOCAL** : Runoff between Cole Creek Diversion Dam and Tiger Creek Canal (Node 16)
5. **BEAR RIVER LOCAL** : Runoff between Lower Bear Dam and Tiger Creek Canal (Node 15)
6. **OTHER TIGER CREEK** : Runoff from Beaver, East and West Panther creeks (Node 14)
7. **TIGER CREEK** : Inflow to Tiger Creek Regulator (Node 13)
8. **TIGER CREEK AB – LOCAL** : Runoff between Salt Springs Reservoir and Tiger Creek Afterbay (Node 7 to Node 3)
9. **NF,SF,MF - LOCAL TO NODE 1** : Runoff between Tiger Creek Afterbay and the Mokelumne River upstream of Mokelumne Hill Gage (Node 3 to Node 1). This also includes local runoff between Calaveras County diversion on the South and Middle forks Mokelumne (Node 11) and Node 1.
10. **MS FORK MOKELUMNE – LOCAL** : Inflow from the Middle and South forks Mokelumne before Calaveras County diversion (Node 11)

**Figure 16 - MOCASIM Hydrology**

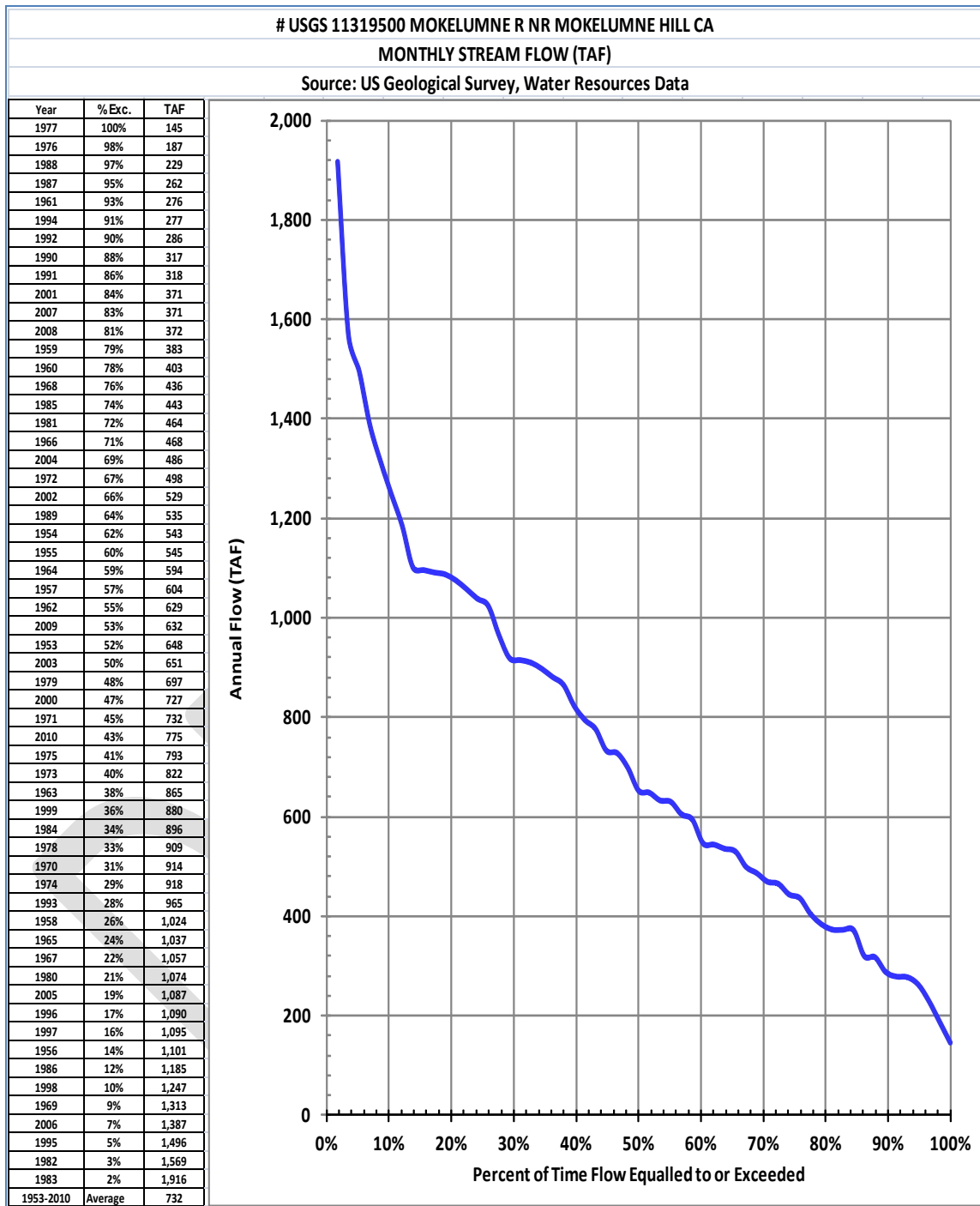




Figure 17 - Hydrological Monitoring Stations in the Mokelumne River Basin

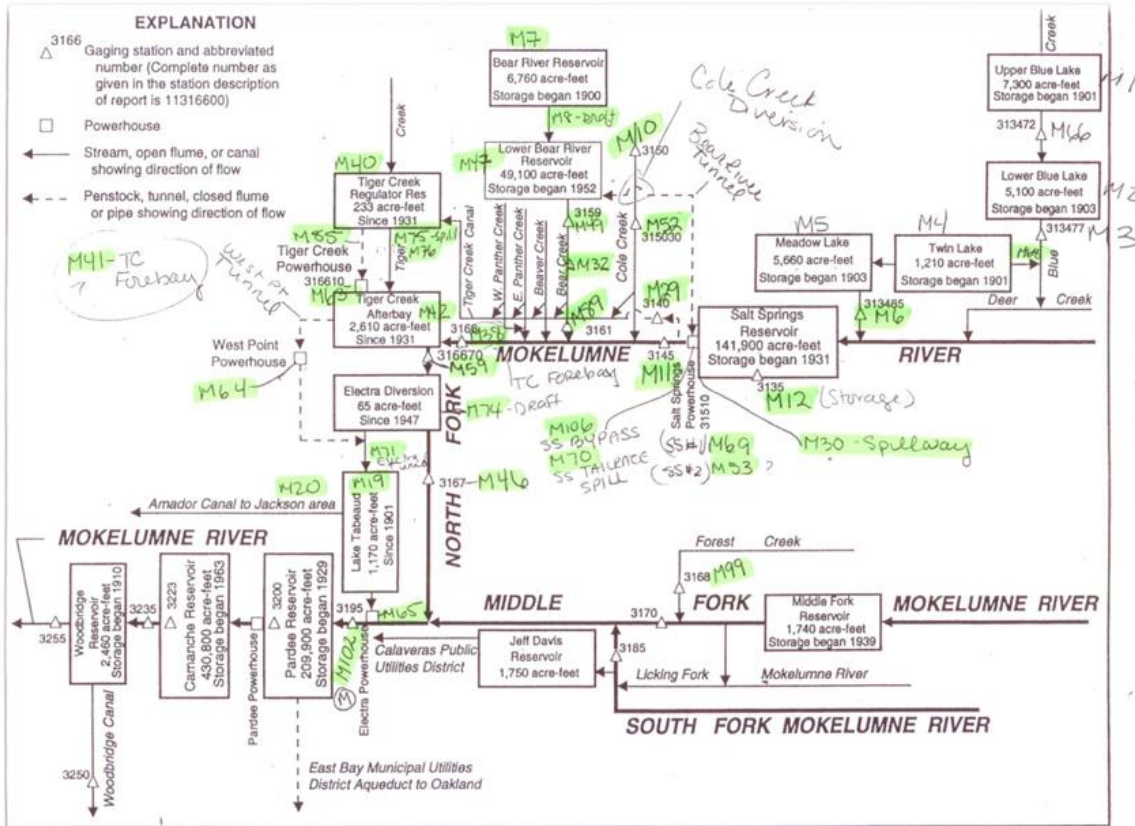


Figure 35: Diversions and storage in Mokelumne River basin.

M106 = SS #1 Bypass Flow

8330 - M902 - Moke @ Salt Springs

## 5 System Operation

MOCASIM was designed in mind to perform specifically water availability analysis and then to assess the potential yield from proposed new developments in the Mokelumne watershed.

In order to do so, the model is run, internally, in several passes (i.e., it performs full simulation for the entire simulation period several times):

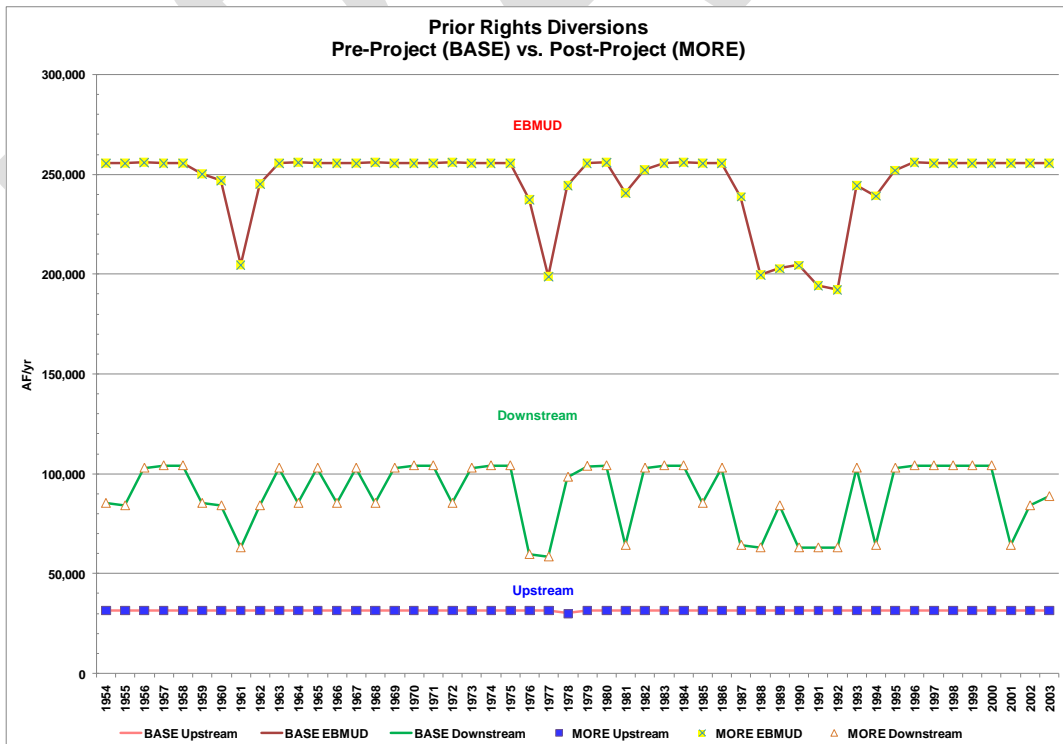
- 1) In the first pass, MOCASIM simulates the operation of the existing facilities in the Mokelumne River system in accordance with current water rights permits and agreements. The results of this pass are the deliveries to all existing users and the magnitude and duration of non-appropriated water. In general, non-appropriated water is defined in the model as the flow to the Bay-Delta (as measure at I5 Bridge, not including the contribution from the Cosumnes River), in excess of what is needed to satisfy all existing users in the entire Mokelumne River system (Upper and Lower), including fish flow (see more about this in Section 5.2).

- 2) In the second pass, MOCASIM allocates the non-appropriated water for beneficial use through new developments. New developments may include additional on-stream storage (e.g., enlarged Lower Bear or Pardee reservoirs), off-stream storage (e.g., Duck Creek Reservoir), direct diversion for water supply, or groundwater recharge.
- 3) A third pass is a private case for stacking new developments (i.e., developing several projects in sequence). Essentially, it computes the yield for direct diversion (e.g., surface water supply or groundwater recharge) and diversion to off-stream storage (e.g., Duck Creek) after the implementation of on-stream storage development (e.g., enlarged Lower Bear or Pardee reservoirs).

The underlying concept in the second and third passes is that water allocation computed from the previous pass is maintained in full (both amount and time of delivery). For example: two new developments are being considered - (1) enlarging Lower Bear reservoir and (2) groundwater recharge by diverting water through new facilities below Camanche. In this case, three passes will take place: first – the model will run a base case (existing conditions) and will define the non-appropriated water. Second – portion of the non-appropriated water will be stored in the enlarged Lower Bear (for use by any water user throughout the system) and the model will redefine the remaining non-appropriated. Third – portion the remaining the non-appropriated water will be diverted for groundwater recharge. Since each project is built upon conditions from the previous pass, none of the users from the previous passes will be impacted. In this example, EBMUD will be kept whole and the new developments will not affect deliveries from Pardee to the TRA, customer cutback, Freeport imports, etc.

The following is an illustration of how the model ensures that existing users are kept whole (Pre-Project) after the implementation of the MORE Water Project (Post-Project) in this case.

**Figure 18 - Example for Prior Rights Diversion under Pre and Post Project**



It should be noted that on-stream storage development such as enlarged Lower Bear Reservoir or enlarge Pardee Reservoir, presents a modeling challenge as far as water accounting is concerned, as the “new” water being stored in the enlarged reservoir (from the second pass) co-mingles with the “old” water (from the first pass). Yet, when operating the reservoir, two different rules (demands) are applied: one to the “old” water (based on existing agreements and water rights) and one to the “new” water (based on new agreements between the project’s partners). To deal with that, a new concept was developed called Virtual Storage, as discussed in Section 5.2 below.

However, before discussing the VS concept, it is important to understand how the non-appropriated water is defined in the model:

## 5.1 Non-Appropriated Water

In its most basic form, non-appropriated is defined as the flow to the Bay-Delta (as measure at I5 Bridge, not including the contribution from the Cosumnes River) in excess of what is needed to satisfy all existing users in the entire Mokelumne River system (Upper and Lower), including fish flow. However, since MOCASIM is designed to “capture” non-appropriated water at three discrete points in the system, i.e., Lower Bear Reservoir, Pardee Reservoir and downstream of Camanche Reservoir, not all the non-appropriated water as measured at I5 is physically available those points. For example, Lower Bear Reservoir cannot capture the flood flow from the Middle and South forks of the Mokelumne, while Pardee Reservoir (or Duck Creek Reservoir for that matter) can. Therefore, depending of the development being considered, the model “knows” how to compute the non-appropriated water, thus providing a realistic assessment of how much “new” water is really available.

It is also important to note that since non-appropriated water is defined as “water in excess of what is needed to satisfy all existing users in the entire Mokelumne River system”, MokeWISE partners should agree upon the level of development that constitutes existing conditions or the base case. MOCASIM provides the flexibility to examine various levels of development for the base case and perform a sensitivity analysis for the non-appropriated water, as such.

## 5.2 Virtual Storage Concept

The Virtual Storage (VS) represents the additional storage space in the reservoir obtained from the proposed development (either by raising Pardee Dam or enlarging Lower Bear Reservoir) and where “new” water can be stored. The “new” water is essentially the non-appropriated water that would have otherwise spilled, as quantified by the first pass described above. MOCASIM is tracking separately the quantity of “old” and “new” water at any given time and applying different demands and water rights priorities rules to those two categories of water.

Using the VS concept, it is possible to look at sequencing future developments in the basin, including MORE, and to quantify the yield obtained from each development. The general principles in operating in a VS mode are summarized below (LB=Lower Bear, P=Pardee, DC=Duck Creek, LM=Lower Mokelumne):

- Define additional storage at each reservoir (VS)  
(for example: 30K for LB, 170K for P, 150K for DC)
- Define available non-appropriated water (from 1st pass)
  - a. At Camanche (Camanche Spill)
  - b. At Pardee: min(spills at Pardee, spills at Camanche)
  - c. At Lower Bear: min(spills at LB, spills at Pardee)

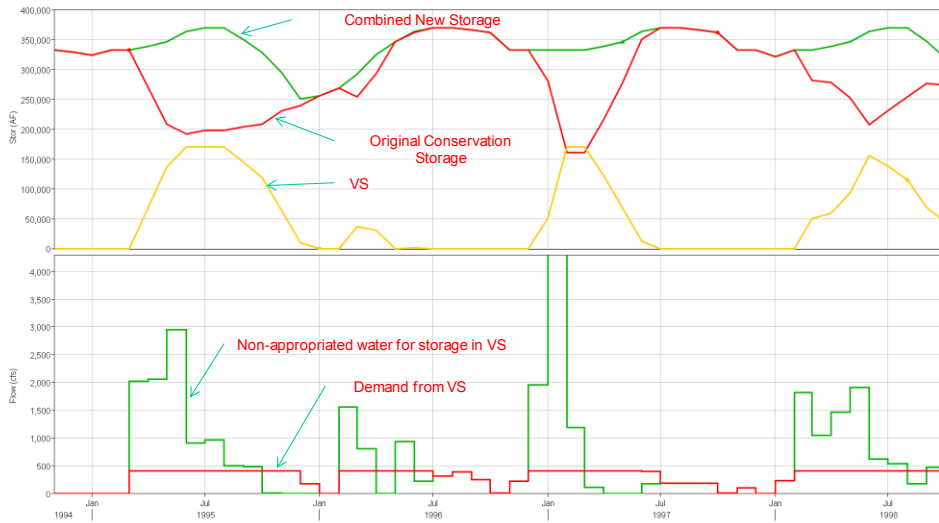
- VS management
  - a. Priorities for filling VS: LB first, P second
  - b. Each VS has a water contract (demand schedule)
  - c. Contract could serve multiple users
- Diversion points
  - a. Amador Canal (Node 12)
  - b. Pardee - Generic diversion point
  - c. Pardee – to Duck Creek (original MORE configuration)
  - d. Lower Mokelumne (assumed immediately below Camanche Dam)
- Diversion priorities
  - a. Top to bottom (LB, P, LM, DC)

The following chart (Figure 19) illustrates how the expanded MOCASIM tracks the storage in the enlarged Pardee Reservoir. The model “knows” at any given time what portion of the total volume of water in Pardee is “old” and what is “new”. The “new” water is stored or withdrawn from the VS depending on supply (of non-appropriated water) and demand (of VS users). Accordingly, the VS portion in Pardee can increase or decrease in size (not to exceed the total new addition of storage in the reservoir). The chart also shows that when VS storage diminishes (as a result of demand by VS users), the available space can be occupied by “old” water. This is merely due to the fact that Pardee “old” inflow can now be stored in the enlarged Pardee reservoir instead of being discharged for storage in Camanche.

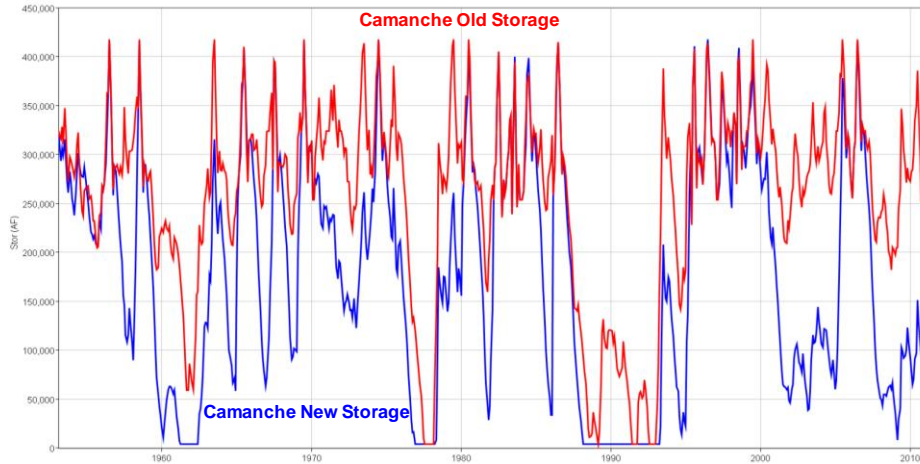
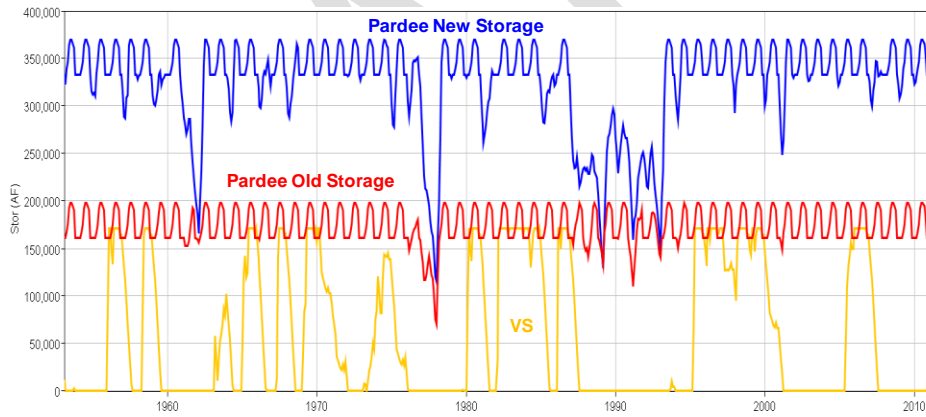
The outcome of this type of operation is that in many years Pardee will be fuller than historically occurred and Camanche will be emptier (as illustrated in the lower chart). This is consistent with the flood control rules that allow dividing flood space at any proportion between Pardee and Camanche. For EBMUD, this type of operation is advantageous as it has access to more volume of water to serve its customers since that the intake to the Mokelumne Aqueduct is situated in Pardee.

The same principles in the above example are applied for the Enlarged Lower Bear alternative.

**Figure 19 - Illustration of VS Concepts in Pardee Reservoir**



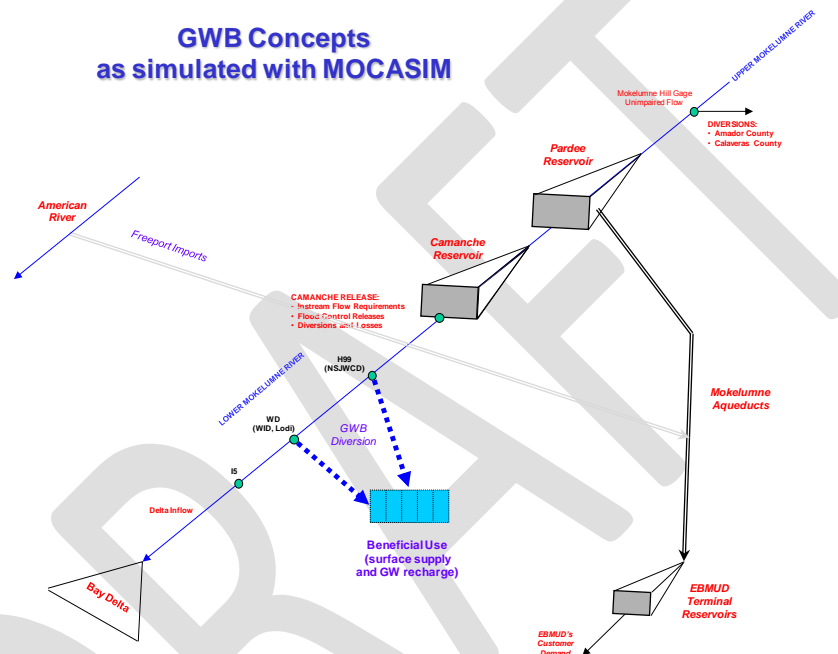
Enlarged Pardee Operation using VS concepts  
 VS is the portion of storage in Pardee due to the enlargement of the reservoir where non-appropriated water can be deposited to and withdrawn from.



### 5.3 Groundwater Banking (GWB)

Another feature in MOCASIM is the ability to analyze the potential benefit from banking in Eastern San Joaquin County the unused remaining water entitlement of upstream water users (Calaveras and/or Amador counties). This is a non-structural alternative that merely represents diversion of water to percolation ponds in the Lower Mokelumne basin via existing diversion facilities at NSJWCD and WID diversion structures, as illustrated in Figure 20 below.

**Figure 20 - GWB Diversion along the Lower Mokelumne**



Special logic was added to the model in the spirit of keeping existing users whole, as described in System Operation above:

- GWB diversion is curtailed if this action is the sole reason for EBMUD to start imposing rationing on its customers.
- GWB diversion is curtailed if this action is the sole reason for EBMUD to start importing water from the American River.
- All existing water rights, agreements, operational rules and instream flow requirements in the basin remain unchanged.

## 6 Conclusion

In conclusion, MOCASIM is a powerful tool that will be used for the MokeWISE Program to identify:

- What is the size of the water supply "pie" (current conditions)
- How the water supply "pie" is sliced (establish base case(s))

- What is the remaining “pie” that could be divided amongst the stakeholders (non-appropriated water)
- What new projects should be considered for implementation (structural and non-structural)
- What is the yield associated with each one of them (given certain sequence of implementation)

DRAFT

## **Appendix D: Annual Flow as Modeled in MOCASIM**

Appendix D shows the annual flow duration curves at four locations along the river. Flow duration curves indicate the percentage of time over the period of record that flow in the river would be expected to be equal to or exceed a certain amount of water, based on historical hydrologic conditions and projected diversion levels. Results indicate that total flow decreases downstream and that there is projected to be less flow in 2040 than in 2010 due to increased diversions.



### *Annual Flow*

The following figures show the annual flow duration curves for each of the four locations along the river. Flow duration curves indicate the percentage of time over the period of record that flow in the river is expected to be equal to or exceed a certain amount of water, based on historical hydrologic conditions and projected diversion levels.

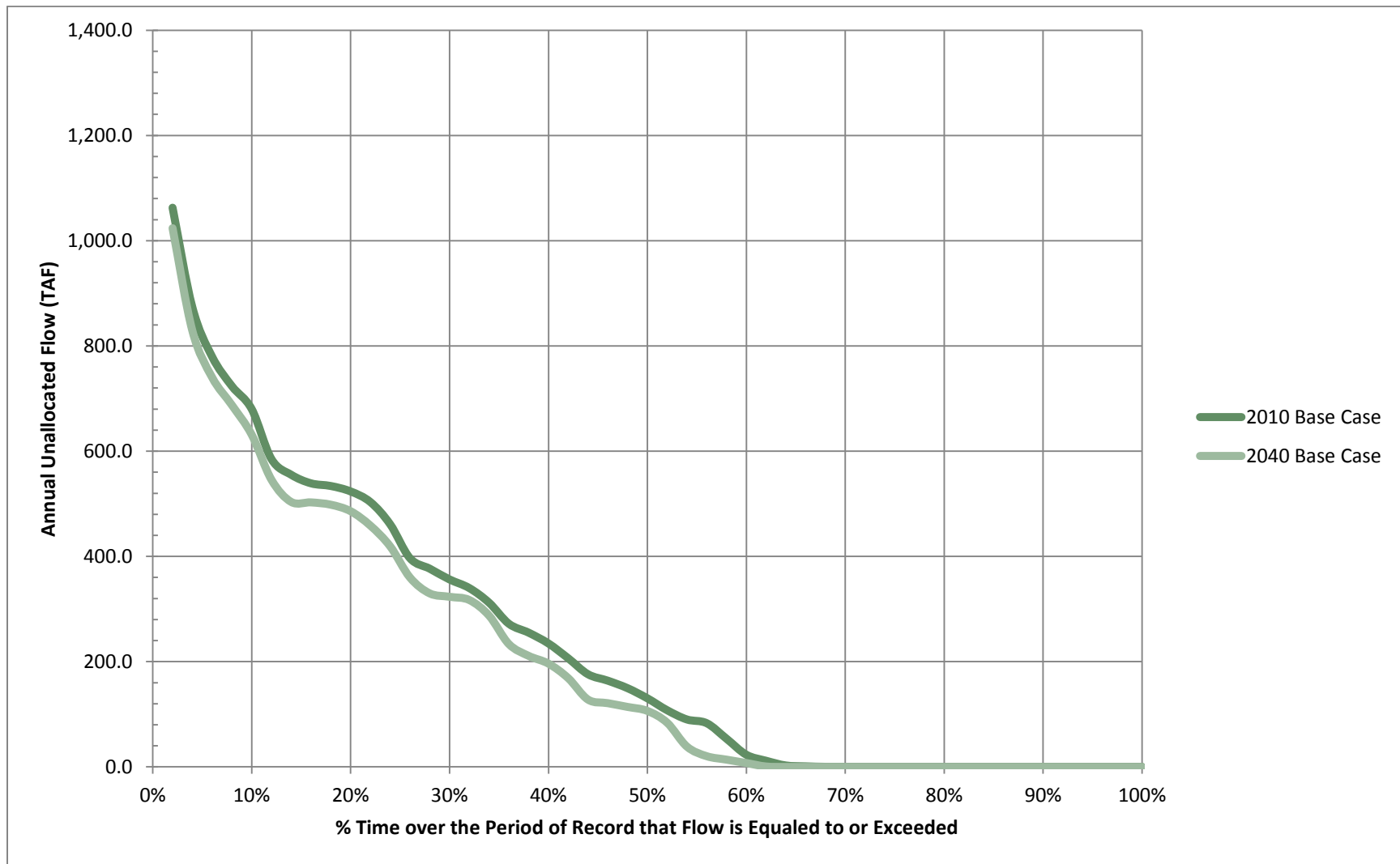
Flow duration curves for each location under 2010 and 2040 baseline diversion assumptions are presented in Figure D-1, Figure D-2, Figure D-3, and Figure D-4. Note that the unallocated flow curve is presented for below Camanche and total flow curves are presented for the remaining three nodes. The figures indicate that total flow decreases downstream.

Unallocated water at the nodes below Highway 99, below Woodbridge Dam, and below Interstate 5 is the same as the unallocated water at the below Camanche Dam node. This is due in part to MOCASIM acting as a mass balance model. Unallocated water released from Camanche Dam is calculated after all diversions and riparian diverter needs are met, as well as after any system losses that can be expected to occur (modeled riparian diversions are presented in Appendix I). The model assumes that this amount of unallocated water will be available for use at any point downstream of Camanche Dam, including below Highway 99, below Woodbridge Dam, and below Interstate 5.<sup>1</sup> System losses are included in the total release from Camanche and are not deducted from the unallocated portion.

---

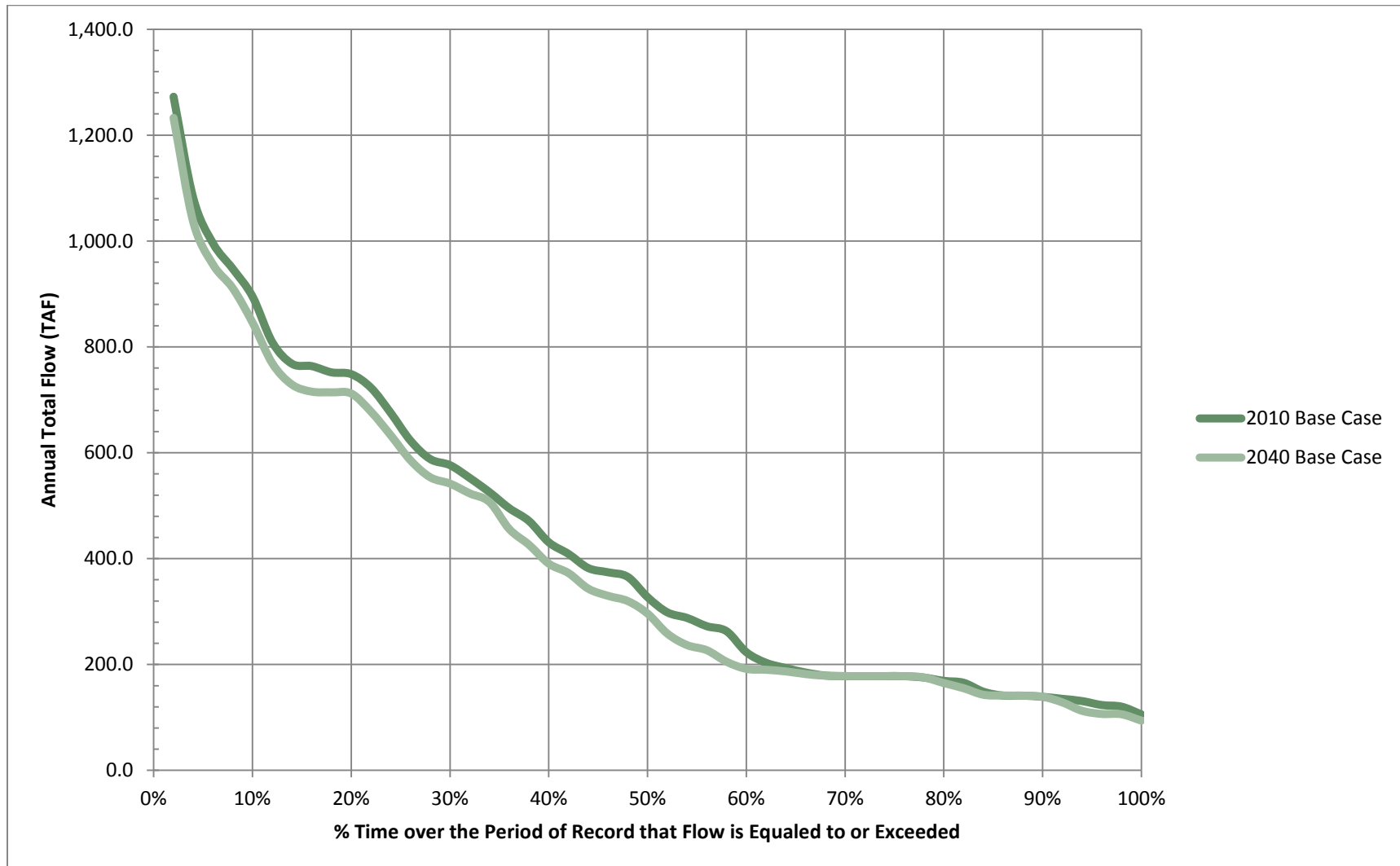
<sup>1</sup> Any project considered in MokeWISE that proposes diverting water upstream will affect unallocated water in that and all downstream reaches.

Figure D-1: Flow Duration Curve for Annual Unallocated Flow below Camanche Reservoir\*



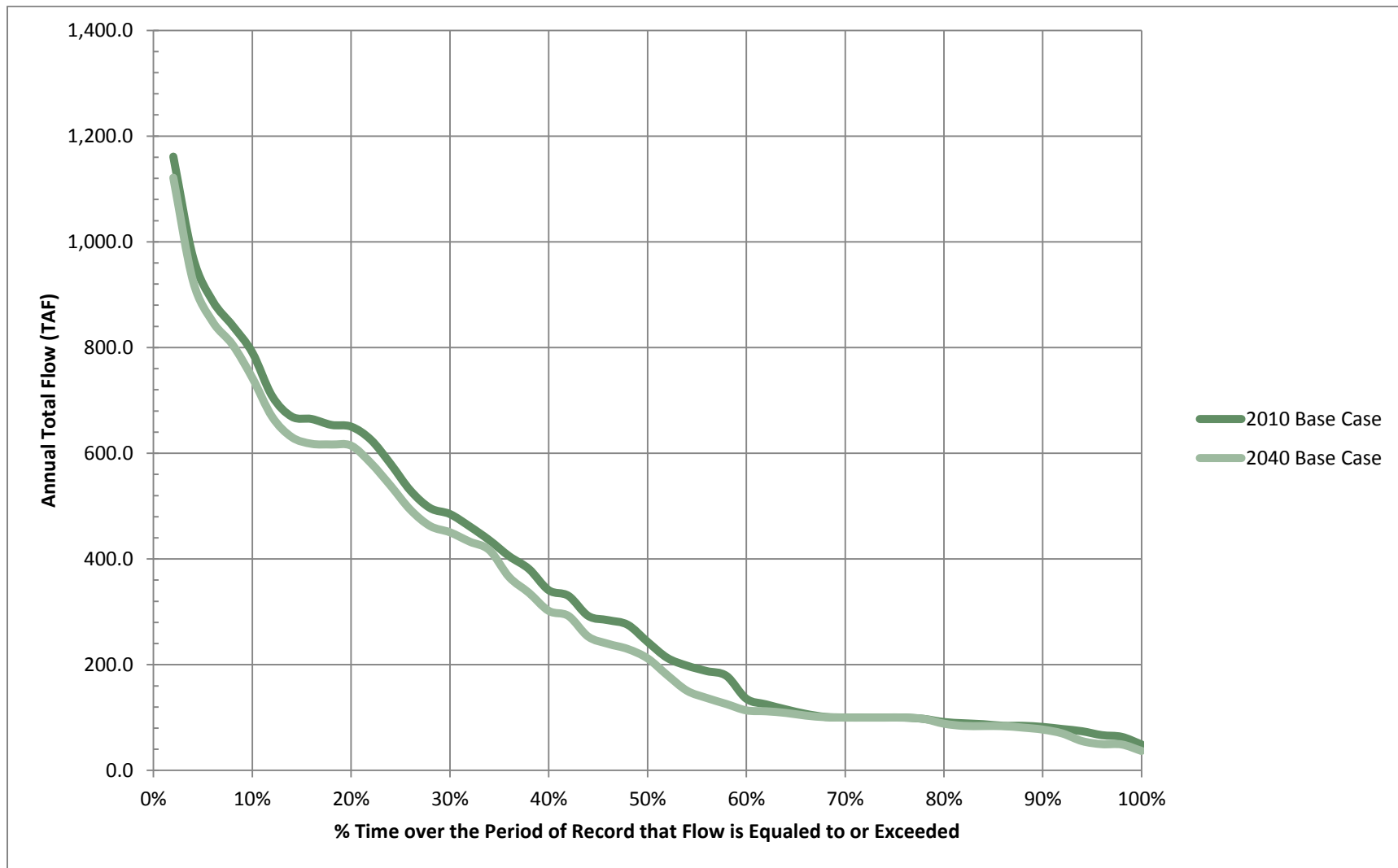
\* Flow duration curves indicate the percentage of time that flow in the River is expected to be equal to or exceed a certain amount of water.

Figure D-2: Flow Duration Curve for Annual Total Flow below Highway 99\*



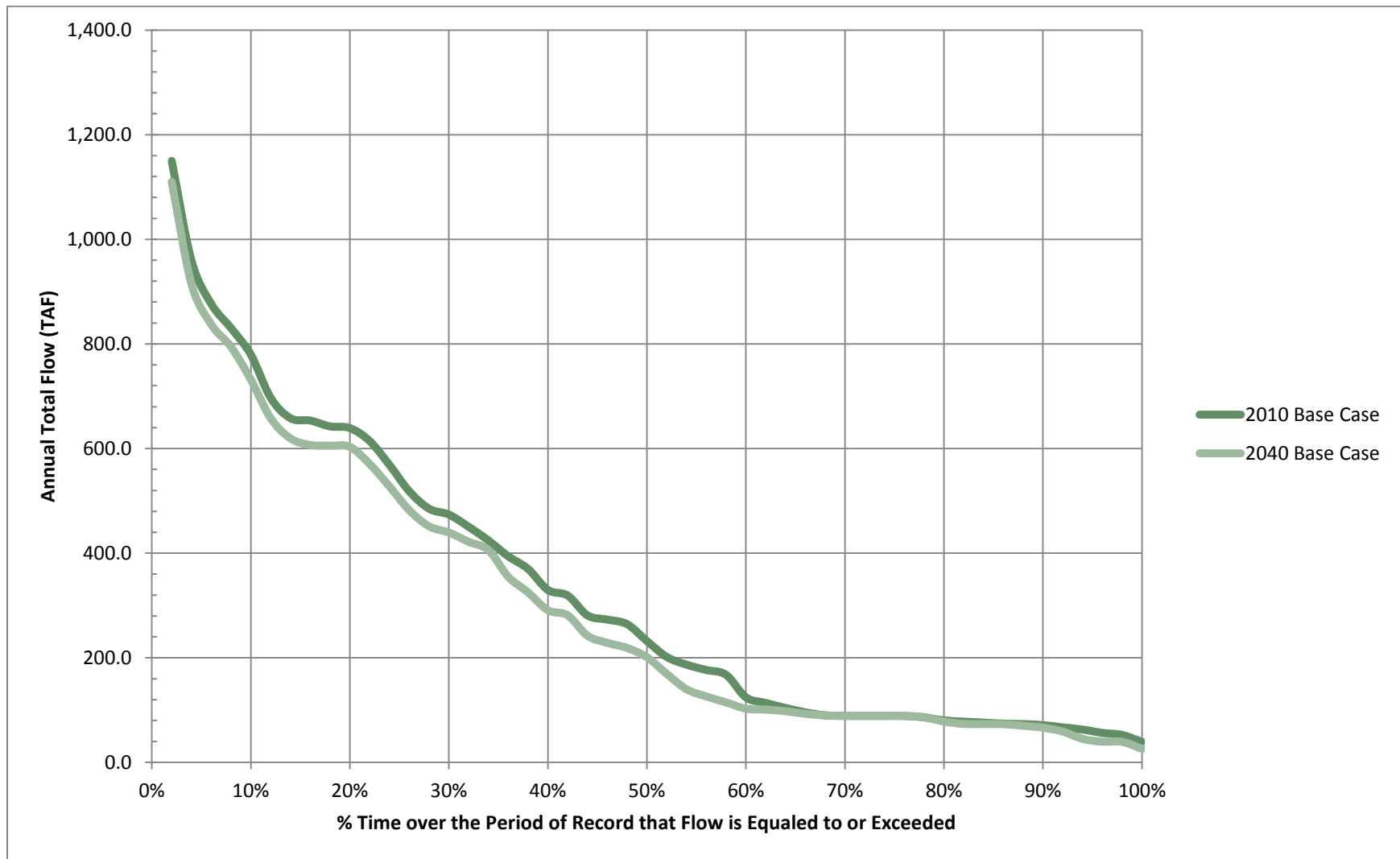
\* Flow duration curves indicate the percentage of time that flow in the River is expected to be equal to or exceed a certain amount of water.

Figure D-3: Flow Duration Curve for Annual Total Flow below Woodbridge Diversion Dam\*



\* Flow duration curves indicate the percentage of time that flow in the River is expected to be equal to or exceed a certain amount of water.

Figure D-4: Flow Duration Curve for Annual Total Flow below Interstate 5\*



\* Flow duration curves indicate the percentage of time that flow in the River is expected to be equal to or exceed a certain amount of water.

## **Appendix E: Monthly Flow as Modeled in MOCASIM**

Appendix E shows monthly unallocated flow alongside regulated flow and unimpaired flow for the full period of historical hydrology as simulated by the model. This appendix also shows flow distributions by month for five different hydrologic year types, at selected threshold flow levels. Results indicate that there is generally more unallocated flow in wetter years, and that there is a higher likelihood for unallocated flows occurring in the months from January to June compared with the months from July to December. Results also show less unallocated flows in 2040 than in 2010 due to increased diversions.

**Monthly Flow**

Water year types from the San Joaquin Valley Index were used to determine annual total flows in a given year type. The Index is based on measured unimpaired runoff and includes five water year types, including wet, above normal, below normal, dry, and critically dry (DWR 2013). The frequency of each water year type in the San Joaquin Valley Index is shown in Table E-1.

**Table E-1: Frequency of San Joaquin Valley Index Water Year Types within MOCASIM Period of Record**

<b>San Joaquin Valley Index Water Year Type</b>	<b>Frequency within MOCASIM Period of Record (Total Number)</b>	<b>Frequency within MOCASIM Period of Record (Percentage)</b>
<b>Wet</b>	19	33%
<b>Above Normal</b>	8	14%
<b>Below Normal</b>	8	14%
<b>Dry</b>	10	17%
<b>Critically Dry</b>	13	22%
<b>TOTAL</b>	58	100%

The tables below show flow distributions by month for five different hydrologic year types, at selected threshold flow levels. Table E-2 and Table E-3 indicate the percentage of months over the period of record when unallocated water is greater than 25,000 AF (345 cfs) below Camanche under the 2010 and 2040 baselines, respectively. The amount of unallocated water below Camanche is the same as the amount of unallocated water at the Highway 99, Woodbridge Dam, and Interstate 5 nodes, as noted earlier. Results indicate that there is more unallocated flow in wetter years; in those wetter years, the months from January through May are generally the most likely to have greater unallocated flows.

**Table E-2: Percentage of Months when Unallocated Water below Camanche is >25,000 AF (2010)**

<b>Year Type</b>	<b>Jan</b>	<b>Feb</b>	<b>Mar</b>	<b>Apr</b>	<b>May</b>	<b>Jun</b>	<b>Jul</b>	<b>Aug</b>	<b>Sep</b>	<b>Oct</b>	<b>Nov</b>	<b>Dec</b>
<b>Wet</b>	53%	74%	63%	53%	89%	89%	89%	89%	89%	0%	11%	21%
<b>Above Normal</b>	38%	75%	38%	0%	75%	63%	75%	75%	63%	0%	25%	38%
<b>Below Normal</b>	13%	0%	0%	0%	13%	13%	13%	13%	13%	0%	0%	0%
<b>Dry</b>	0%	0%	0%	0%	0%	0%	0%	0%	0%	0%	0%	30%
<b>Critically Dry</b>	0%	0%	0%	0%	0%	0%	0%	0%	0%	0%	0%	0%

**Table E-3: Percentage of Months when Unallocated Water below Camanche is >25,000 AF (2040)**

<b>Year Type</b>	<b>Jan</b>	<b>Feb</b>	<b>Mar</b>	<b>Apr</b>	<b>May</b>	<b>Jun</b>	<b>Jul</b>	<b>Aug</b>	<b>Sep</b>	<b>Oct</b>	<b>Nov</b>	<b>Dec</b>
Wet	47%	63%	63%	47%	84%	79%	79%	79%	79%	0%	11%	21%
Above Normal	25%	75%	38%	0%	25%	25%	25%	25%	25%	0%	13%	38%
Below Normal	13%	0%	0%	0%	0%	0%	0%	0%	0%	0%	0%	0%
Dry	0%	0%	0%	0%	0%	0%	0%	0%	0%	0%	0%	30%
Critically Dry	0%	0%	0%	0%	0%	0%	0%	0%	0%	0%	0%	0%

Table E-4 and Table E-5 indicate the percentage of months over the period of record when unallocated water is greater than 50,000 AF (690 cfs) below Camanche under the 2010 and 2040 baselines, respectively.

**Table E-4: Percentage of Months when Unallocated Water below Camanche is >50,000 AF (2010)**

<b>Year Type</b>	<b>Jan</b>	<b>Feb</b>	<b>Mar</b>	<b>Apr</b>	<b>May</b>	<b>Jun</b>	<b>Jul</b>	<b>Aug</b>	<b>Sep</b>	<b>Oct</b>	<b>Nov</b>	<b>Dec</b>
Wet	47%	47%	42%	42%	84%	53%	42%	42%	32%	0%	11%	21%
Above Normal	25%	38%	0%	0%	13%	13%	0%	0%	0%	0%	13%	13%
Below Normal	0%	0%	0%	0%	0%	0%	0%	0%	0%	0%	0%	0%
Dry	0%	0%	0%	0%	0%	0%	0%	0%	0%	0%	0%	30%
Critically Dry	0%	0%	0%	0%	0%	0%	0%	0%	0%	0%	0%	0%

**Table E-5: Percentage of Months when Unallocated Water below Camanche is >50,000 AF (2040)**

<b>Year Type</b>	<b>Jan</b>	<b>Feb</b>	<b>Mar</b>	<b>Apr</b>	<b>May</b>	<b>Jun</b>	<b>Jul</b>	<b>Aug</b>	<b>Sep</b>	<b>Oct</b>	<b>Nov</b>	<b>Dec</b>
Wet	47%	47%	42%	42%	63%	47%	26%	26%	26%	0%	11%	21%
Above Normal	25%	38%	0%	0%	13%	0%	0%	0%	0%	0%	13%	13%
Below Normal	0%	0%	0%	0%	0%	0%	0%	0%	0%	0%	0%	0%
Dry	0%	0%	0%	0%	0%	0%	0%	0%	0%	0%	0%	30%
Critically Dry	0%	0%	0%	0%	0%	0%	0%	0%	0%	0%	0%	0%



Table E-6 and Table E-7 indicate the percentage of months over the period of record when unallocated water is greater than 100,000 AF (1,380 cfs) below Camanche under the 2010 and 2040 baselines, respectively.

**Table E-6: Percentage of Months when Unallocated Water below Camanche is >100,000 AF (2010)**

<b>Year Type</b>	<b>Jan</b>	<b>Feb</b>	<b>Mar</b>	<b>Apr</b>	<b>May</b>	<b>Jun</b>	<b>Jul</b>	<b>Aug</b>	<b>Sep</b>	<b>Oct</b>	<b>Nov</b>	<b>Dec</b>
Wet	26%	32%	16%	21%	47%	5%	5%	5%	0%	0%	5%	11%
Above Normal	13%	0%	0%	0%	0%	0%	0%	0%	0%	0%	0%	0%
Below Normal	0%	0%	0%	0%	0%	0%	0%	0%	0%	0%	0%	0%
Dry	0%	0%	0%	0%	0%	0%	0%	0%	0%	0%	0%	20%
Critically Dry	0%	0%	0%	0%	0%	0%	0%	0%	0%	0%	0%	0%

**Table E-7: Percentage of Months when Unallocated Water below Camanche is >100,000 AF (2040)**

<b>Year Type</b>	<b>Jan</b>	<b>Feb</b>	<b>Mar</b>	<b>Apr</b>	<b>May</b>	<b>Jun</b>	<b>Jul</b>	<b>Aug</b>	<b>Sep</b>	<b>Oct</b>	<b>Nov</b>	<b>Dec</b>
Wet	26%	32%	16%	21%	47%	5%	0%	0%	0%	0%	5%	11%
Above Normal	13%	13%	0%	0%	0%	0%	0%	0%	0%	0%	0%	0%
Below Normal	0%	0%	0%	0%	0%	0%	0%	0%	0%	0%	0%	0%
Dry	0%	0%	0%	0%	0%	0%	0%	0%	0%	0%	0%	20%
Critically Dry	0%	0%	0%	0%	0%	0%	0%	0%	0%	0%	0%	0%

The following tables show monthly unallocated flow alongside regulated flow and unimpaired flow for the full period of historical hydrology as simulated by the model. The unallocated flow is represented at the node below Camanche, while the regulated and unimpaired flows are simulated at the Mokelumne Hill gage. The regulated flow simulates PG&E operations upstream and the unimpaired flow simulates the natural flow of the Mokelumne River at the Mokelumne Hill gage, assuming no upstream impairments or diversions. Table E-8 and Table E-9 present this information for the 2010 baseline, with Table E-8 showing the months January through July and Table E-9 showing August through December. Table E-10 and Table E-11 show the 2040 baseline; Table E-10 shows January through July and Table E-11 shows August through December. Regulated flow and natural flow are the same under both baseline cases; unallocated flow is the variable factor. Results indicate that there is generally more unallocated flow from January to May, and that there is more unallocated flow in the 2010 baseline than in the 2040 baseline due to increased diversions in 2040.

Table E-8: Unallocated, Regulated, and Natural Flow Comparison for January through July below Camanche (2010) (in TAF)\*

	January			February			March			April			May			June			July		
	Unallocated	Regulated	Natural	Unallocated	Regulated	Natural	Unallocated	Regulated	Natural	Unallocated	Regulated	Natural	Unallocated	Regulated	Natural	Unallocated	Regulated	Natural	Unallocated	Regulated	Natural
1953	24.7	60.9	68.6	0.0	41.0	31.9	0.0	45.0	51.5	0.0	62.2	131.1	23.3	76.1	151.6	22.5	124.5	159.1	23.3	55.3	39.8
1954	0.0	38.3	26.0	0.0	37.9	37.3	0.0	56.7	88.6	0.0	73.4	158.2	0.5	88.7	163.9	0.5	42.5	42.6	0.5	32.5	13.5
1955	0.0	29.9	32.1	0.0	26.9	27.6	0.0	37.1	39.5	0.0	29.9	68.0	0.0	48.7	172.0	0.0	53.4	97.6	0.0	33.8	11.2
1956	167.0	179.0	207.3	53.6	98.8	77.7	7.1	95.6	78.4	1.6	97.6	118.0	113.5	192.2	276.0	66.4	197.0	205.4	42.9	51.6	42.3
1957	0.0	36.5	15.0	0.0	40.8	56.8	0.0	49.0	91.2	0.0	42.2	91.7	11.2	93.6	180.3	10.8	129.5	133.7	11.2	33.9	14.7
1958	0.0	48.1	26.0	47.9	80.1	87.2	48.0	94.2	103.9	95.2	142.7	197.3	133.5	201.3	353.0	71.4	215.4	222.4	48.3	62.0	52.7
1959	0.0	39.4	31.6	0.0	44.8	42.5	0.0	40.7	54.5	0.0	24.1	99.2	0.0	26.8	91.2	0.0	31.0	35.2	0.0	32.9	3.0
1960	0.0	20.5	8.4	0.0	34.2	50.0	0.0	31.1	76.3	0.0	31.2	105.8	0.0	57.9	123.1	0.0	54.1	42.1	0.0	31.5	3.7
1961	0.0	23.3	7.8	0.0	15.2	19.6	0.0	17.6	29.4	0.0	18.5	73.1	0.0	22.1	105.4	0.0	30.3	33.9	0.0	31.2	1.4
1962	0.0	20.7	8.8	0.0	54.7	73.3	0.0	50.8	50.2	0.0	87.4	175.0	0.0	69.3	164.3	0.0	131.6	140.3	0.0	39.4	17.0
1963	0.0	47.0	43.4	62.3	82.6	170.0	0.0	46.3	45.9	0.0	104.9	130.8	77.3	215.0	270.8	50.4	139.9	140.7	37.9	42.2	27.5
1964	0.0	47.1	24.9	0.0	37.1	22.2	0.0	34.0	31.7	0.0	31.9	85.4	0.0	32.6	145.4	0.0	33.9	70.2	0.0	36.6	8.9
1965	128.3	161.7	155.2	35.1	86.4	72.5	0.0	73.8	63.6	12.2	113.9	162.4	50.7	134.9	205.2	49.1	161.9	168.7	50.7	57.4	45.9
1966	2.7	41.1	23.5	0.0	23.4	22.9	0.0	42.3	69.5	0.0	51.7	136.4	0.0	46.5	126.8	0.0	27.3	45.2	0.0	33.4	4.4
1967	25.7	68.0	64.7	16.3	54.8	58.1	48.8	99.8	123.0	55.0	109.4	116.5	165.1	162.7	297.0	60.0	250.5	298.3	62.0	128.9	124.9
1968	0.0	39.2	20.2	0.0	46.0	72.5	0.0	45.8	62.5	0.0	37.8	87.5	0.0	30.1	115.9	0.0	38.0	35.9	0.0	31.1	3.9
1969	149.1	162.2	201.9	78.2	103.6	105.8	39.8	97.4	89.0	123.6	148.9	210.8	176.8	282.9	382.6	67.8	220.6	233.8	51.9	71.9	61.5
1970	195.8	162.2	242.7	42.7	84.6	80.7	16.4	100.0	85.4	0.0	67.8	76.0	15.4	115.7	187.2	14.9	120.3	117.6	15.4	45.7	18.4
1971	26.9	65.2	57.0	17.5	61.5	49.2	17.8	77.5	72.5	0.0	73.3	108.0	26.4	66.7	170.9	25.6	129.1	181.9	26.4	59.9	31.6
1972	0.0	36.7	20.4	0.0	29.8	32.8	0.0	57.5	100.1	0.0	49.1	80.3	0.0	39.7	160.7	0.0	71.5	67.9	0.0	38.4	7.0
1973	45.6	76.9	79.6	57.0	79.3	75.5	27.5	79.5	68.8	0.0	77.6	126.3	28.9	138.0	279.8	27.9	102.5	108.0	28.9	46.9	10.1
1974	68.3	91.3	113.3	0.0	63.6	37.5	38.6	118.0	122.4	25.7	114.6	141.3	50.5	140.4	250.4	42.9	140.8	148.9	44.3	62.2	35.7
1975	0.0	28.3	17.9	0.0	37.2	41.8	0.0	75.1	85.4	0.0	73.4	71.4	50.7	108.8	256.2	49.0	178.1	233.6	50.7	67.6	41.5
1976	0.0	28.2	10.0	0.0	13.5	13.8	0.0	16.4	28.2	0.0	16.9	44.3	0.0	18.6	71.8	0.0	17.0	7.9	0.0	17.1	1.4
1977	0.0	11.1	4.0	0.0	6.0	6.5	0.0	7.5	9.2	0.0	13.7	35.9	0.0	18.3	43.1	0.0	16.2	25.4	0.0	16.9	1.6
1978	0.0	72.3	88.6	0.0	65.6	61.3	0.0	97.0	129.4	0.0	114.0	152.4	20.3	113.4	238.0	19.6	191.2	215.7	20.3	67.6	50.6
1979	0.0	49.1	47.6	5.7	49.2	47.3	22.8	81.6	94.3	0.1	86.5	120.8	25.6	118.6	261.8	24.8	92.2	94.3	25.6	39.5	12.2
1980	178.1	167.4	248.4	124.3	153.8	167.7	17.6	114.2	99.2	0.0	87.3	132.8	55.4	133.4	203.2	47.5	170.9	175.4	49.1	78.9	68.3
1981	0.0	42.0	18.6	0.0	34.8	27.0	0.0	34.7	47.0	0.0	41.6	111.0	0.0	32.0	126.4	0.0	32.3	32.1	0.0	34.5	0.4
1982	79.1	109.5	102.2	155.0	166.3	206.4	99.4	156.6	154.0	198.6	245.2	303.4	153.0	287.3	314.1	60.6	182.0	186.5	62.7	78.9	55.5
1983	70.6	119.3	102.1	113.7	150.9	144.3	198.8	243.3	267.9	93.3	140.3	142.9	237.8	210.7	320.3	169.8	372.4	379.9	100.7	209.2	206.4
1984	77.3	114.4	87.5	37.4	88.3	56.3	8.2	96.8	85.0	0.0	80.1	86.6	30.3	145.4	217.8	29.3	109.8	99.2	30.3	58.9	17.7
1985	0.0	24.6	15.8	0.0	35.4	28.0	0.0	51.2	41.6	0.0	62.2	129.6	0.0	32.9	142.0	0.0	30.6	34.2	0.0	31.3	4.3
1986	0.0	52.9	69.0	285.4	266.4	340.3	157.4	192.4	259.8	8.0	125.1	142.2	80.5	194.1	214.1	34.4	133.2	142.6	35.5	45.8	24.5
1987	0.0	25.7	7.9	0.0	17.9	21.2	0.0	25.3	41.7	0.0	22.4	85.1	0.0	17.8	79.8	0.0	22.2	11.6	0.0	33.2	2.2
1988	0.0	22.1	17.9	0.0	14.9	20.1	0.0	17.5	41.5	0.0	19.3	67.7	0.0	23.5	68.3	0.0	27.5	22.6	0.0	28.9	3.7
1989	0.0	13.9	11.0	0.0	15.1	24.9	0.0	61.0	144.9	0.0	81.5	151.8	0.0	106.7	130.3	0.0	70.7	63.3	0.0	35.4	6.4
1990	0.0	33.3	17.3	0.0	22.8	18.5	0.0	33.3	59.2	0.0	24.4	97.6	0.0	33.4	72.1	0.0	34.7	33.9	0.0	33.4	3.6
1991	0.0	4.9	3.6	0.0	8.2	4.0	0.0	22.9	51.5	0.0	26.4	66.8	0.0	30.9	133.6	0.0	44.2	79.7	0.0	34.1	8.8

Table E-8: Unallocated, Regulated, and Natural Flow Comparison for January through July below Camanche (2010) (in TAF)\*

	January			February			March			April			May			June			July		
	Unallocated	Regulated	Natural	Unallocated	Regulated	Natural	Unallocated	Regulated	Natural	Unallocated	Regulated	Natural	Unallocated	Regulated	Natural	Unallocated	Regulated	Natural	Unallocated	Regulated	Natural
1992	0.0	23.4	10.1	0.0	29.3	41.6	0.0	39.9	53.8	0.0	24.6	107.6	0.0	21.7	56.9	0.0	18.7	8.5	0.0	30.9	8.8
1993	0.0	76.0	105.2	0.0	73.8	69.3	0.0	120.7	155.3	0.0	104.0	149.5	35.8	177.1	272.9	34.7	177.8	190.2	35.8	53.7	43.2
1994	0.0	20.8	9.9	0.0	16.2	17.3	0.0	18.8	43.5	0.0	17.7	78.0	0.0	22.3	94.2	0.0	29.4	27.9	0.0	24.1	2.2
1995	0.0	109.9	144.9	33.2	73.4	73.1	167.0	204.0	253.4	138.0	164.4	188.9	242.1	250.6	332.3	89.5	302.8	317.2	78.3	182.9	194.8
1996	0.0	44.6	54.7	111.1	114.2	165.9	52.9	130.0	131.8	9.2	119.1	152.9	92.0	228.0	259.8	27.8	114.0	117.3	28.7	45.7	25.0
1997	359.2	348.8	442.7	74.9	112.6	87.1	12.8	94.8	85.0	0.0	95.2	124.3	12.7	148.2	174.9	12.3	81.9	69.8	12.7	39.8	11.2
1998	23.5	62.6	82.6	106.1	123.7	141.1	67.3	127.2	159.7	88.1	124.0	159.2	139.6	161.6	223.2	74.8	282.8	349.3	67.7	135.4	137.7
1999	20.9	69.2	61.2	90.4	119.9	130.9	29.0	90.7	83.3	0.0	87.2	112.5	41.3	123.8	244.8	46.2	155.1	166.0	39.2	59.9	28.3
2000	0.0	51.0	62.2	48.4	82.8	113.4	26.9	94.1	95.7	0.0	68.2	134.6	18.4	128.5	207.2	17.8	83.4	69.2	18.4	51.5	9.9
2001	0.0	19.8	12.8	0.0	18.2	20.9	0.0	38.2	63.9	0.0	54.0	89.7	0.0	44.7	140.3	0.0	32.5	12.3	0.0	34.5	4.1
2002	0.0	54.1	43.5	0.0	36.5	36.8	0.0	69.8	66.2	0.0	66.1	132.0	0.0	53.6	161.1	0.0	61.4	62.6	0.0	32.0	10.3
2003	0.0	57.2	38.2	0.1	49.7	33.2	0.0	48.2	57.0	0.0	59.8	96.6	16.7	105.9	216.4	16.2	123.8	132.3	16.7	36.1	16.2
2004	0.0	51.8	22.8	3.2	50.1	49.0	13.0	78.7	111.1	0.0	47.3	121.6	0.0	28.5	116.1	0.0	47.8	30.1	0.0	32.7	4.5
2005	0.0	83.9	72.3	31.9	78.3	65.1	67.6	123.8	118.6	29.6	122.1	125.6	95.3	181.1	320.3	54.3	169.7	198.7	40.0	73.5	49.8
2006	90.0	109.9	141.8	49.8	79.9	95.9	65.7	159.7	131.5	230.8	292.0	312.7	146.7	293.6	356.4	65.9	191.0	191.7	32.7	70.6	33.2
2007	0.0	32.8	18.2	0.0	35.7	53.7	0.0	46.7	74.5	0.0	29.0	98.7	0.0	35.6	95.8	0.0	28.4	17.3	0.0	32.2	6.8
2008	0.0	29.8	22.2	0.0	30.9	27.9	0.0	46.5	50.6	0.0	28.9	82.8	0.0	40.5	143.0	0.0	35.5	51.2	0.0	24.3	5.6
2009	0.0	42.0	31.8	0.0	38.5	45.3	0.0	79.8	103.0	0.0	69.8	113.5	5.0	159.9	243.1	4.8	57.7	54.1	5.0	39.9	9.8
2010	0.0	45.7	26.7	0.0	42.6	31.0	0.0	59.3	58.7	0.0	81.6	103.8	31.6	117.0	170.5	30.6	133.0	235.6	31.6	48.7	30.4

\* Unallocated water is simulated below Camanche and regulated and unimpaired flow is simulated at Mokelumne Hill.

**Table E-9: Unallocated, Regulated, and Natural Flow Comparison for August through December below Camanche (2010) (in TAF)\***

	August			September			October			November			December			Total		
	Unallocated	Regulated	Natural	Unallocated	Regulated	Natural	Unallocated	Regulated	Natural	Unallocated	Regulated	Natural	Unallocated	Regulated	Natural	Unallocated	Regulated	Natural
1953	23.3	37.5	4.0	22.5	38.0	2.2	0.0	42.1	5.7	0.0	39.3	11.4	0.0	38.0	14.7	139.5	660.0	671.5
1954	0.5	34.9	0.0	0.5	36.8	2.3	0.0	38.1	4.1	0.0	41.0	7.9	0.0	34.7	28.6	2.4	555.4	572.9
1955	0.0	34.4	2.8	0.0	32.6	0.9	0.0	33.7	2.4	0.0	33.8	5.8	121.0	163.3	259.8	121.0	557.5	719.6
1956	42.9	37.0	6.5	41.5	34.4	4.4	0.0	40.1	9.1	0.0	43.0	10.7	0.0	45.2	13.2	536.6	1,111.5	1,049.0
1957	11.2	31.5	2.4	10.8	32.4	2.3	0.0	39.8	4.0	0.0	43.6	7.2	0.0	43.6	16.1	55.3	616.3	615.6
1958	48.3	44.9	8.7	46.7	35.9	3.7	0.0	40.0	3.9	0.0	38.3	5.5	0.0	33.8	5.0	539.1	1,036.7	1,069.3
1959	0.0	32.7	0.1	0.0	30.9	4.6	0.0	32.6	2.2	0.0	30.6	1.9	0.0	32.2	3.3	0.0	398.7	369.4
1960	0.0	31.8	0.0	0.0	30.8	1.0	0.0	31.1	0.5	0.0	30.1	6.6	0.0	31.9	10.8	0.0	416.2	428.3
1961	0.0	30.1	0.0	0.0	30.1	0.3	0.0	31.0	0.4	0.0	19.1	3.8	0.0	18.8	10.4	0.0	287.5	285.4
1962	0.0	37.3	2.4	0.0	34.3	0.0	0.0	40.3	20.0	0.0	37.8	6.8	0.0	37.9	18.5	0.0	641.5	676.6
1963	37.9	38.9	2.8	36.7	36.6	3.4	0.0	38.2	7.0	23.0	41.7	46.4	0.0	43.7	23.9	325.5	876.8	912.8
1964	0.0	35.3	2.0	0.0	34.6	2.5	0.0	36.7	4.4	0.0	42.9	15.6	229.4	202.7	315.5	229.4	605.5	728.7
1965	50.7	45.4	20.9	49.1	56.1	7.0	0.0	56.1	5.3	19.2	57.0	26.5	2.8	46.5	21.9	447.8	1,051.1	955.1
1966	0.0	33.6	1.0	0.0	36.2	1.9	0.0	33.4	1.5	0.0	40.3	17.6	0.0	71.8	72.3	2.7	481.0	523.0
1967	62.0	40.5	14.0	60.0	38.5	5.3	0.0	39.6	5.4	0.0	39.9	7.1	0.0	40.2	11.0	554.8	1,072.9	1,125.3
1968	0.0	31.6	2.5	0.0	32.4	1.0	0.0	32.8	4.6	0.0	40.1	34.5	0.0	44.6	23.9	0.0	449.4	465.0
1969	51.9	50.0	7.0	50.3	46.7	3.7	0.0	48.5	11.1	0.0	39.7	11.8	9.9	54.8	65.7	799.4	1,327.3	1,384.7
1970	15.4	35.5	3.9	14.9	34.2	0.3	0.0	36.6	2.9	21.7	52.5	31.1	32.7	74.5	53.8	385.3	929.7	900.1
1971	26.4	54.5	3.4	25.6	41.5	0.5	0.0	44.4	3.2	4.9	33.3	12.1	7.3	41.5	29.8	204.8	748.2	720.0
1972	0.0	34.2	0.9	0.0	33.9	0.9	0.0	37.5	4.4	0.0	39.7	11.3	0.0	46.1	38.6	0.0	514.0	525.3
1973	28.9	34.7	1.5	27.9	34.8	0.0	0.0	38.8	6.3	64.4	54.9	85.6	39.2	76.0	73.8	376.3	839.7	915.3
1974	44.3	56.4	5.8	42.9	44.6	0.9	0.0	35.8	3.1	0.0	30.7	5.2	0.0	33.0	11.3	357.5	931.4	875.9
1975	50.7	55.7	7.4	49.0	52.9	2.9	0.0	45.8	21.9	4.6	41.6	22.9	0.0	39.0	12.0	254.8	803.5	814.9
1976	0.0	17.8	4.3	0.0	17.2	2.2	0.0	12.3	2.0	0.0	12.2	2.5	0.0	9.1	1.9	0.0	196.3	190.2
1977	0.0	16.4	1.4	0.0	17.5	1.4	0.0	1.1	0.8	0.0	2.9	3.4	0.0	23.7	29.5	0.0	151.4	162.2
1978	20.3	53.0	3.7	19.6	40.7	13.6	0.0	36.8	2.2	0.0	34.4	5.2	0.0	31.6	8.8	100.0	917.7	969.4
1979	25.6	36.1	3.1	24.8	32.0	0.2	0.0	34.8	9.0	0.0	38.9	18.1	0.0	48.4	19.9	155.1	707.0	728.5
1980	49.1	36.8	7.4	47.5	34.6	2.9	0.0	35.3	2.5	0.0	33.3	3.0	0.0	37.9	8.1	568.6	1,083.8	1,118.9
1981	0.0	28.6	0.5	0.0	30.1	0.5	0.0	35.0	5.6	0.0	45.0	78.2	87.2	83.4	132.6	87.2	474.1	579.8
1982	62.7	55.4	7.9	60.6	43.1	13.7	0.0	47.5	67.8	66.4	83.5	61.8	90.7	122.0	109.1	1,088.9	1,577.2	1,582.5
1983	100.7	70.0	31.0	97.4	57.6	16.8	0.0	56.1	10.4	122.3	116.2	160.1	151.3	179.5	188.4	1,456.5	1,925.7	1,970.6
1984	30.3	50.2	3.6	29.3	35.4	1.3	0.0	39.0	4.7	16.6	46.3	31.1	0.8	43.2	16.6	289.9	907.7	707.2
1985	0.0	34.5	1.5	0.0	34.1	2.7	0.0	37.1	1.9	0.0	39.6	11.8	0.0	39.8	25.2	0.0	453.3	438.6
1986	35.5	38.7	6.7	34.4	37.2	2.0	0.0	37.9	1.6	0.0	37.8	1.6	0.0	33.3	3.5	670.9	1,194.8	1,208.0
1987	0.0	32.3	0.7	0.0	28.6	0.7	0.0	15.1	1.8	0.0	13.8	2.0	0.0	18.2	3.5	0.0	272.6	258.2
1988	0.0	24.2	0.8	0.0	21.1	0.7	0.0	14.3	0.2	0.0	13.3	9.5	0.0	13.7	9.4	0.0	240.5	262.4
1989	0.0	32.2	1.8	0.0	33.8	3.7	0.0	24.1	10.2	0.0	36.9	12.8	0.0	35.6	10.3	0.0	546.9	571.2
1990	0.0	29.7	1.0	0.0	28.9	0.4	0.0	32.4	0.4	0.0	9.3	0.9	0.0	12.3	3.1	0.0	327.9	308.2

**Table E-9: Unallocated, Regulated, and Natural Flow Comparison for August through December below Camanche (2010) (in TAF)\***

	August			September			October			November			December			Total		
	Unallocated	Regulated	Natural	Unallocated	Regulated	Natural	Unallocated	Regulated	Natural	Unallocated	Regulated	Natural	Unallocated	Regulated	Natural	Unallocated	Regulated	Natural
1991	0.0	29.9	2.0	0.0	29.8	0.0	0.0	33.3	5.7	0.0	34.1	8.6	0.0	31.4	8.7	0.0	330.0	373.1
1992	0.0	30.2	1.2	0.0	20.3	2.2	0.0	20.0	2.2	0.0	15.4	5.4	0.0	24.6	18.7	0.0	299.0	316.9
1993	35.8	54.2	9.8	34.7	35.4	4.0	0.0	40.6	4.3	0.0	32.1	2.6	0.0	32.4	4.1	176.8	977.8	1,010.3
1994	0.0	26.5	1.3	0.0	33.3	1.1	0.0	33.4	2.9	0.0	14.5	15.2	0.0	32.9	20.5	0.0	290.1	314.0
1995	78.3	51.0	30.4	75.8	47.3	7.5	0.0	50.7	4.7	0.0	34.0	4.4	0.0	36.6	31.3	902.3	1,507.7	1,582.9
1996	28.7	44.7	6.1	27.8	34.8	2.4	0.0	33.3	0.0	18.1	53.3	40.4	129.3	141.5	161.8	525.7	1,103.3	1,118.0
1997	12.7	41.5	4.6	12.3	37.0	3.3	0.0	39.8	2.2	10.2	41.9	8.9	0.0	28.1	11.6	520.1	1,109.7	1,025.6
1998	67.7	58.8	15.9	65.6	50.1	8.1	0.0	42.8	7.5	0.8	41.9	17.7	0.0	49.4	25.4	701.3	1,260.3	1,327.4
1999	39.2	41.6	7.6	38.0	37.8	3.5	0.0	35.5	1.6	0.0	39.8	9.9	0.0	34.6	8.3	344.3	895.2	858.0
2000	18.4	43.5	1.6	17.8	33.3	4.2	0.0	34.7	5.2	0.0	36.4	6.3	0.0	34.8	5.6	166.2	742.3	715.1
2001	0.0	32.1	2.3	0.0	28.1	3.6	0.0	25.7	0.0	0.0	20.3	14.0	0.0	37.2	32.7	0.0	385.1	396.5
2002	0.0	31.5	1.7	0.0	30.0	0.0	0.0	32.0	1.2	0.0	34.2	20.0	0.0	40.8	22.7	0.0	542.0	558.1
2003	16.7	33.1	1.0	16.2	35.1	0.9	0.0	35.8	0.8	0.0	32.1	4.0	0.0	47.2	30.5	82.6	664.0	627.0
2004	0.0	34.2	0.3	0.0	31.0	0.0	0.0	17.6	9.7	0.0	33.0	11.8	0.0	45.3	24.6	16.1	498.1	501.5
2005	40.0	49.3	5.4	38.7	41.0	1.7	0.0	32.7	6.3	0.0	37.4	8.5	91.6	104.9	128.5	489.0	1,097.8	1,100.8
2006	32.7	53.4	7.1	31.6	31.9	4.6	0.0	34.4	6.3	2.7	37.1	14.4	3.4	45.7	20.1	751.9	1,399.2	1,315.6
2007	0.0	31.2	1.4	0.0	29.9	2.6	0.0	21.2	0.6	0.0	32.8	3.0	0.0	25.3	6.9	0.0	380.7	379.6
2008	0.0	28.8	2.6	0.0	20.7	3.2	0.0	31.0	0.2	0.0	32.3	13.6	0.0	28.8	7.7	0.0	377.9	410.6
2009	5.0	34.9	3.3	4.8	25.5	1.6	0.0	26.7	4.0	0.0	28.4	3.0	0.0	34.5	10.8	24.7	637.5	623.2
2010	31.6	28.7	2.2	30.6	20.9	1.4	0.0	42.2	31.8	25.1	40.2	25.2	74.4	120.0	123.4	255.4	779.9	840.7

\* Unallocated water is simulated below Camanche and regulated and unimpaired flow is simulated at Mokelumne Hill.

Table E-10: Unallocated, Regulated, and Natural Flow Comparison for January through July below Camanche (2040) (in TAF)\*

	January			February			March			April			May			June			July		
	Unallocated	Regulated	Natural	Unallocated	Regulated	Natural	Unallocated	Regulated	Natural	Unallocated	Regulated	Natural	Unallocated	Regulated	Natural	Unallocated	Regulated	Natural	Unallocated	Regulated	Natural
1953	23.3	60.9	68.6	0.0	41.0	31.9	0.0	45.0	51.5	0.0	62.2	131.1	16.5	76.1	151.6	16.0	124.5	159.1	16.5	55.3	39.8
1954	0.0	38.3	26.0	0.0	37.9	37.3	0.0	56.7	88.6	0.0	73.4	158.2	0.0	88.7	163.9	0.0	42.5	42.6	0.0	32.5	13.5
1955	0.0	29.9	32.1	0.0	26.9	27.6	0.0	37.1	39.5	0.0	29.9	68.0	0.0	48.7	172.0	0.0	53.4	97.6	0.0	33.8	11.2
1956	165.6	179.0	207.3	52.3	98.8	77.7	5.6	95.6	78.4	0.2	97.6	118.0	108.8	192.2	276.0	60.5	197.0	205.4	37.1	51.6	42.3
1957	0.0	36.5	15.0	0.0	40.8	56.8	0.0	49.0	91.2	0.0	42.2	91.7	4.0	93.6	180.3	3.9	129.5	133.7	4.0	33.9	14.7
1958	0.0	48.1	26.0	42.2	80.1	87.2	46.5	94.2	103.9	93.8	142.7	197.3	128.9	201.3	353.0	65.5	215.4	222.4	42.5	62.0	52.7
1959	0.0	39.4	31.6	0.0	44.8	42.5	0.0	40.7	54.5	0.0	24.1	99.2	0.0	26.8	91.2	0.0	31.0	35.2	0.0	32.9	3.0
1960	0.0	20.5	8.4	0.0	34.2	50.0	0.0	31.1	76.3	0.0	31.2	105.8	0.0	57.9	123.1	0.0	54.1	42.1	0.0	31.5	3.7
1961	0.0	23.3	7.8	0.0	15.2	19.6	0.0	17.6	29.4	0.0	18.5	73.1	0.0	22.1	105.4	0.0	30.3	33.9	0.0	31.2	1.4
1962	0.0	20.7	8.8	0.0	54.7	73.3	0.0	50.8	50.2	0.0	87.4	175.0	0.0	69.3	164.3	0.0	131.6	140.3	0.0	39.4	17.0
1963	0.0	47.0	43.4	105.9	82.6	170.0	0.0	46.3	45.9	0.0	104.9	130.8	64.0	215.0	270.8	43.9	139.9	140.7	31.6	42.2	27.5
1964	0.0	47.1	24.9	0.0	37.1	22.2	0.0	34.0	31.7	0.0	31.9	85.4	0.0	32.6	145.4	0.0	33.9	70.2	0.0	36.6	8.9
1965	126.9	161.7	155.2	33.8	86.4	72.5	0.0	73.8	63.6	9.1	113.9	162.4	45.4	134.9	205.2	43.6	161.9	168.7	45.0	57.4	45.9
1966	1.3	41.1	23.5	0.0	23.4	22.9	0.0	42.3	69.5	0.0	51.7	136.4	0.0	46.5	126.8	0.0	27.3	45.2	0.0	33.4	4.4
1967	4.4	68.0	64.7	15.1	54.8	58.1	47.3	99.8	123.0	53.7	109.4	116.5	160.6	162.7	297.0	54.5	250.5	298.3	56.3	128.9	124.9
1968	0.0	39.2	20.2	0.0	46.0	72.5	0.0	45.8	62.5	0.0	37.8	87.5	0.0	30.1	115.9	0.0	38.0	35.9	0.0	31.1	3.9
1969	142.3	162.2	201.9	77.0	103.6	105.8	38.5	97.4	89.0	122.2	148.9	210.8	172.2	282.9	382.6	61.9	220.6	233.8	46.2	71.9	61.5
1970	194.4	162.2	242.7	41.4	84.6	80.7	14.9	100.0	85.4	0.0	67.8	76.0	9.4	115.7	187.2	9.1	120.3	117.6	9.4	45.7	18.4
1971	25.5	65.2	57.0	16.2	61.5	49.2	16.3	77.5	72.5	0.0	73.3	108.0	20.3	66.7	170.9	19.6	129.1	181.9	20.3	59.9	31.6
1972	0.0	36.7	20.4	0.0	29.8	32.8	0.0	57.5	100.1	0.0	49.1	80.3	0.0	39.7	160.7	0.0	71.5	67.9	0.0	38.4	7.0
1973	22.8	76.9	79.6	55.7	79.3	75.5	26.0	79.5	68.8	0.0	77.6	126.3	23.2	138.0	279.8	22.5	102.5	108.0	23.2	46.9	10.1
1974	66.9	91.3	113.3	0.0	63.6	37.5	35.8	118.0	122.4	24.1	114.6	141.3	45.8	140.4	250.4	37.2	140.8	148.9	38.4	62.2	35.7
1975	0.0	28.3	17.9	0.0	37.2	41.8	0.0	75.1	85.4	0.0	73.4	71.4	43.1	108.8	256.2	41.7	178.1	233.6	43.1	67.6	41.5
1976	0.0	28.2	10.0	0.0	13.5	13.8	0.0	16.4	28.2	0.0	16.9	44.3	0.0	18.6	71.8	0.0	17.0	7.9	0.0	17.1	1.4
1977	0.0	11.1	4.0	0.0	6.0	6.5	0.0	7.5	9.2	0.0	13.7	35.9	0.0	18.3	43.1	0.0	16.2	25.4	0.0	16.9	1.6
1978	0.0	72.3	88.6	0.0	65.6	61.3	0.0	97.0	129.4	0.0	114.0	152.4	5.9	113.4	238.0	5.7	191.2	215.7	5.9	67.6	50.6
1979	0.0	49.1	47.6	0.0	49.2	47.3	21.3	81.6	94.3	0.0	86.5	120.8	19.5	118.6	261.8	18.8	92.2	94.3	19.5	39.5	12.2
1980	173.8	167.4	248.4	123.0	153.8	167.7	16.1	114.2	99.2	0.0	87.3	132.8	49.3	133.4	203.2	41.8	170.9	175.4	43.2	78.9	68.3
1981	0.0	42.0	18.6	0.0	34.8	27.0	0.0	34.7	47.0	0.0	41.6	111.0	0.0	32.0	126.4	0.0	32.3	32.1	0.0	34.5	0.4
1982	77.7	109.5	102.2	153.7	166.3	206.4	97.9	156.6	154.0	197.0	245.2	303.4	148.1	287.3	314.1	54.8	182.0	186.5	56.6	78.9	55.5
1983	69.2	119.3	102.1	112.5	150.9	144.3	197.3	243.3	267.9	91.7	140.3	142.9	232.8	210.7	320.3	163.7	372.4	379.9	94.7	209.2	206.4
1984	75.9	114.4	87.5	36.1	88.3	56.3	6.8	96.8	85.0	0.0	80.1	86.6	24.1	145.4	217.8	23.3	109.8	99.2	24.1	58.9	17.7
1985	0.0	24.6	15.8	0.0	35.4	28.0	0.0	51.2	41.6	0.0	62.2	129.6	0.0	32.9	142.0	0.0	30.6	34.2	0.0	31.3	4.3
1986	0.0	52.9	69.0	260.7	266.4	340.3	155.9	192.4	259.8	6.8	125.1	142.2	76.0	194.1	214.1	28.9	133.2	142.6	29.9	45.8	24.5
1987	0.0	25.7	7.9	0.0	17.9	21.2	0.0	25.3	41.7	0.0	22.4	85.1	0.0	17.8	79.8	0.0	22.2	11.6	0.0	33.2	2.2
1988	0.0	22.1	17.9	0.0	14.9	20.1	0.0	17.5	41.5	0.0	19.3	67.7	0.0	23.5	68.3	0.0	27.5	22.6	0.0	28.9	3.7
1989	0.0	13.9	11.0	0.0	15.1	24.9	0.0	61.0	144.9	0.0	81.5	151.8	0.0	106.7	130.3	0.0	70.7	63.3	0.0	35.4	6.4
1990	0.0	33.3	17.3	0.0	22.8	18.5	0.0	33.3	59.2	0.0	24.4	97.6	0.0	33.4	72.1	0.0	34.7	33.9	0.0	33.4	3.6

Table E-10: Unallocated, Regulated, and Natural Flow Comparison for January through July below Camanche (2040) (in TAF)\*

	January			February			March			April			May			June			July		
	Unallocated	Regulated	Natural	Unallocated	Regulated	Natural	Unallocated	Regulated	Natural	Unallocated	Regulated	Natural	Unallocated	Regulated	Natural	Unallocated	Regulated	Natural	Unallocated	Regulated	Natural
1991	0.0	4.9	3.6	0.0	8.2	4.0	0.0	22.9	51.5	0.0	26.4	66.8	0.0	30.9	133.6	0.0	44.2	79.7	0.0	34.1	8.8
1992	0.0	23.4	10.1	0.0	29.3	41.6	0.0	39.9	53.8	0.0	24.6	107.6	0.0	21.7	56.9	0.0	18.7	8.5	0.0	30.9	8.8
1993	0.0	76.0	105.2	0.0	73.8	69.3	0.0	120.7	155.3	0.0	104.0	149.5	24.8	177.1	272.9	24.0	177.8	190.2	24.8	53.7	43.2
1994	0.0	20.8	9.9	0.0	16.2	17.3	0.0	18.8	43.5	0.0	17.7	78.0	0.0	22.3	94.2	0.0	29.4	27.9	0.0	24.1	2.2
1995	0.0	109.9	144.9	18.7	73.4	73.1	165.7	204.0	253.4	136.5	164.4	188.9	237.3	250.6	332.3	83.5	302.8	317.2	72.5	182.9	194.8
1996	0.0	44.6	54.7	105.4	114.2	165.9	51.4	130.0	131.8	7.8	119.1	152.9	87.4	228.0	259.8	22.2	114.0	117.3	22.9	45.7	25.0
1997	357.8	348.8	442.7	73.7	112.6	87.1	11.3	94.8	85.0	0.0	95.2	124.3	6.8	148.2	174.9	6.6	81.9	69.8	6.8	39.8	11.2
1998	20.6	62.6	82.6	104.8	123.7	141.1	65.9	127.2	159.7	86.7	124.0	159.2	134.9	161.6	223.2	68.9	282.8	349.3	61.9	135.4	137.7
1999	17.3	69.2	61.2	89.2	119.9	130.9	27.5	90.7	83.3	0.0	87.2	112.5	35.4	123.8	244.8	40.1	155.1	166.0	33.4	59.9	28.3
2000	0.0	51.0	62.2	42.7	82.8	113.4	25.4	94.1	95.7	0.0	68.2	134.6	12.2	128.5	207.2	11.9	83.4	69.2	12.2	51.5	9.9
2001	0.0	19.8	12.8	0.0	18.2	20.9	0.0	38.2	63.9	0.0	54.0	89.7	0.0	44.7	140.3	0.0	32.5	12.3	0.0	34.5	4.1
2002	0.0	54.1	43.5	0.0	36.5	36.8	0.0	69.8	66.2	0.0	66.1	132.0	0.0	53.6	161.1	0.0	61.4	62.6	0.0	32.0	10.3
2003	0.0	57.2	38.2	0.0	49.7	33.2	0.0	48.2	57.0	0.0	59.8	96.6	2.9	105.9	216.4	2.8	123.8	132.3	2.9	36.1	16.2
2004	0.0	51.8	22.8	0.0	50.1	49.0	9.0	78.7	111.1	0.0	47.3	121.6	0.0	28.5	116.1	0.0	47.8	30.1	0.0	32.7	4.5
2005	0.0	83.9	72.3	11.9	78.3	65.1	66.1	123.8	118.6	27.9	122.1	125.6	90.8	181.1	320.3	48.6	169.7	198.7	34.4	73.5	49.8
2006	88.6	109.9	141.8	48.5	79.9	95.9	64.3	159.7	131.5	229.4	292.0	312.7	142.0	293.6	356.4	60.0	191.0	191.7	26.9	70.6	33.2
2007	0.0	32.8	18.2	0.0	35.7	53.7	0.0	46.7	74.5	0.0	29.0	98.7	0.0	35.6	95.8	0.0	28.4	17.3	0.0	32.2	6.8
2008	0.0	29.8	22.2	0.0	30.9	27.9	0.0	46.5	50.6	0.0	28.9	82.8	0.0	40.5	143.0	0.0	35.5	51.2	0.0	24.3	5.6
2009	0.0	42.0	31.8	0.0	38.5	45.3	0.0	79.8	103.0	0.0	69.8	113.5	0.0	159.9	243.1	0.0	57.7	54.1	0.0	39.9	9.8
2010	0.0	45.7	26.7	0.0	42.6	31.0	0.0	59.3	58.7	0.0	81.6	103.8	22.7	117.0	170.5	22.0	133.0	235.6	22.7	48.7	30.4

\* Unallocated water is simulated below Camanche and regulated and unimpaired flow is simulated at Mokelumne Hill.

Table E-11: Unallocated, Regulated, and Natural Flow Comparison for August through December below Camanche (2040) (in TAF)\*

	August			September			October			November			December			Total		
	Unallocated	Regulated	Natural	Unallocated	Regulated	Natural	Unallocated	Regulated	Natural	Unallocated	Regulated	Natural	Unallocated	Regulated	Natural	Unallocated	Regulated	Natural
1953	16.5	37.5	4.0	16.0	38.0	2.2	0.0	42.1	5.7	0.0	39.3	11.4	0.0	38.0	14.7	105.0	660.0	671.5
1954	0.0	34.9	0.0	0.0	36.8	2.3	0.0	38.1	4.1	0.0	41.0	7.9	0.0	34.7	28.6	0.0	555.4	572.9
1955	0.0	34.4	2.8	0.0	32.6	0.9	0.0	33.7	2.4	0.0	33.8	5.8	108.1	163.3	259.8	108.1	557.5	719.6
1956	37.1	37.0	6.5	35.9	34.4	4.4	0.0	40.1	9.1	0.0	43.0	10.7	0.0	45.2	13.2	503.0	1,111.5	1,049.0
1957	4.0	31.5	2.4	3.9	32.4	2.3	0.0	39.8	4.0	0.0	43.6	7.2	0.0	43.6	16.1	19.7	616.3	615.6
1958	42.5	44.9	8.7	41.1	35.9	3.7	0.0	40.0	3.9	0.0	38.3	5.5	0.0	33.8	5.0	502.9	1,036.7	1,069.3
1959	0.0	32.7	0.1	0.0	30.9	4.6	0.0	32.6	2.2	0.0	30.6	1.9	0.0	32.2	3.3	0.0	398.7	369.4
1960	0.0	31.8	0.0	0.0	30.8	1.0	0.0	31.1	0.5	0.0	30.1	6.6	0.0	31.9	10.8	0.0	416.2	428.3
1961	0.0	30.1	0.0	0.0	30.1	0.3	0.0	31.0	0.4	0.0	19.1	3.8	0.0	18.8	10.4	0.0	287.5	285.4
1962	0.0	37.3	2.4	0.0	34.3	0.0	0.0	40.3	20.0	0.0	37.8	6.8	0.0	37.9	18.5	0.0	641.5	676.6
1963	31.6	38.9	2.8	30.5	36.6	3.4	0.0	38.2	7.0	21.5	41.7	46.4	0.0	43.7	23.9	329.0	876.8	912.8
1964	0.0	35.3	2.0	0.0	34.6	2.5	0.0	36.7	4.4	0.0	42.9	15.6	193.3	202.7	315.5	193.3	605.5	728.7
1965	45.0	45.4	20.9	43.6	56.1	7.0	0.0	56.1	5.3	17.7	57.0	26.5	1.3	46.5	21.9	411.3	1,051.1	955.1
1966	0.0	33.6	1.0	0.0	36.2	1.9	0.0	33.4	1.5	0.0	40.3	17.6	0.0	71.8	72.3	1.3	481.0	523.0
1967	56.3	40.5	14.0	54.5	38.5	5.3	0.0	39.6	5.4	0.0	39.9	7.1	0.0	40.2	11.0	502.6	1,072.9	1,125.3
1968	0.0	31.6	2.5	0.0	32.4	1.0	0.0	32.8	4.6	0.0	40.1	34.5	0.0	44.6	23.9	0.0	449.4	465.0
1969	46.2	50.0	7.0	44.7	46.7	3.7	0.0	48.5	11.1	0.0	39.7	11.8	6.9	54.8	65.7	758.2	1,327.3	1,384.7
1970	9.4	35.5	3.9	9.1	34.2	0.3	0.0	36.6	2.9	20.2	52.5	31.1	31.3	74.5	53.8	348.8	929.7	900.1
1971	20.3	54.5	3.4	19.6	41.5	0.5	0.0	44.4	3.2	3.4	33.3	12.1	5.9	41.5	29.8	167.2	748.2	720.0
1972	0.0	34.2	0.9	0.0	33.9	0.9	0.0	37.5	4.4	0.0	39.7	11.3	0.0	46.1	38.6	0.0	514.0	525.3
1973	23.2	34.7	1.5	22.5	34.8	0.0	0.0	38.8	6.3	62.9	54.9	85.6	37.7	76.0	73.8	319.9	839.7	915.3
1974	38.4	56.4	5.8	37.2	44.6	0.9	0.0	35.8	3.1	0.0	30.7	5.2	0.0	33.0	11.3	323.8	931.4	875.9
1975	43.1	55.7	7.4	41.7	52.9	2.9	0.0	45.8	21.9	3.1	41.6	22.9	0.0	39.0	12.0	215.7	803.5	814.9
1976	0.0	17.8	4.3	0.0	17.2	2.2	0.0	12.3	2.0	0.0	12.2	2.5	0.0	9.1	1.9	0.0	196.3	190.2
1977	0.0	16.4	1.4	0.0	17.5	1.4	0.0	1.1	0.8	0.0	2.9	3.4	0.0	23.7	29.5	0.0	151.4	162.2
1978	5.9	53.0	3.7	5.7	40.7	13.6	0.0	36.8	2.2	0.0	34.4	5.2	0.0	31.6	8.8	29.2	917.7	969.4
1979	19.5	36.1	3.1	18.8	32.0	0.2	0.0	34.8	9.0	0.0	38.9	18.1	0.0	48.4	19.9	117.4	707.0	728.5
1980	43.2	36.8	7.4	41.8	34.6	2.9	0.0	35.3	2.5	0.0	33.3	3.0	0.0	37.9	8.1	532.2	1,083.8	1,118.9
1981	0.0	28.6	0.5	0.0	30.1	0.5	0.0	35.0	5.6	0.0	45.0	78.2	72.3	83.4	132.6	72.3	474.1	579.8
1982	56.6	55.4	7.9	54.8	43.1	13.7	0.0	47.5	67.8	64.9	83.5	61.8	89.3	122.0	109.1	1,051.2	1,577.2	1,582.5
1983	94.7	70.0	31.0	91.6	57.6	16.8	0.0	56.1	10.4	120.8	116.2	160.1	149.9	179.5	188.4	1,418.9	1,925.7	1,970.6
1984	24.1	50.2	3.6	23.3	35.4	1.3	0.0	39.0	4.7	15.1	46.3	31.1	0.0	43.2	16.6	252.9	907.7	707.2
1985	0.0	34.5	1.5	0.0	34.1	2.7	0.0	37.1	1.9	0.0	39.6	11.8	0.0	39.8	25.2	0.0	453.3	438.6
1986	29.9	38.7	6.7	28.9	37.2	2.0	0.0	37.9	1.6	0.0	37.8	1.6	0.0	33.3	3.5	616.9	1,194.8	1,208.0
1987	0.0	32.3	0.7	0.0	28.6	0.7	0.0	15.1	1.8	0.0	13.8	2.0	0.0	18.2	3.5	0.0	272.6	258.2
1988	0.0	24.2	0.8	0.0	21.1	0.7	0.0	14.3	0.2	0.0	13.3	9.5	0.0	13.7	9.4	0.0	240.5	262.4
1989	0.0	32.2	1.8	0.0	33.8	3.7	0.0	24.1	10.2	0.0	36.9	12.8	0.0	35.6	10.3	0.0	546.9	571.2
1990	0.0	29.7	1.0	0.0	28.9	0.4	0.0	32.4	0.4	0.0	9.3	0.9	0.0	12.3	3.1	0.0	327.9	308.2



Table E-11: Unallocated, Regulated, and Natural Flow Comparison for August through December below Camanche (2040) (in TAF)\*

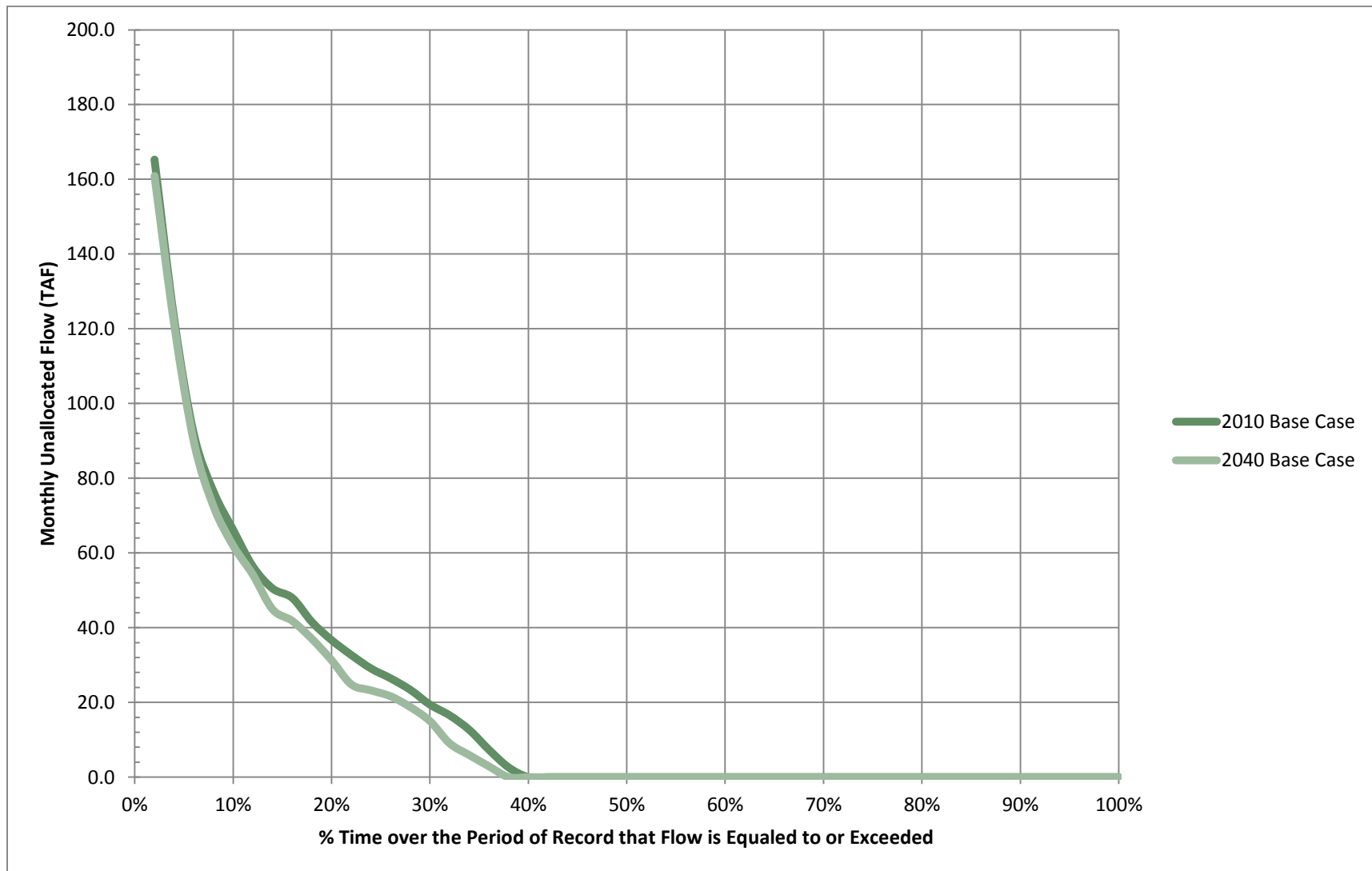
	August			September			October			November			December			Total		
	Unallocated	Regulated	Natural	Unallocated	Regulated	Natural	Unallocated	Regulated	Natural	Unallocated	Regulated	Natural	Unallocated	Regulated	Natural	Unallocated	Regulated	Natural
1991	0.0	29.9	2.0	0.0	29.8	0.0	0.0	33.3	5.7	0.0	34.1	8.6	0.0	31.4	8.7	0.0	330.0	373.1
1992	0.0	30.2	1.2	0.0	20.3	2.2	0.0	20.0	2.2	0.0	15.4	5.4	0.0	24.6	18.7	0.0	299.0	316.9
1993	24.8	54.2	9.8	24.0	35.4	4.0	0.0	40.6	4.3	0.0	32.1	2.6	0.0	32.4	4.1	122.3	977.8	1,010.3
1994	0.0	26.5	1.3	0.0	33.3	1.1	0.0	33.4	2.9	0.0	14.5	15.2	0.0	32.9	20.5	0.0	290.1	314.0
1995	72.5	51.0	30.4	70.1	47.3	7.5	0.0	50.7	4.7	0.0	34.0	4.4	0.0	36.6	31.3	856.7	1,507.7	1,582.9
1996	22.9	44.7	6.1	22.2	34.8	2.4	0.0	33.3	0.0	16.6	53.3	40.4	127.9	141.5	161.8	486.6	1,103.3	1,118.0
1997	6.8	41.5	4.6	6.6	37.0	3.3	0.0	39.8	2.2	8.7	41.9	8.9	0.0	28.1	11.6	485.2	1,109.7	1,025.6
1998	61.9	58.8	15.9	59.9	50.1	8.1	0.0	42.8	7.5	0.0	41.9	17.7	0.0	49.4	25.4	665.7	1,260.3	1,327.4
1999	33.4	41.6	7.6	32.4	37.8	3.5	0.0	35.5	1.6	0.0	39.8	9.9	0.0	34.6	8.3	308.8	895.2	858.0
2000	12.2	43.5	1.6	11.9	33.3	4.2	0.0	34.7	5.2	0.0	36.4	6.3	0.0	34.8	5.6	128.5	742.3	715.1
2001	0.0	32.1	2.3	0.0	28.1	3.6	0.0	25.7	0.0	0.0	20.3	14.0	0.0	37.2	32.7	0.0	385.1	396.5
2002	0.0	31.5	1.7	0.0	30.0	0.0	0.0	32.0	1.2	0.0	34.2	20.0	0.0	40.8	22.7	0.0	542.0	558.1
2003	2.9	33.1	1.0	2.8	35.1	0.9	0.0	35.8	0.8	0.0	32.1	4.0	0.0	47.2	30.5	14.2	664.0	627.0
2004	0.0	34.2	0.3	0.0	31.0	0.0	0.0	17.6	9.7	0.0	33.0	11.8	0.0	45.3	24.6	9.0	498.1	501.5
2005	34.4	49.3	5.4	33.3	41.0	1.7	0.0	32.7	6.3	0.0	37.4	8.5	88.7	104.9	128.5	436.1	1,097.8	1,100.8
2006	26.9	53.4	7.1	26.0	31.9	4.6	0.0	34.4	6.3	1.2	37.1	14.4	2.0	45.7	20.1	715.7	1,399.2	1,315.6
2007	0.0	31.2	1.4	0.0	29.9	2.6	0.0	21.2	0.6	0.0	32.8	3.0	0.0	25.3	6.9	0.0	380.7	379.6
2008	0.0	28.8	2.6	0.0	20.7	3.2	0.0	31.0	0.2	0.0	32.3	13.6	0.0	28.8	7.7	0.0	377.9	410.6
2009	0.0	34.9	3.3	0.0	25.5	1.6	0.0	26.7	4.0	0.0	28.4	3.0	0.0	34.5	10.8	0.0	637.5	623.2
2010	22.7	28.7	2.2	22.0	20.9	1.4	0.0	42.2	31.8	23.6	40.2	25.2	72.9	120.0	123.4	208.7	779.9	840.7

\* Unallocated water is simulated below Camanche and regulated and unimpaired flow is simulated at Mokelumne Hill.

Flow duration curves for each location under 2010 and 2040 baseline diversion assumptions are presented in Figure E-1, Figure E-2, Figure E-3, and Figure E-4. Note that the unallocated flow curve is presented for below Camanche and total flow curves are presented for the remaining three nodes. Flow duration curves indicate the percentage of time over the period of record that flow in the river is expected to be equal to or exceed a certain amount of water, based on historical hydrologic conditions and projected diversion levels.

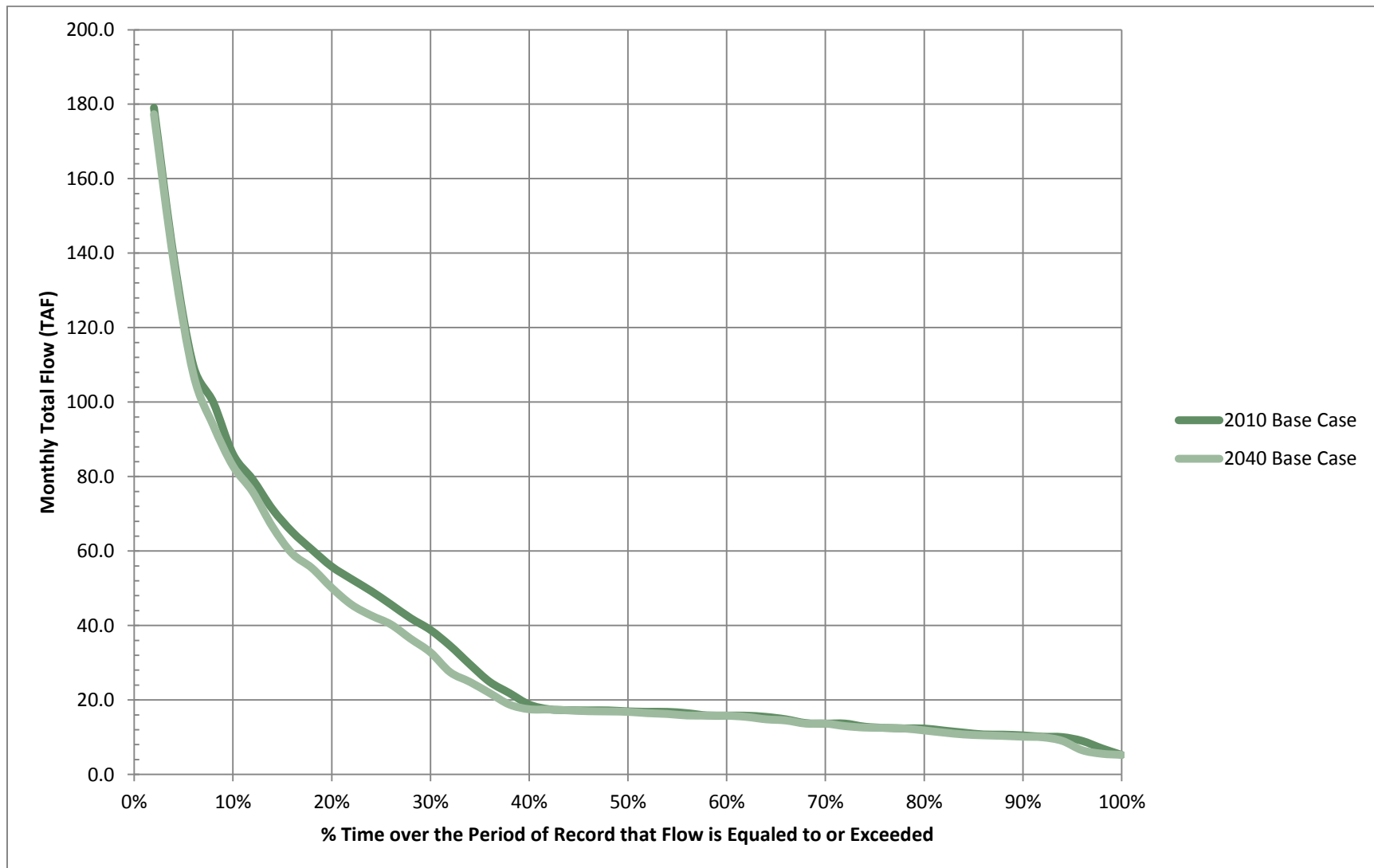
Appendix J includes a monthly breakdown over the period of record of the amount of unallocated water in the Mokelumne River below Camanche Reservoir for both the 2010 and the 2040 base cases.

Figure E-1: Flow Duration Curve for Monthly Unallocated Flow below Camanche Reservoir\*



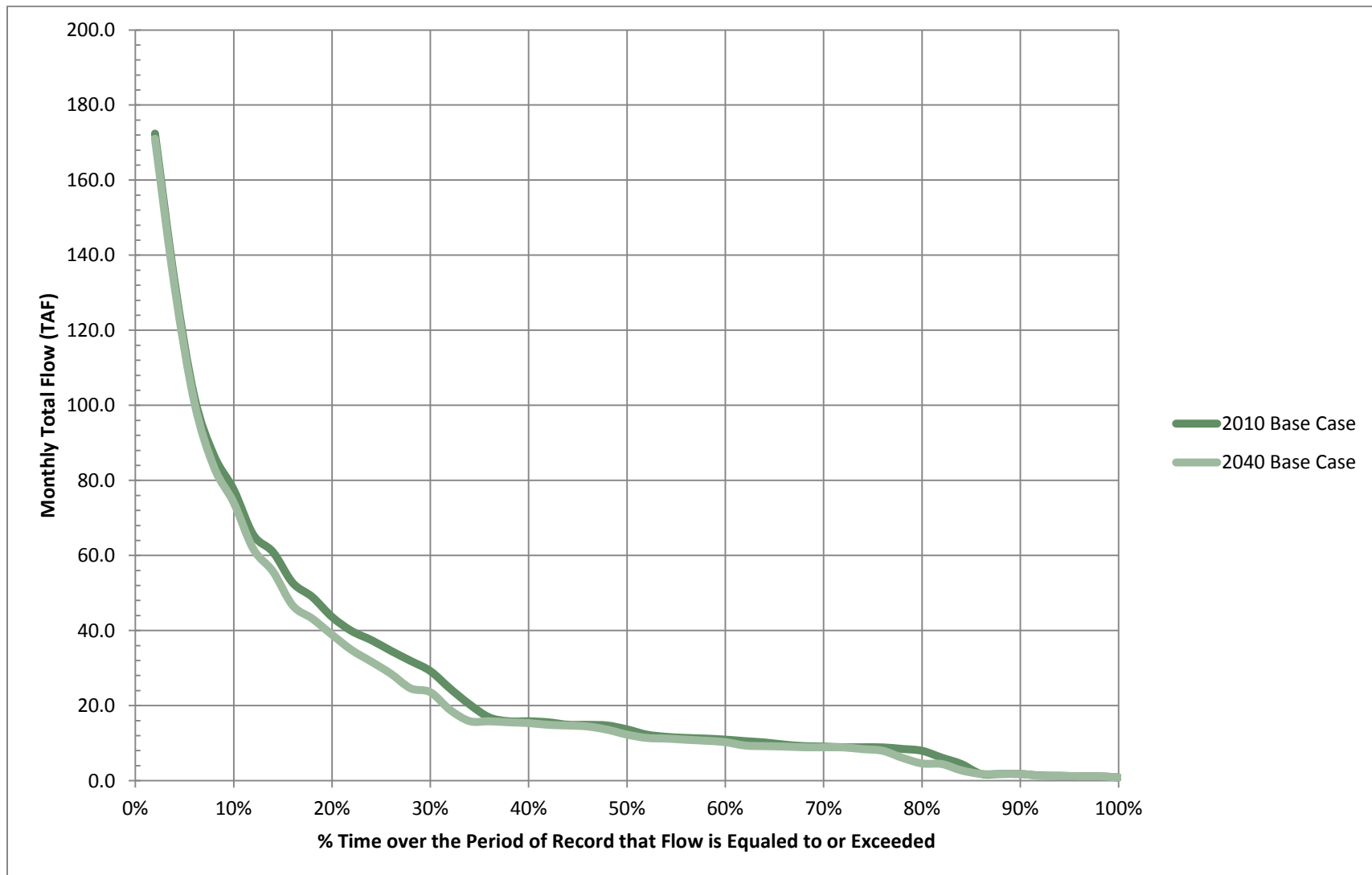
\* Flow duration curves indicate the percentage of time that flow in the River is expected to be equal to or exceed a certain amount of water.

Figure E-2: Flow Duration Curve for Monthly Total Flow below Highway 99\*



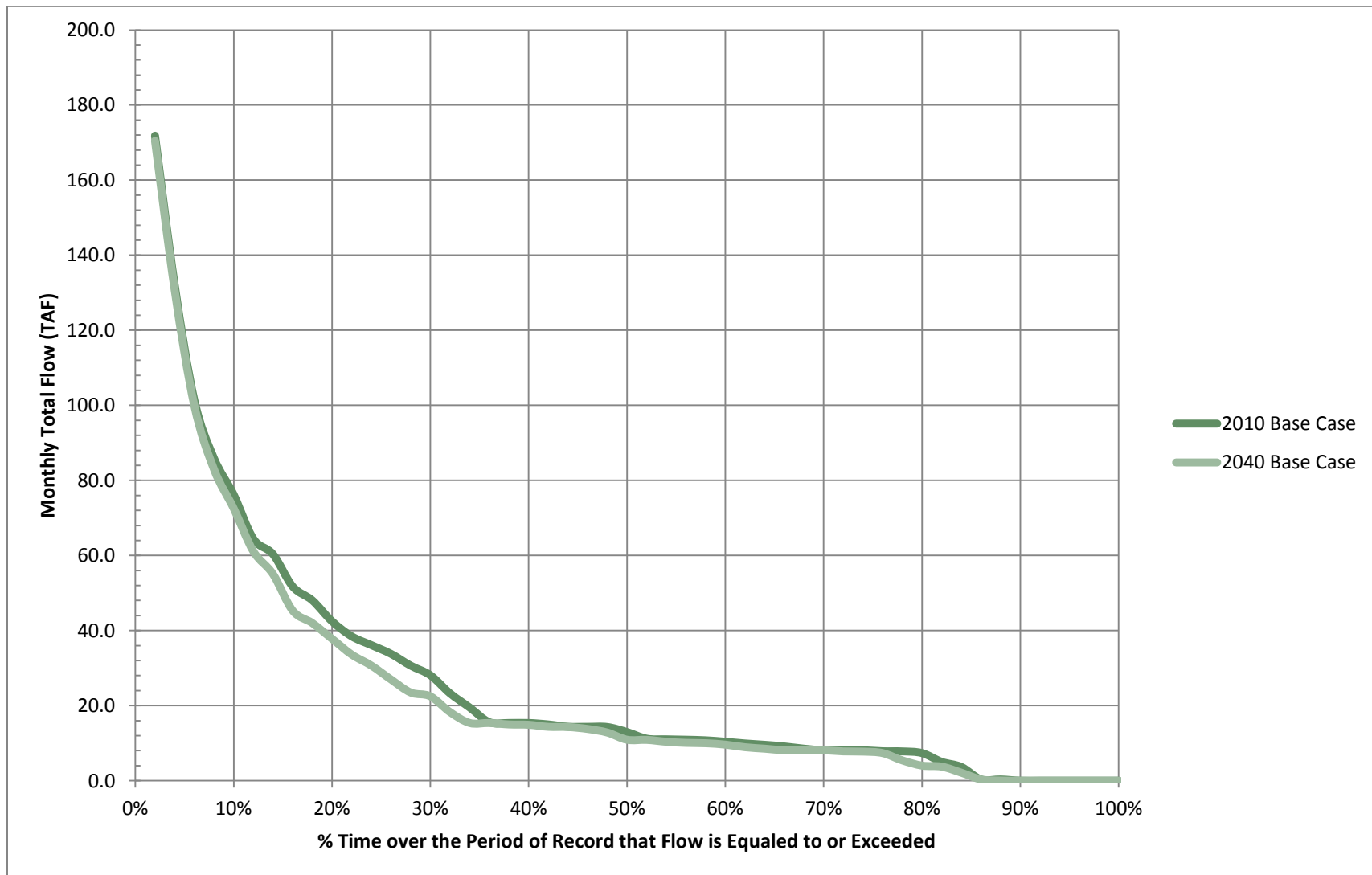
\* Flow duration curves indicate the percentage of time that flow in the River is expected to be equal to or exceed a certain amount of water.

Figure E-3: Flow Duration Curve for Monthly Total Flow below Woodbridge Diversion Dam\*



\* Flow duration curves indicate the percentage of time that flow in the River is expected to be equal to or exceed a certain amount of water.

Figure E-4: Flow Duration Curve for Monthly Total Flow below Interstate 5\*



\* Flow duration curves indicate the percentage of time that flow in the River is expected to be equal to or exceed a certain amount of water.

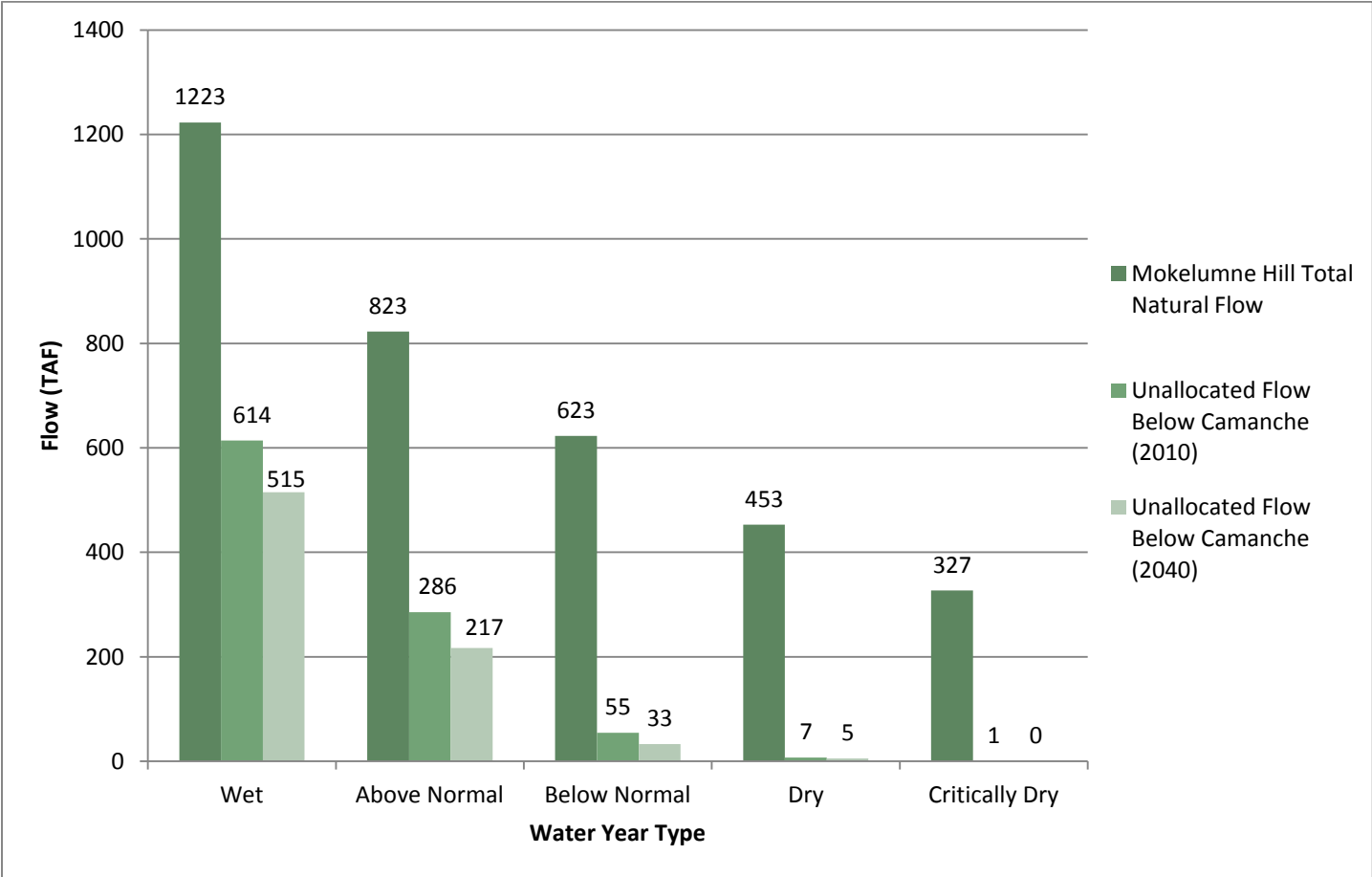
## **Appendix F: Hydrologic Year Type Average Unallocated Flow**

Appendix F compares water year type and the averages for total natural flow at Mokelumne Hill and unallocated flow below Camanche in 2010 and 2040 by water year type. Results indicate that total natural flow is greater than unallocated flow at Mokelumne Hill and that unallocated flow in 2010 is greater than unallocated flow in 2040 due to increased diversions in 2040. This pattern holds for each of the five hydrologic year types.

**Hydrologic Year Type Average Unallocated Flow**

Water year types from the San Joaquin Valley Index were used to determine average unallocated water and average total natural flow in a given year type. As described previously, the Index is based on measured unimpaired runoff and includes five water year types, including wet, above normal, below normal, dry, and critically dry (DWR 2013). For each of these water year types, the averages for total natural flow at Mokelumne Hill and unallocated flow below Camanche in 2010 and 2040 were calculated. Results are shown in Figure F-1 and indicate that total natural flow is greater than unallocated flow at Mokelumne Hill and that unallocated flow in 2010 is greater than unallocated flow in 2040. This pattern holds for each of the five hydrologic year types.

**Figure F-1: Average Total Natural Flow at Mokelumne Hill Compared to Unallocated Flow below Camanche in 2010 and 2040 Baseline Conditions by Water Year Type (in TAF)**





## **Appendix G: MOCASIM Modeled Releases and Joint Settlement Agreements Flows**

Appendix G compares annual JSA required flows and annual modeled flows. Results indicate that the amount of water being released decreases from 2010 to 2040, but that in each case, more water is being released than is required by the JSA.

### ***Modeled Releases and Joint Settlement Agreement Flows***

The JSA specifies in-river flows that help maintain fishery, wildlife, and habitat resources along the Mokelumne River. These flows are specified below Camanche Dam and below Woodbridge Diversion Dam and are based on time of year and hydrologic year type. As noted in the 2008 Lower Mokelumne River Project Joint Settlement Agreement Ten-Year Review Report, actual flows at these two points have always exceeded the required JSA flows (EBMUD 2008).

Figures G-1 through G-4 show the annual JSA required flows and the annual modeled flows. The bars indicate the modeled flows and the line indicates the JSA required flows. Figure G-1 and Figure G-2 are for the compliance point below Camanche Dam for 2010 and 2040, respectively. Figure G-3 and Figure G-4 are for the compliance point below Woodbridge Diversion Dam for 2010 and 2040, respectively. Results indicate that the amount of water being released decreases from 2010 to 2040, but that in each case, more water is being released than is required by the JSA.<sup>1</sup>

---

<sup>1</sup> The Joint Settlement Agreement is not static and is subject to change. Any increase in required flows would likely decrease the amount of unallocated water.

Figure G-1: Required and Modeled Annual Flows for the 2010 Base Case from Camanche Reservoir

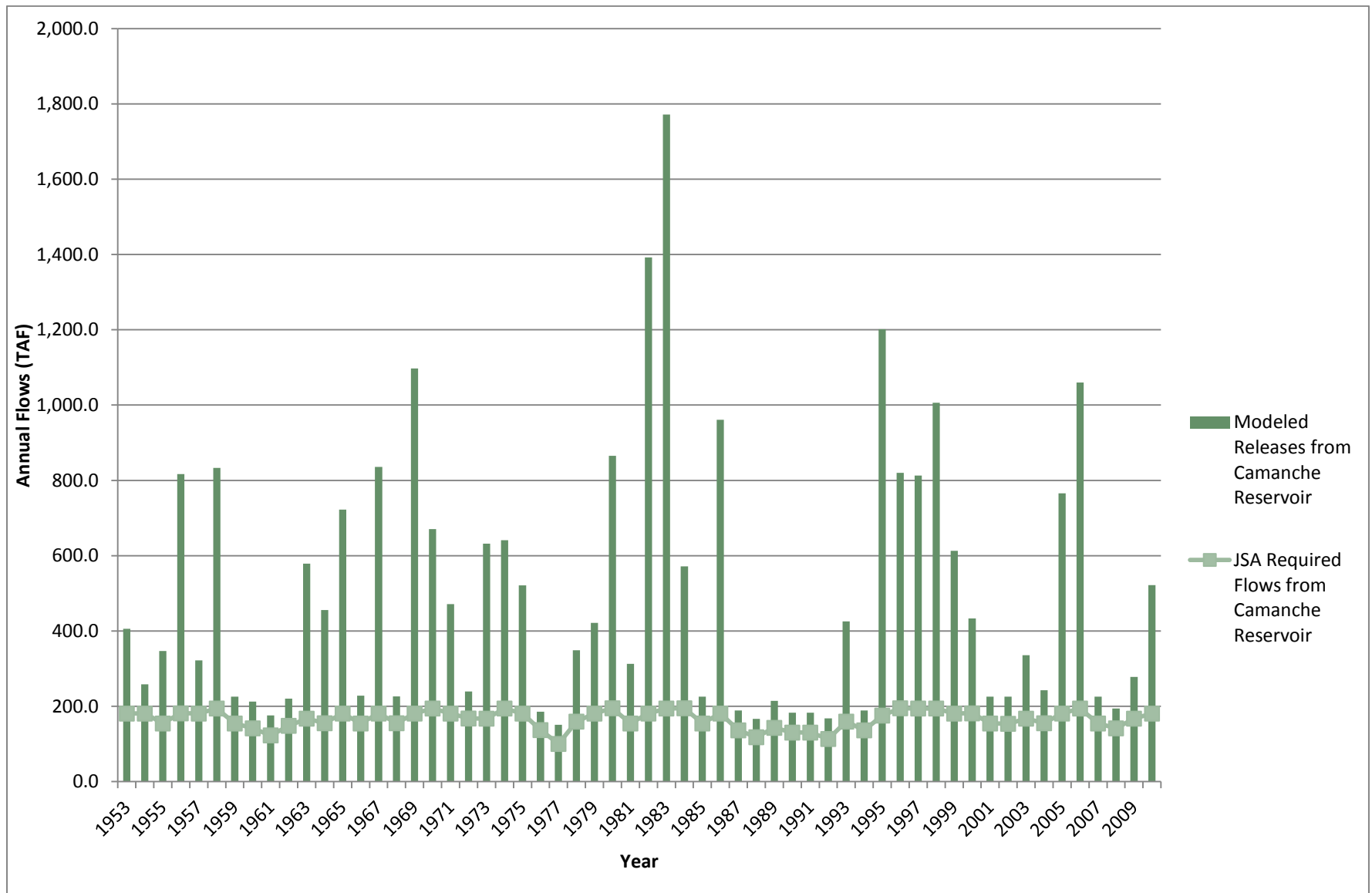


Figure G-2: Required and Modeled Annual Flows for the 2040 Base Case from Camanche Reservoir

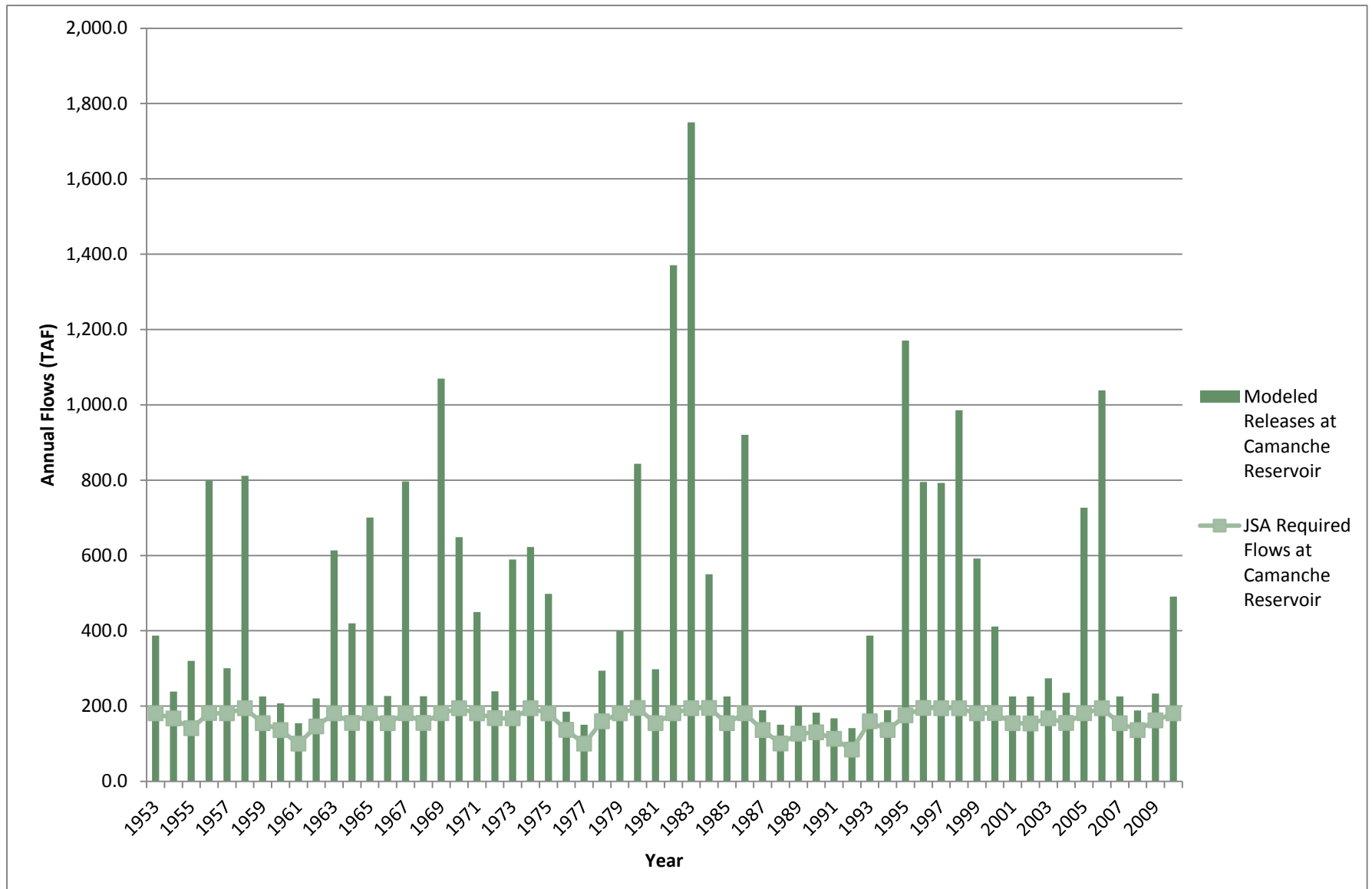


Figure G-3: Required and Modeled Annual Flows for the 2010 Base Case from Woodbridge Diversion Dam

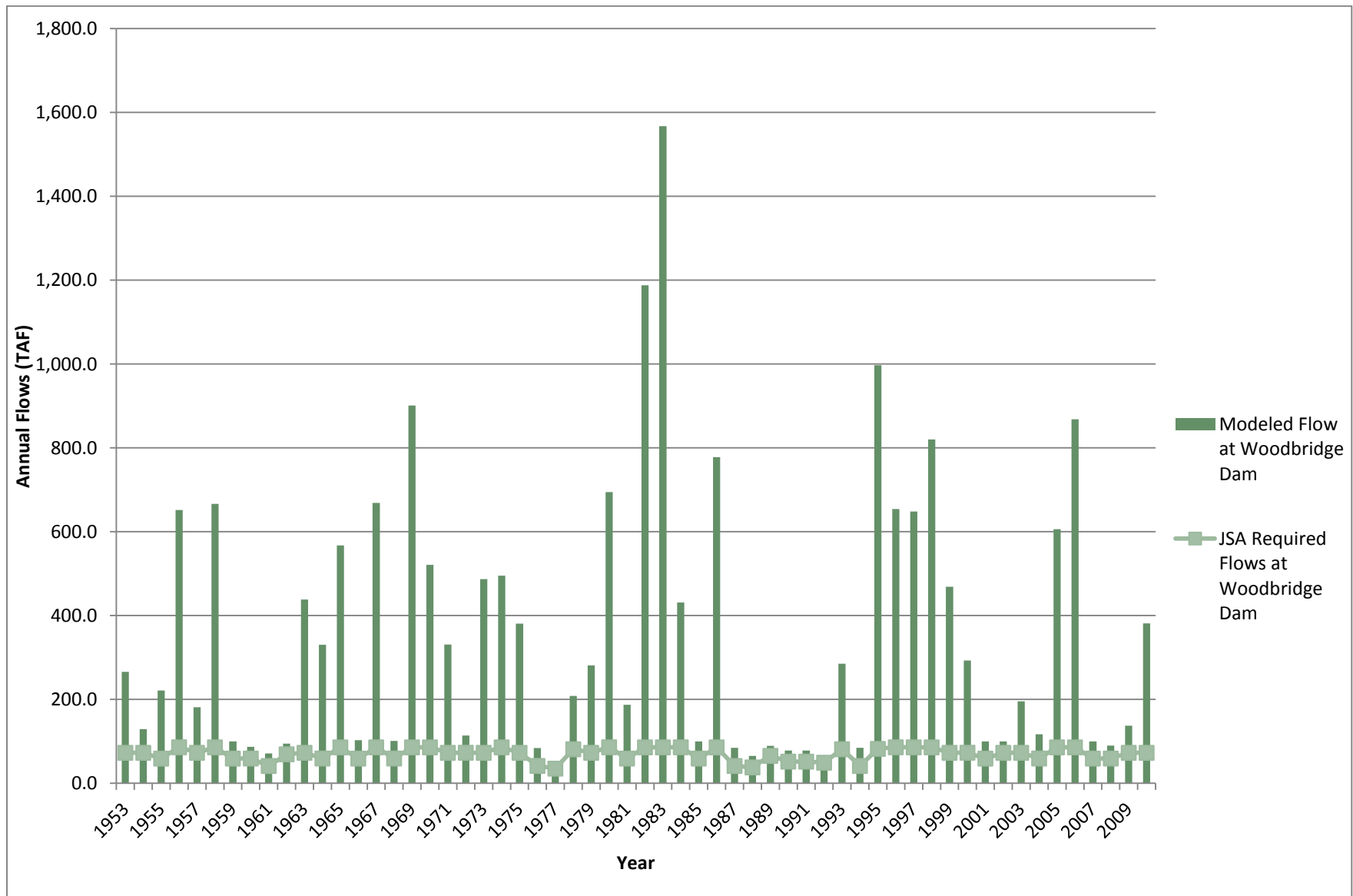
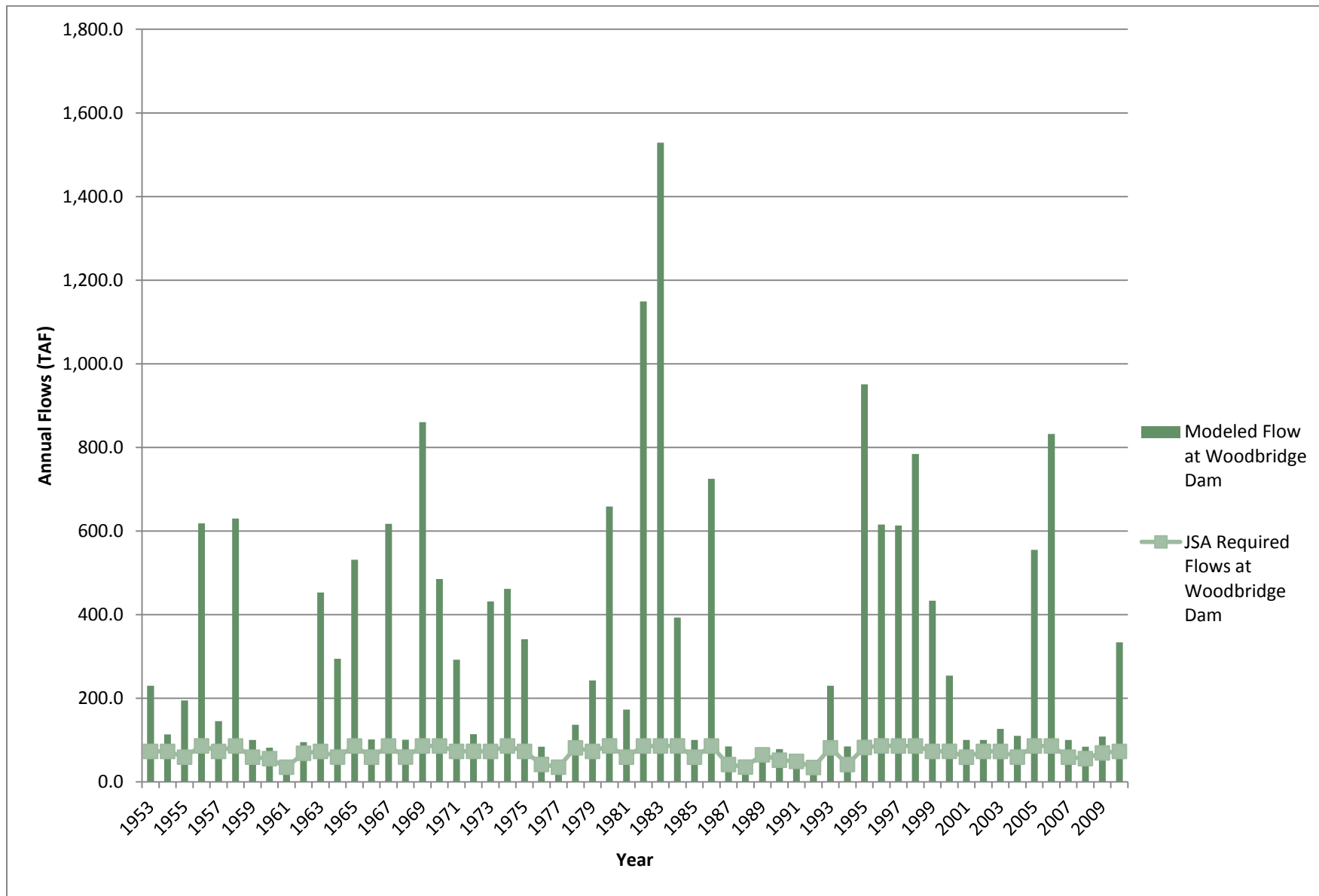


Figure G-4: Required and Modeled Annual Flows for the 2040 Base Case from Woodbridge Diversion Dam



## **Appendix H: Calculated Daily Unallocated Flows**

Appendix H presents a constructed daily flow regime downstream of Camanche Dam by year for all years between 1998 and 2010. For the three wet years during that period (1998, 2005, and 2006), daily allocated and unallocated flows are presented on a monthly basis. This information is shown to provide information regarding historical daily flow variability. It is not intended to establish estimated pulse flows or geomorphic and/or fishery impacts.

### ***Calculated Daily Unallocated Flows***

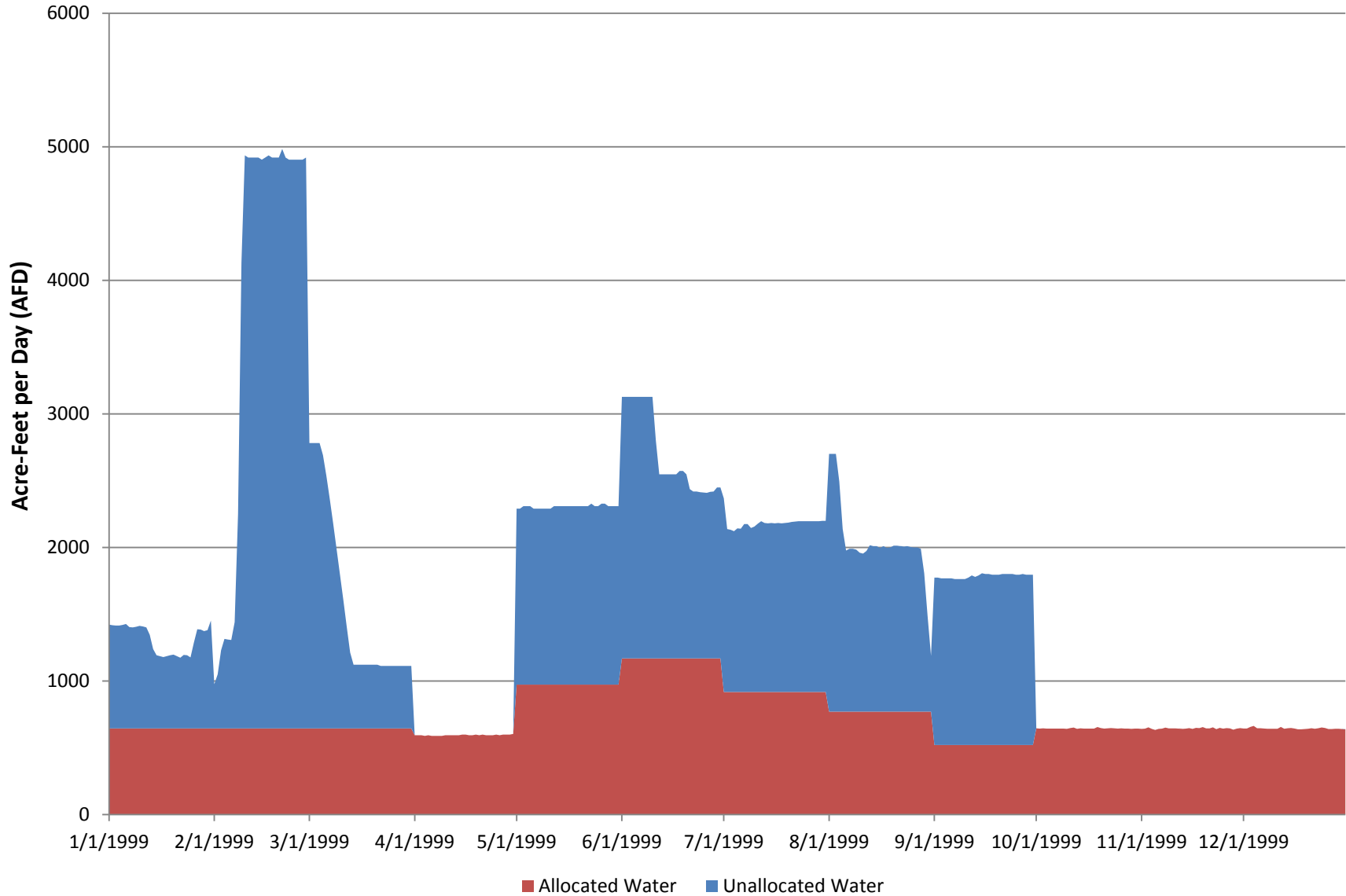
A daily flow regime was constructed to provide indication of the historical daily variability of flows downstream of Camanche Dam. Historical daily flow data for Camanche Reservoir was downloaded (from USGS gage 11323500 for the years 1988 through 2010). This data was used to define the historical daily flow distribution downstream of Camanche Dam for the simulated period of record. This daily distribution was applied to the modeled monthly flows at the below Camanche node to construct a simulated daily flow pattern below Camanche reflecting historical Camanche Reservoir operating conditions. Daily flows were only calculated from 1998 to 2010 because historical flow patterns prior to 1998 are not reflective of current river conditions.

It was assumed that the difference between simulated total monthly flows and simulated monthly unallocated flows reflected simulated monthly “allocated flows.” Daily allocated flows were calculated assuming that daily allocations or withdrawals would remain relatively constant throughout the month when sufficient flow was available to meet the average requirement. Because sufficient flow was not available in all days to meet an “average” daily allocated flow, the allocated flow in days with sufficient flow available was slightly increased to reflect the reductions required during lower flow days. Daily unallocated flow was calculated as the difference between daily total flow and daily allocated flow.

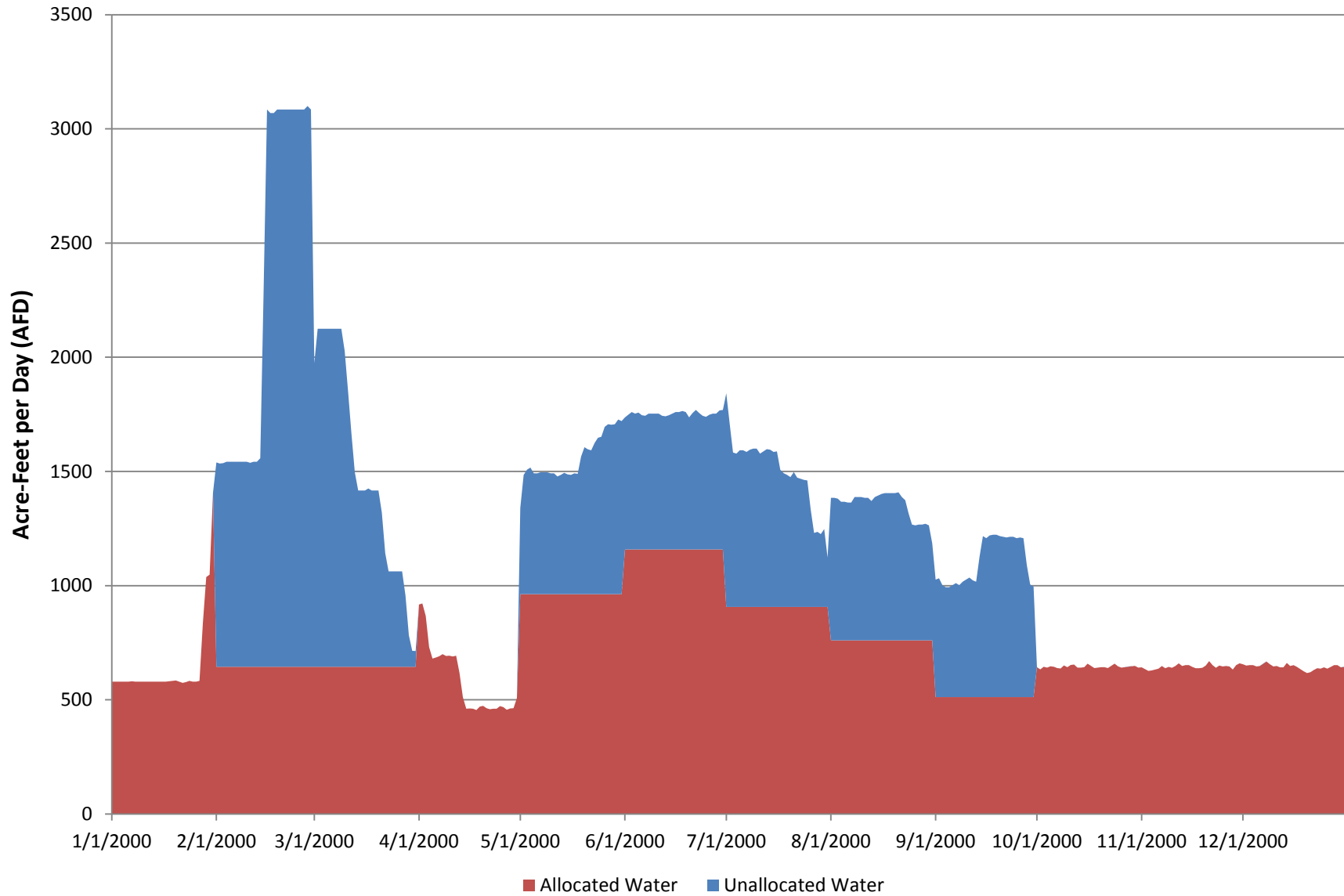
Estimated daily flows are presented by year for all years between 1998 and 2010. For the three wet years during that period (1998, 2005, and 2006), daily allocated and unallocated flows are presented on a monthly basis. These figures are provided for both the 2010 and 2040 baseline cases. This information is shown to provide information regarding historical daily flow variability. It is not intended to establish estimated pulse flows or geomorphic and/or fishery impacts.



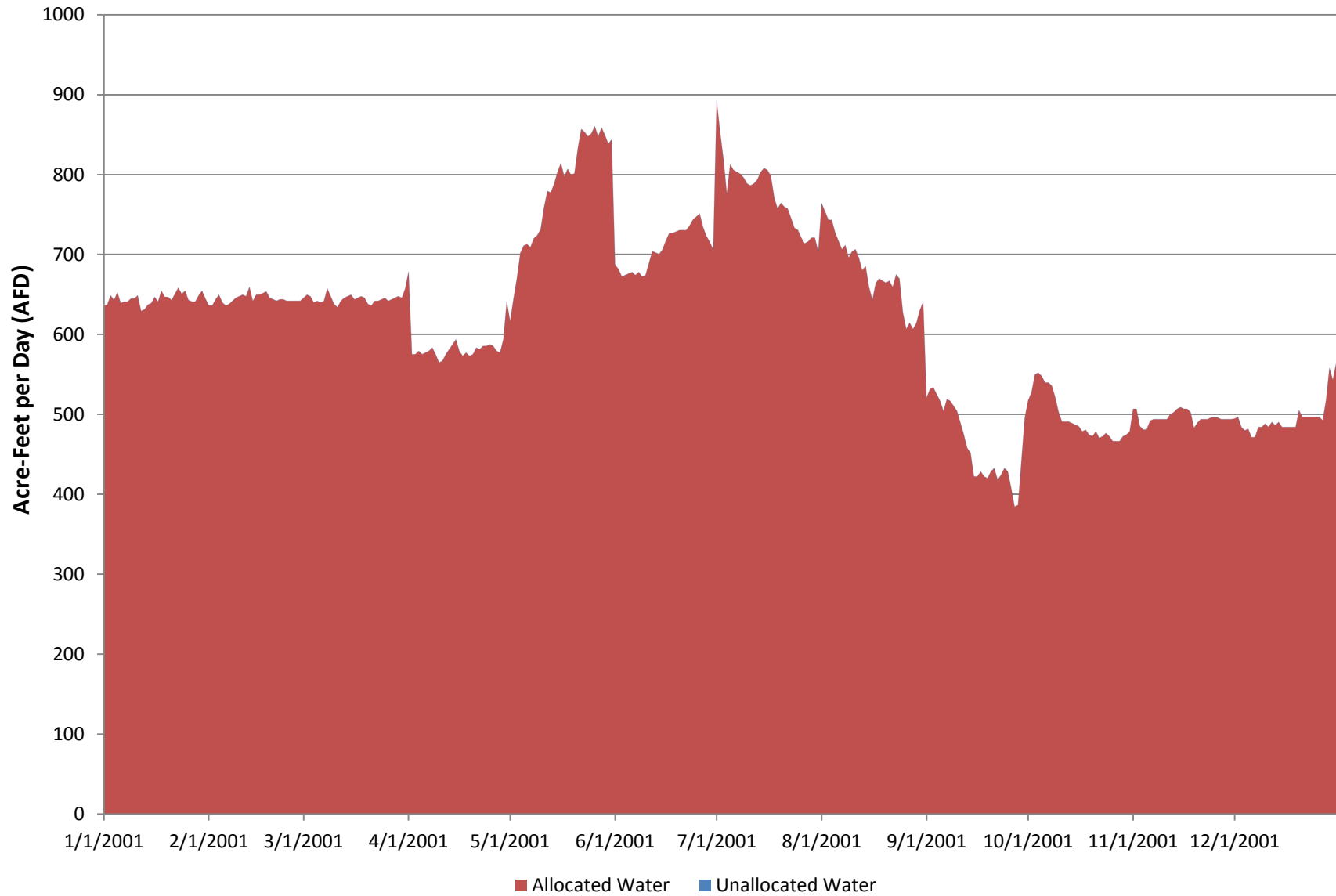
**Figure H-1: Daily Unallocated Water Calculation Downstream of Camanche Reservoir - 1999 hydrology (2010 diversion assumptions)**



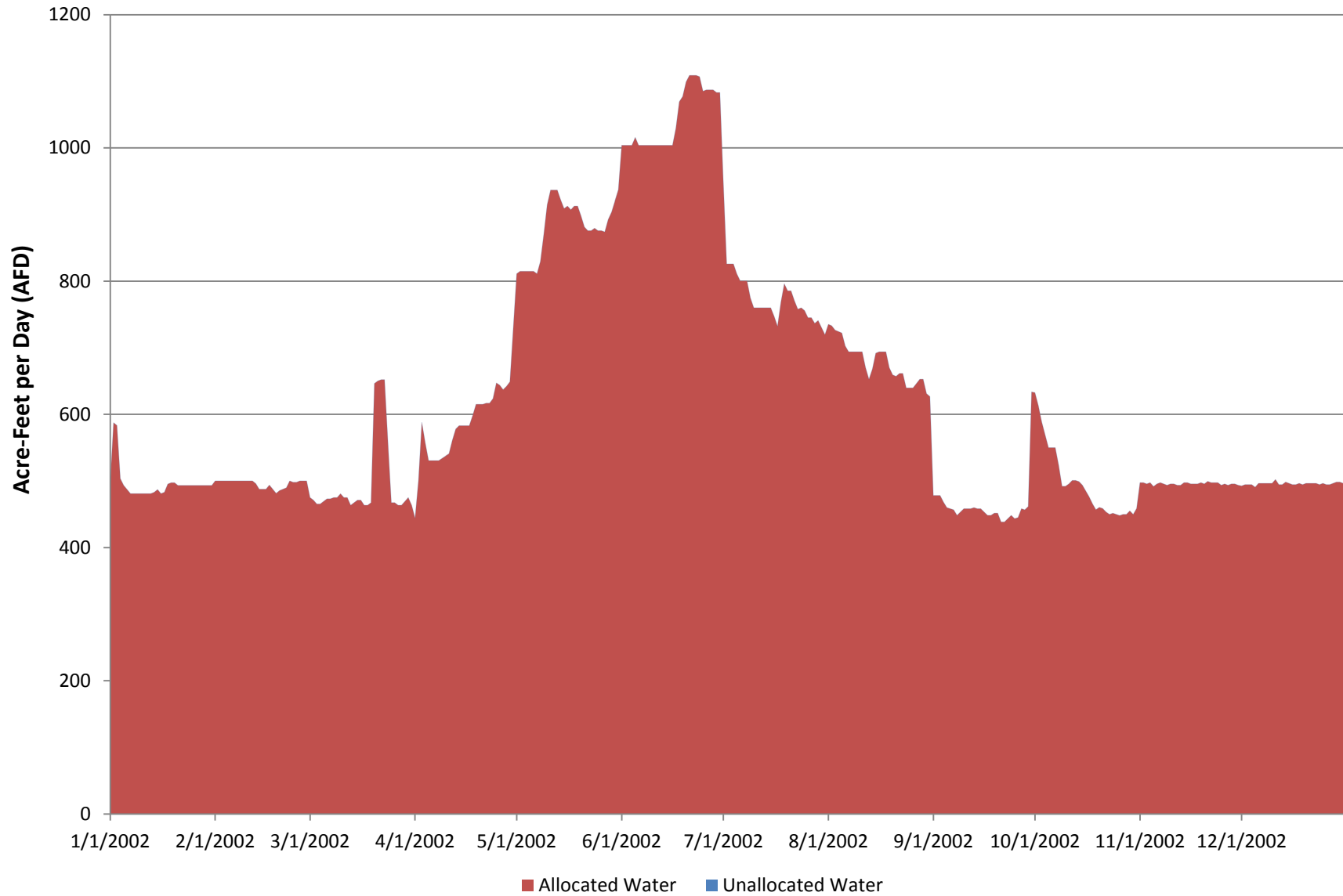
**Figure H-2: Daily Unallocated Water Calculation Downstream of Camanche Reservoir - 2000 hydrology (2010 diversion assumptions)**



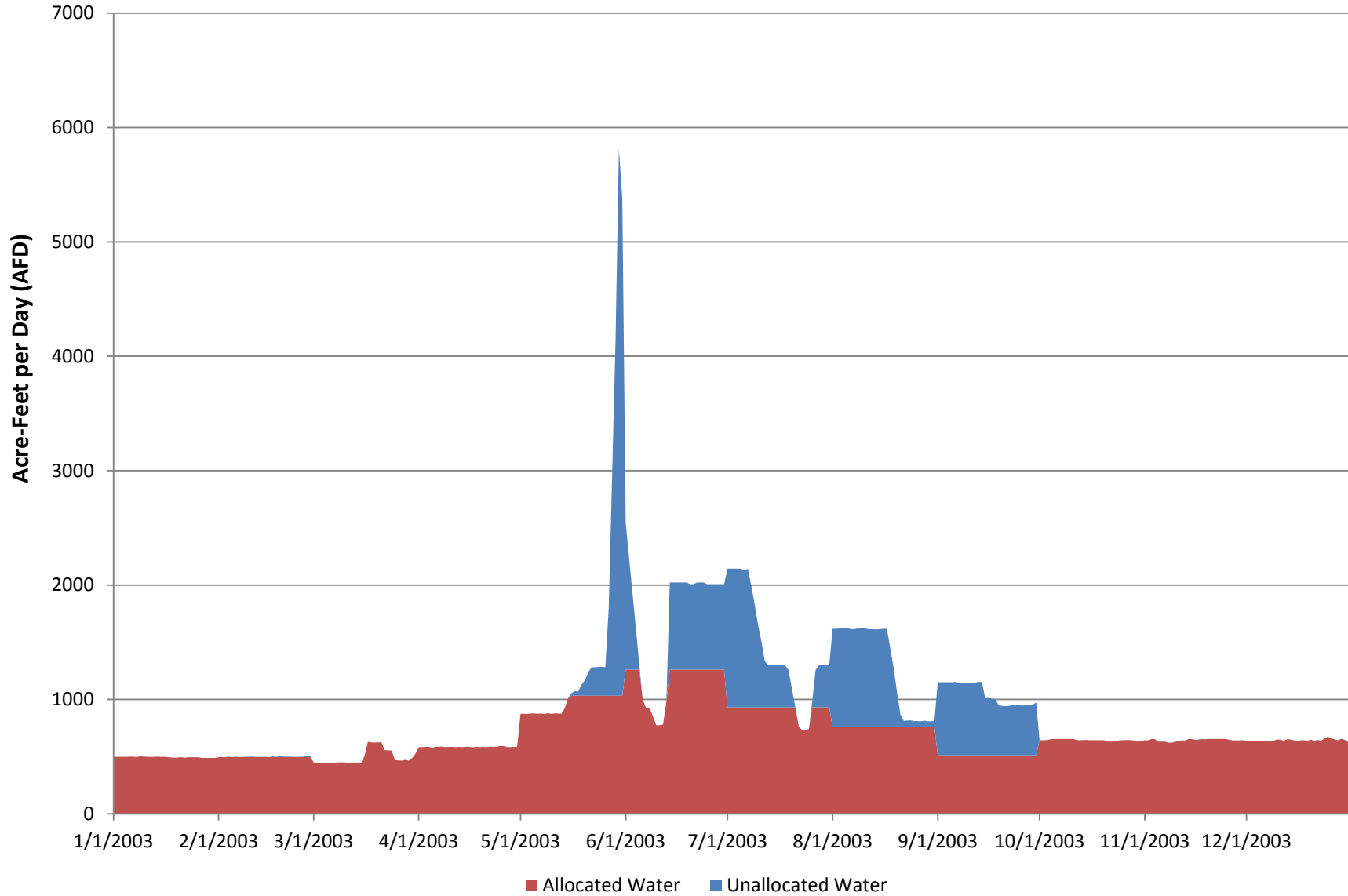
**Figure H-3: Daily Unallocated Water Calculation Downstream of Camanche Reservoir - 2001 hydrology (2010 diversion assumptions)**



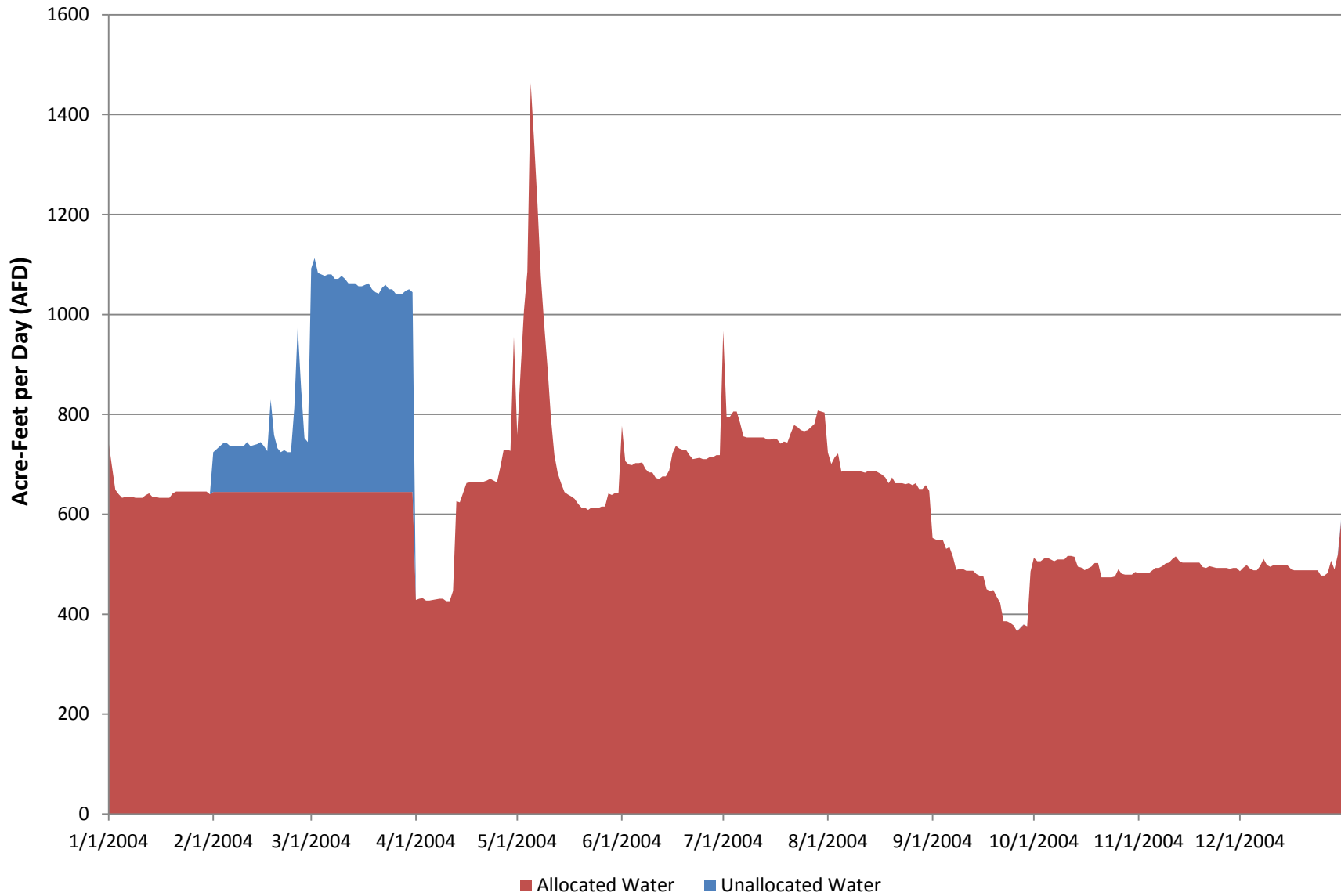
**Figure H-4: Daily Unallocated Water Calculation Downstream of Camanche Reservoir - 2002 hydrology (2010 diversion assumptions)**



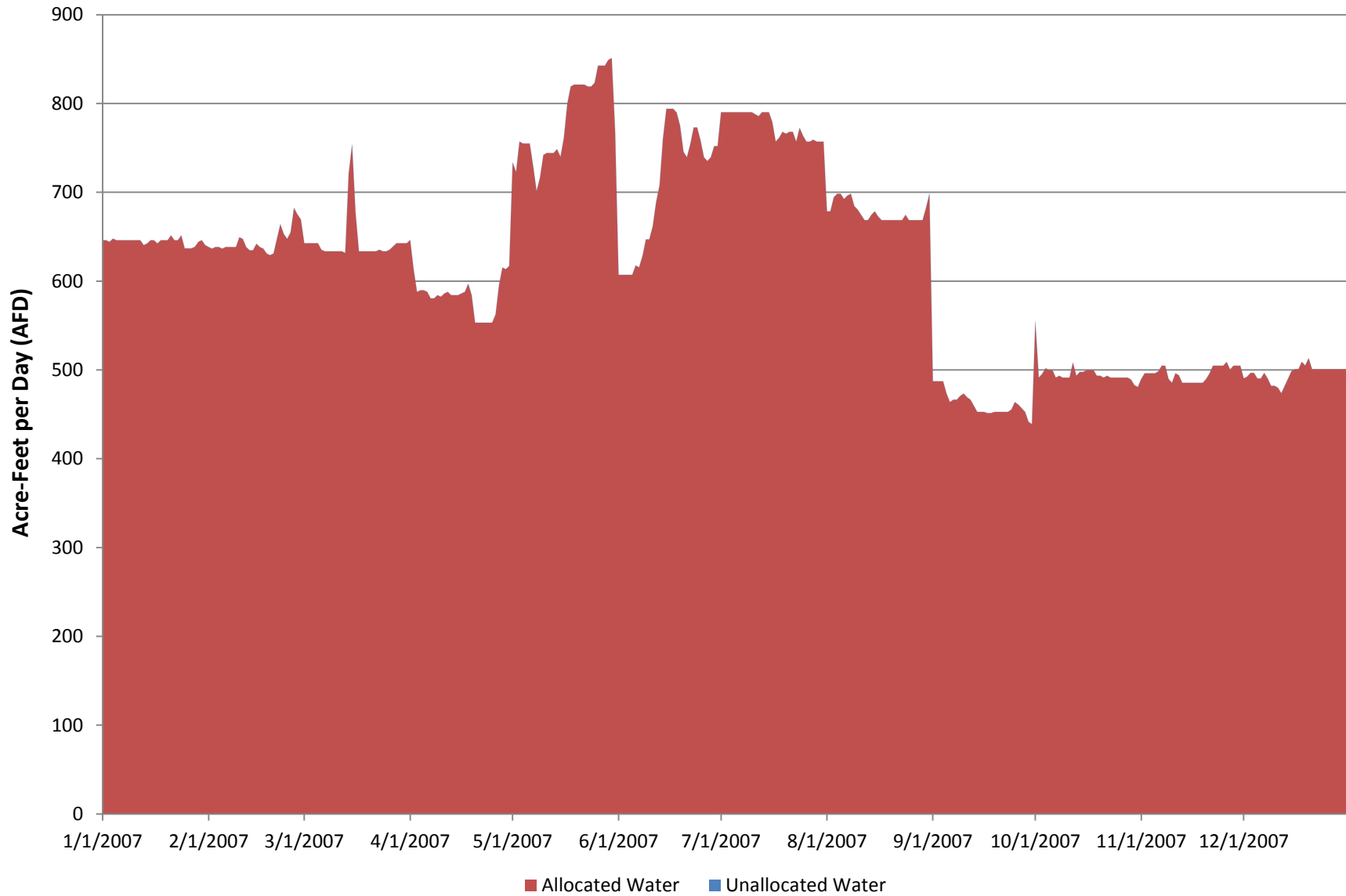
**Figure H-5: Daily Unallocated Water Calculation Downstream of Camanche Reservoir - 2003 hydrology (2010 diversion assumptions)**



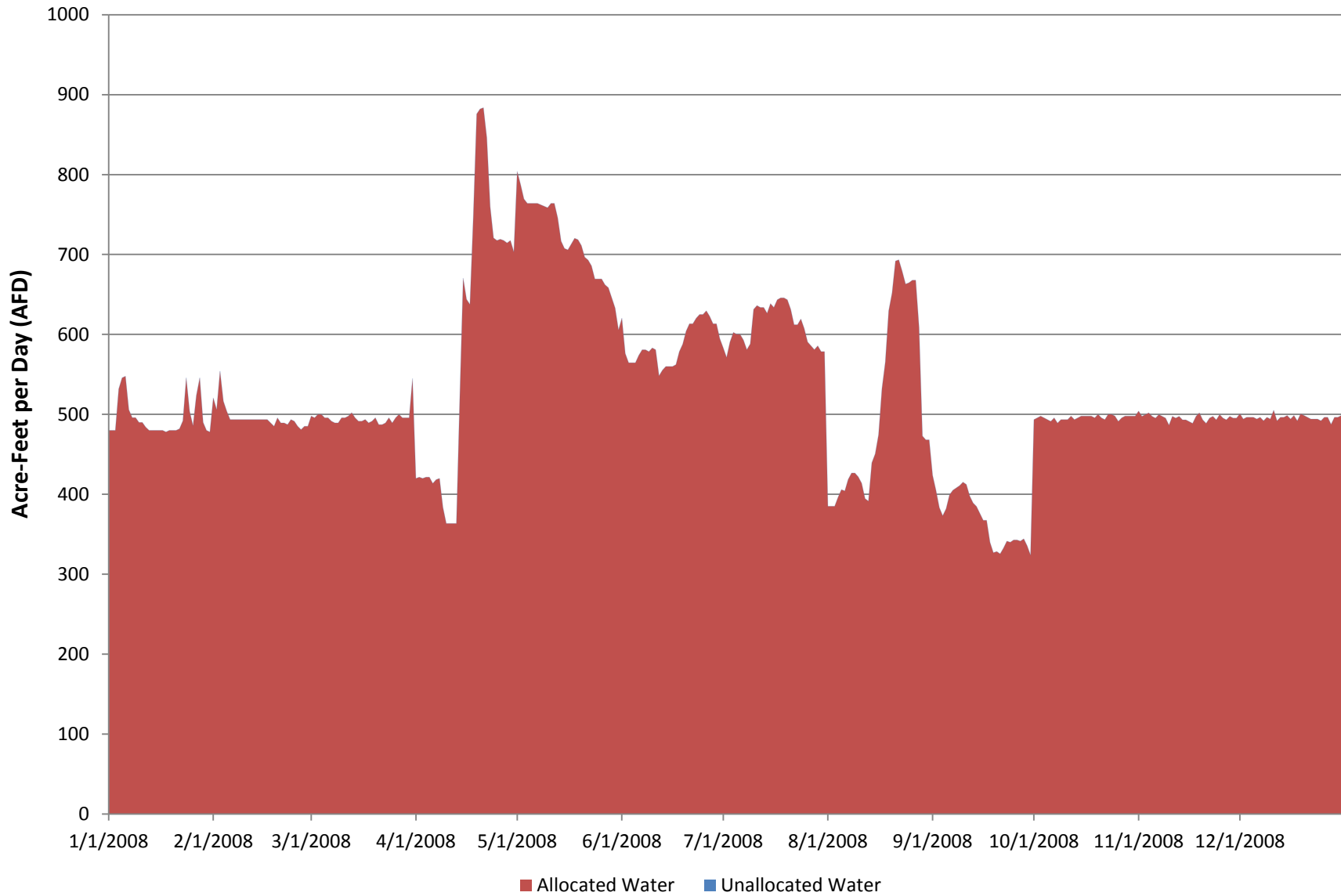
**Figure H-6: Daily Unallocated Water Calculation Downstream of Camanche Reservoir - 2004 hydrology (2010 diversion assumptions)**



**Figure H-7: Daily Unallocated Water Calculation Downstream of Camanche Reservoir - 2007 hydrology (2010 diversion assumptions)**

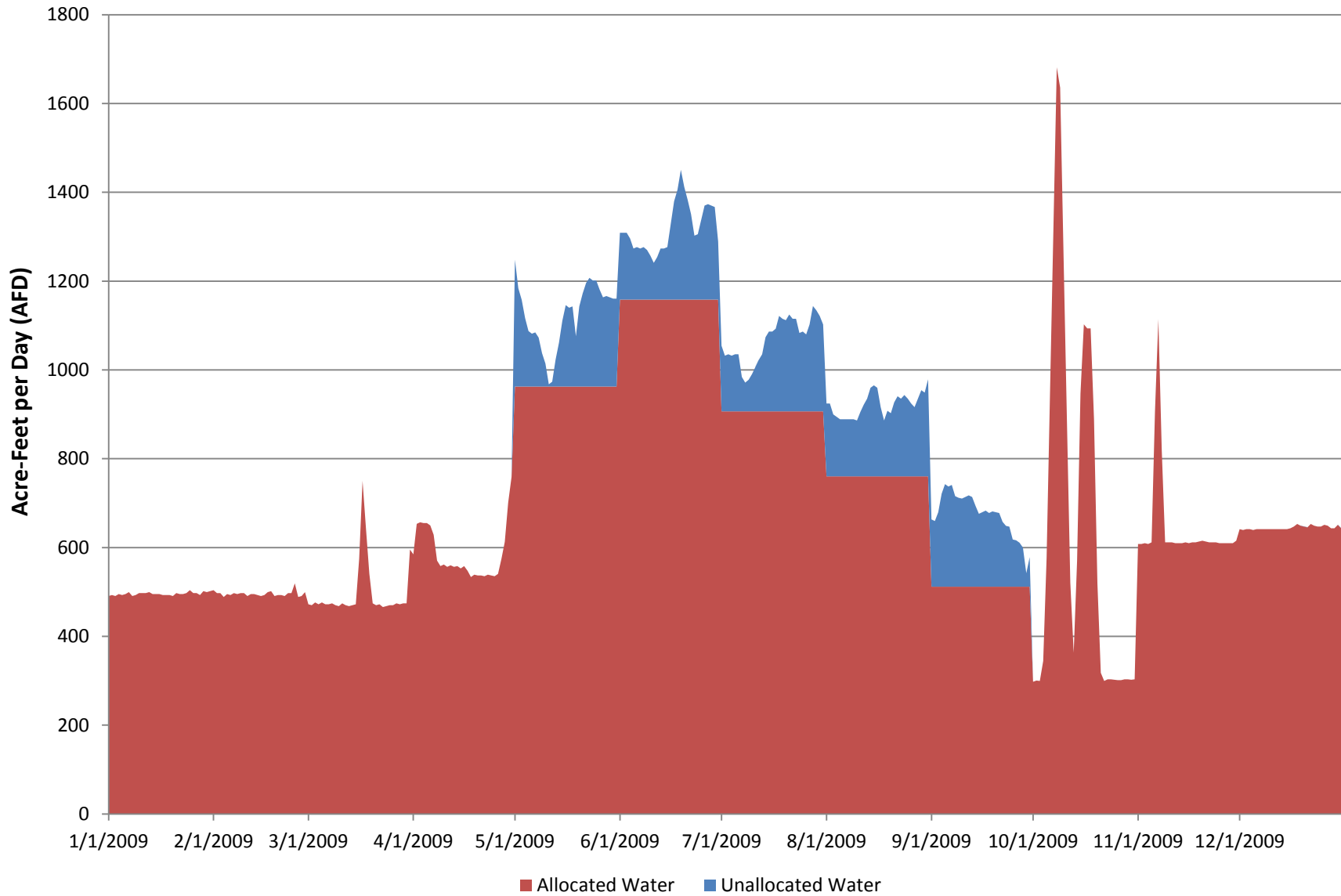


**Figure H-8: Daily Unallocated Water Calculation Downstream of Camanche Reservoir - 2008 hydrology (2010 diversion assumptions)**

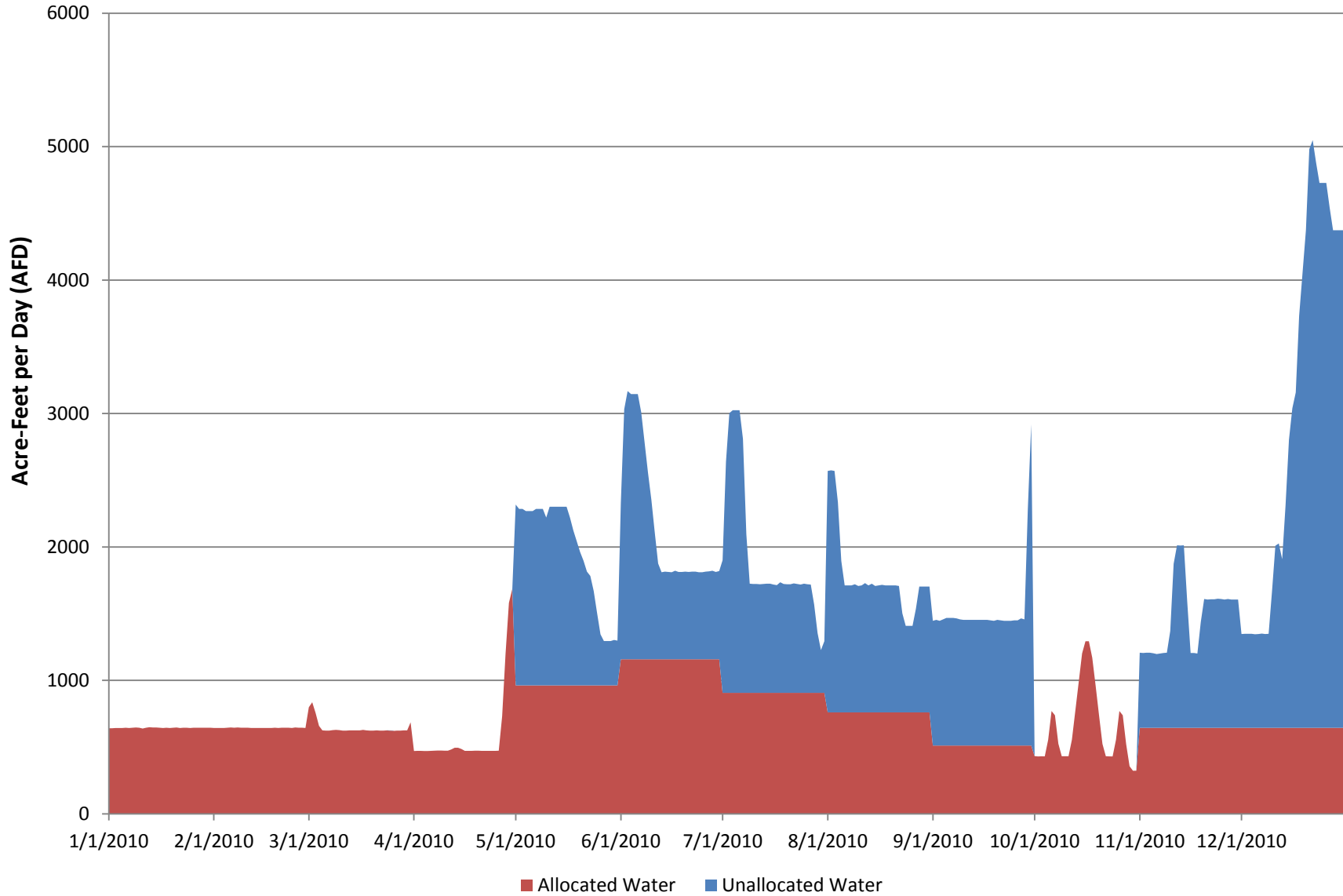




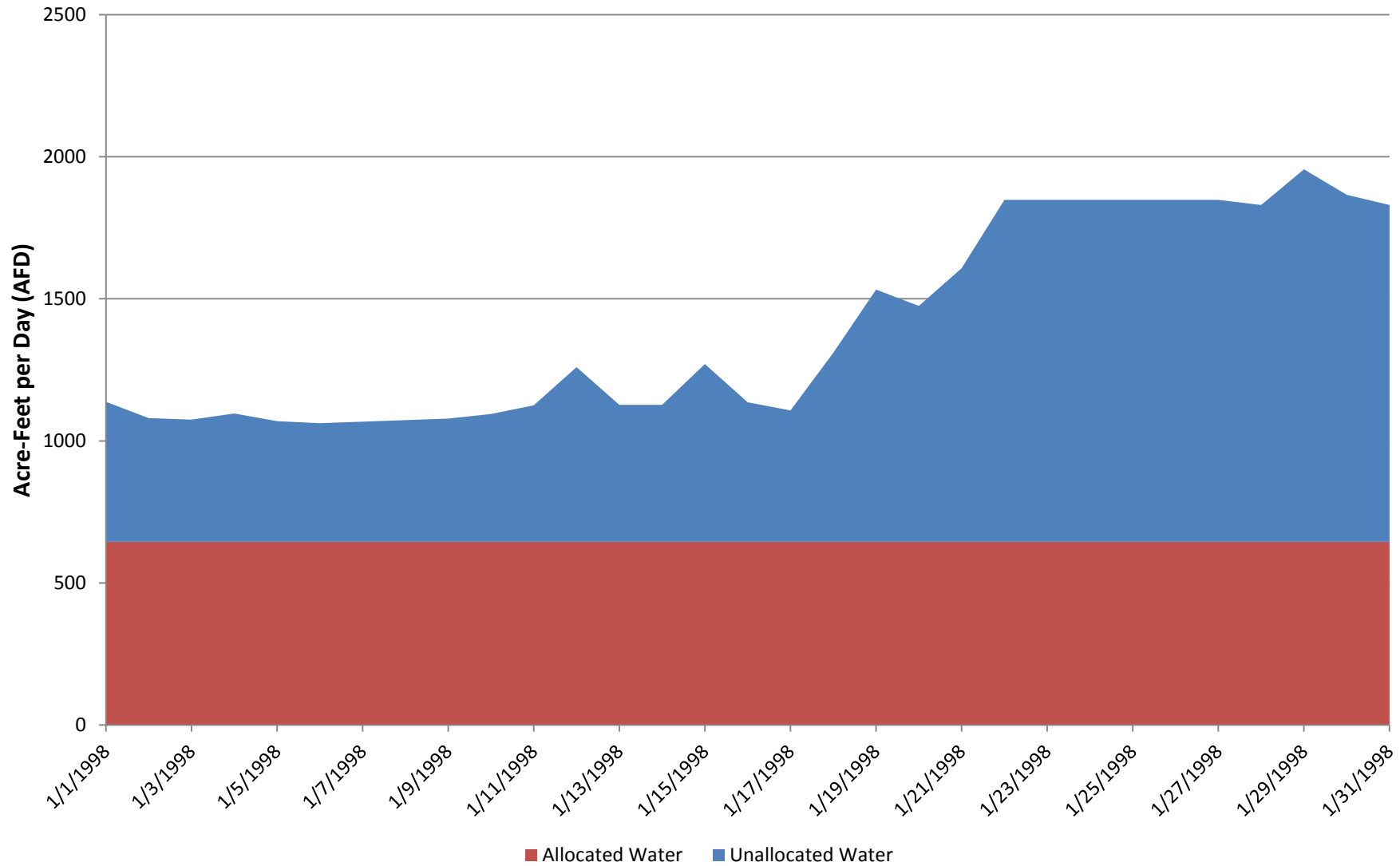
**Figure H-9: Daily Unallocated Water Calculation Downstream of Camanche Reservoir - 2009 hydrology (2010 diversion assumptions)**



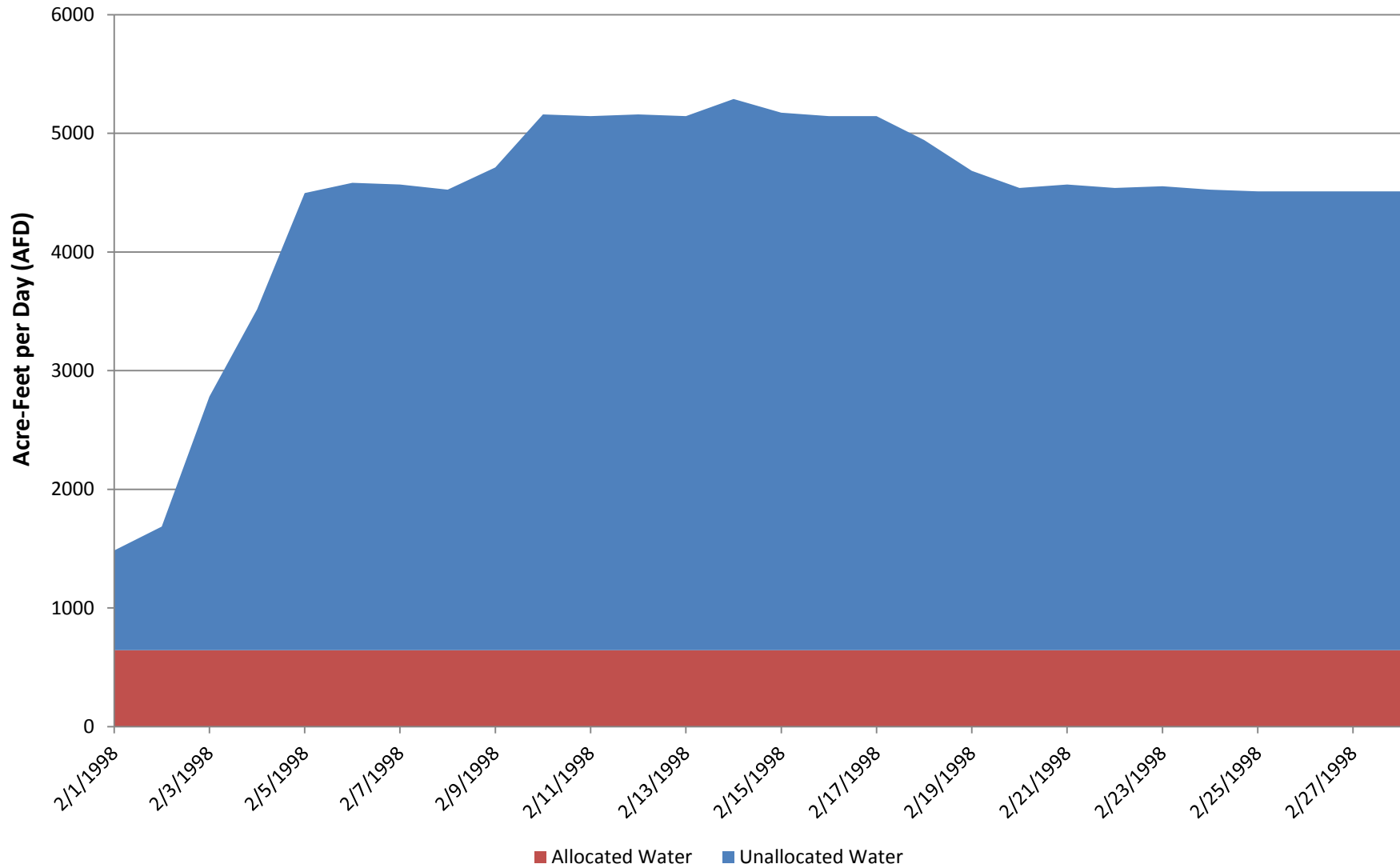
**Figure H-10: Daily Unallocated Water Calculation Downstream of Camanche Reservoir - 2010 hydrology (2010 diversion assumptions)**



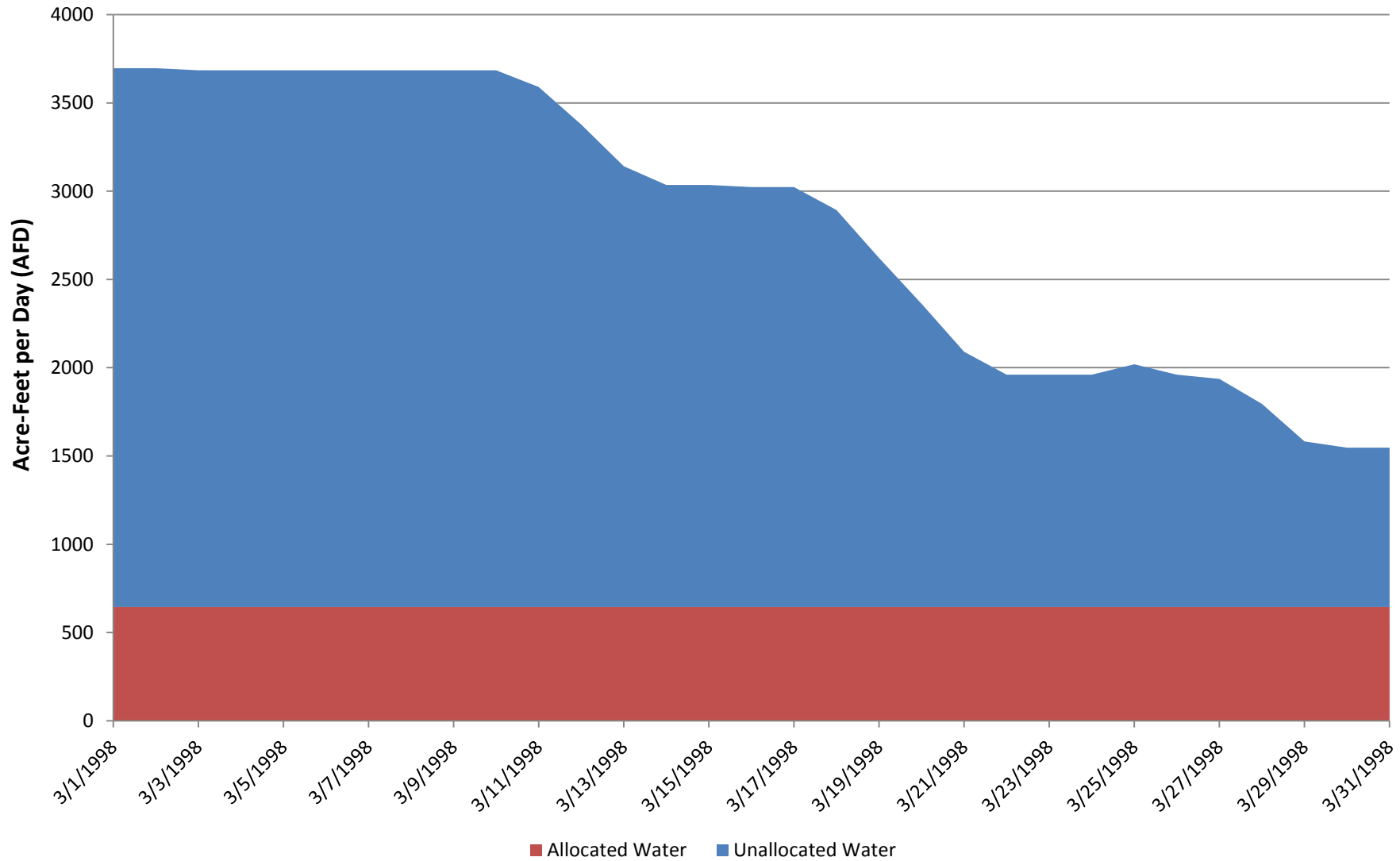
**Figure H-11: Daily Unallocated Water Calculation Downstream of Camanche Reservoir - January 1998 hydrology (2010 diversion assumptions)**



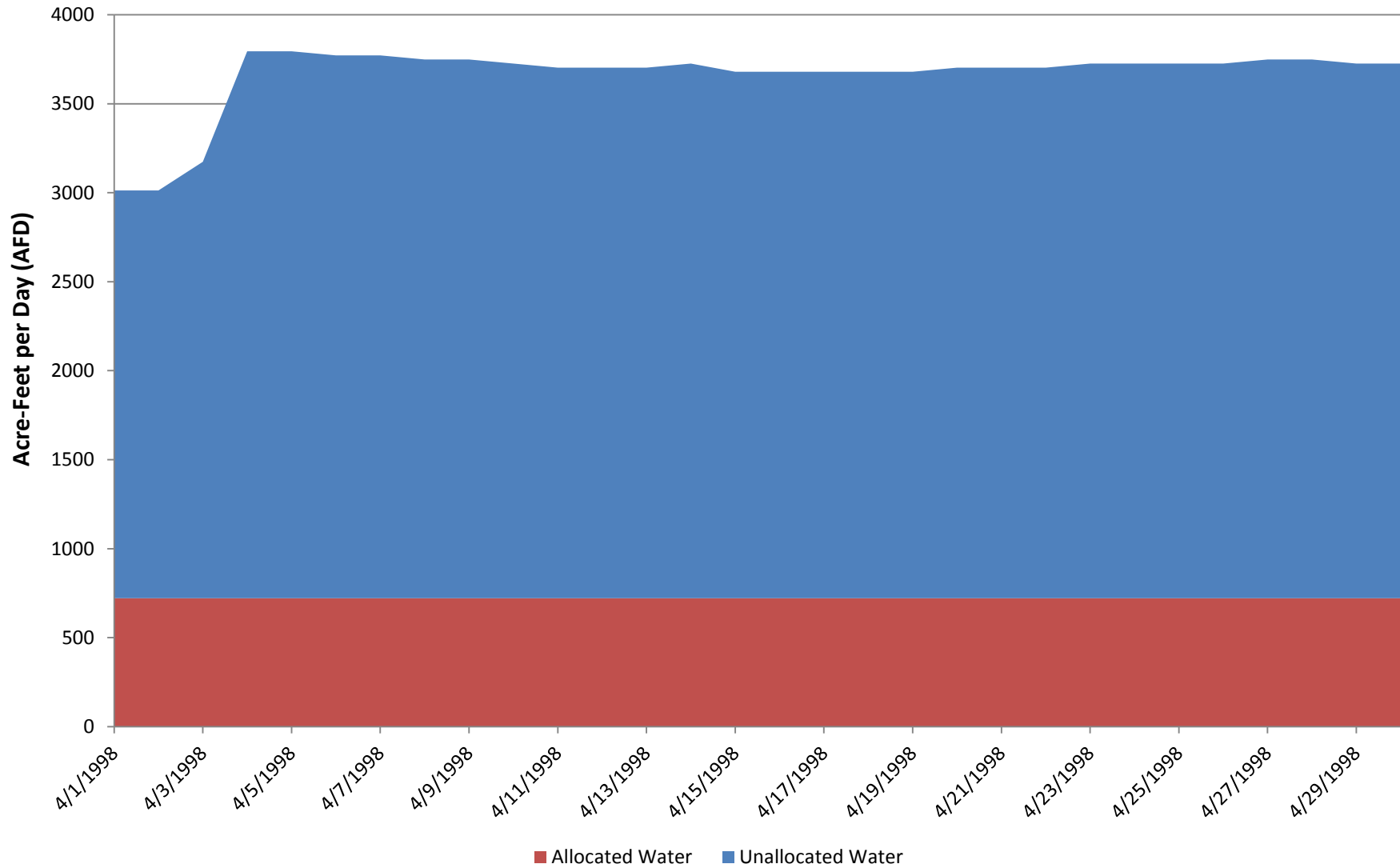
**Figure H-12: Daily Unallocated Water Calculation Downstream of Camanche Reservoir - February 1998 hydrology (2010 diversion assumptions)**



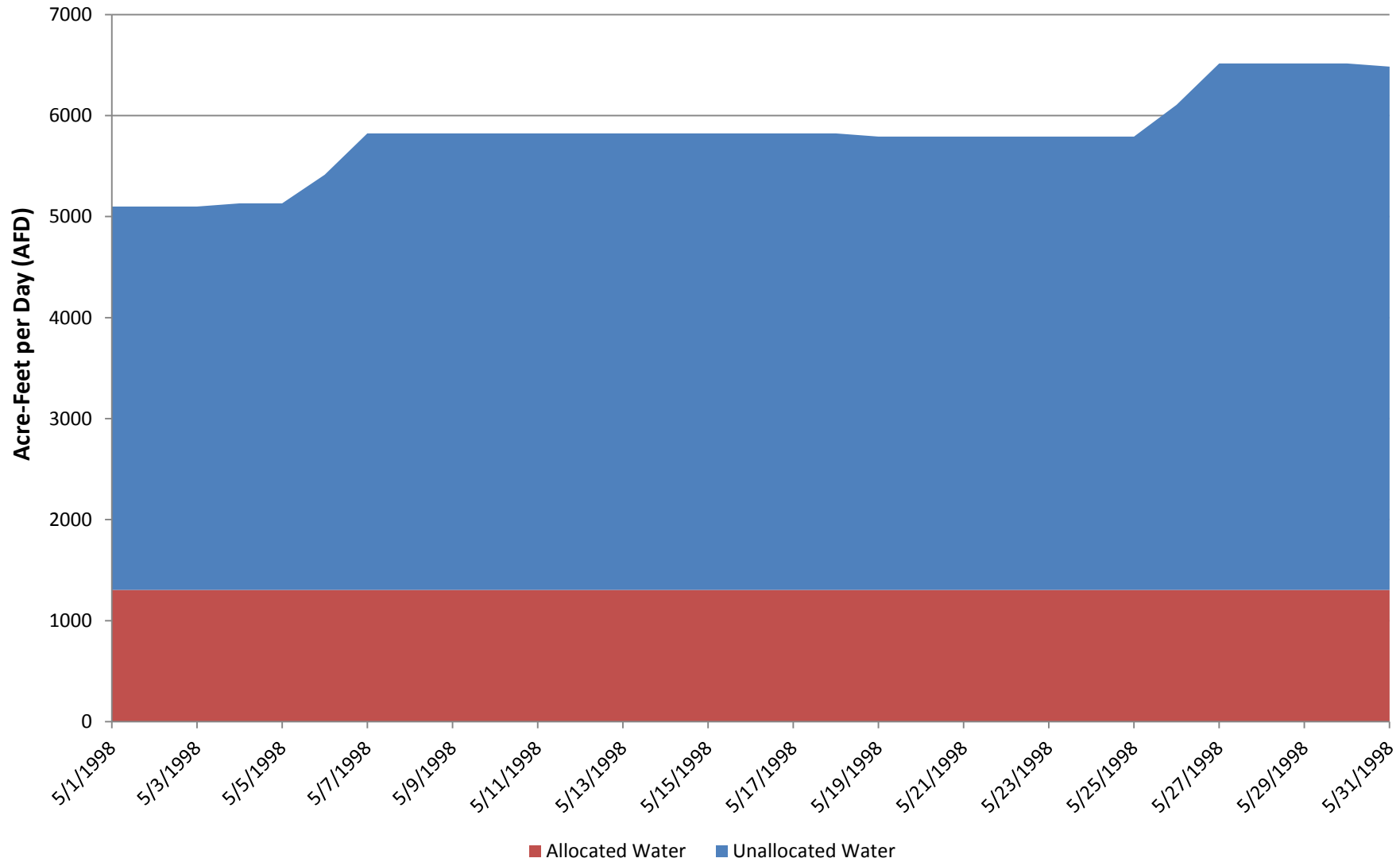
**Figure H-13: Daily Unallocated Water Calculation Downstream of Camanche Reservoir - March 1998 hydrology (2010 diversion assumptions)**



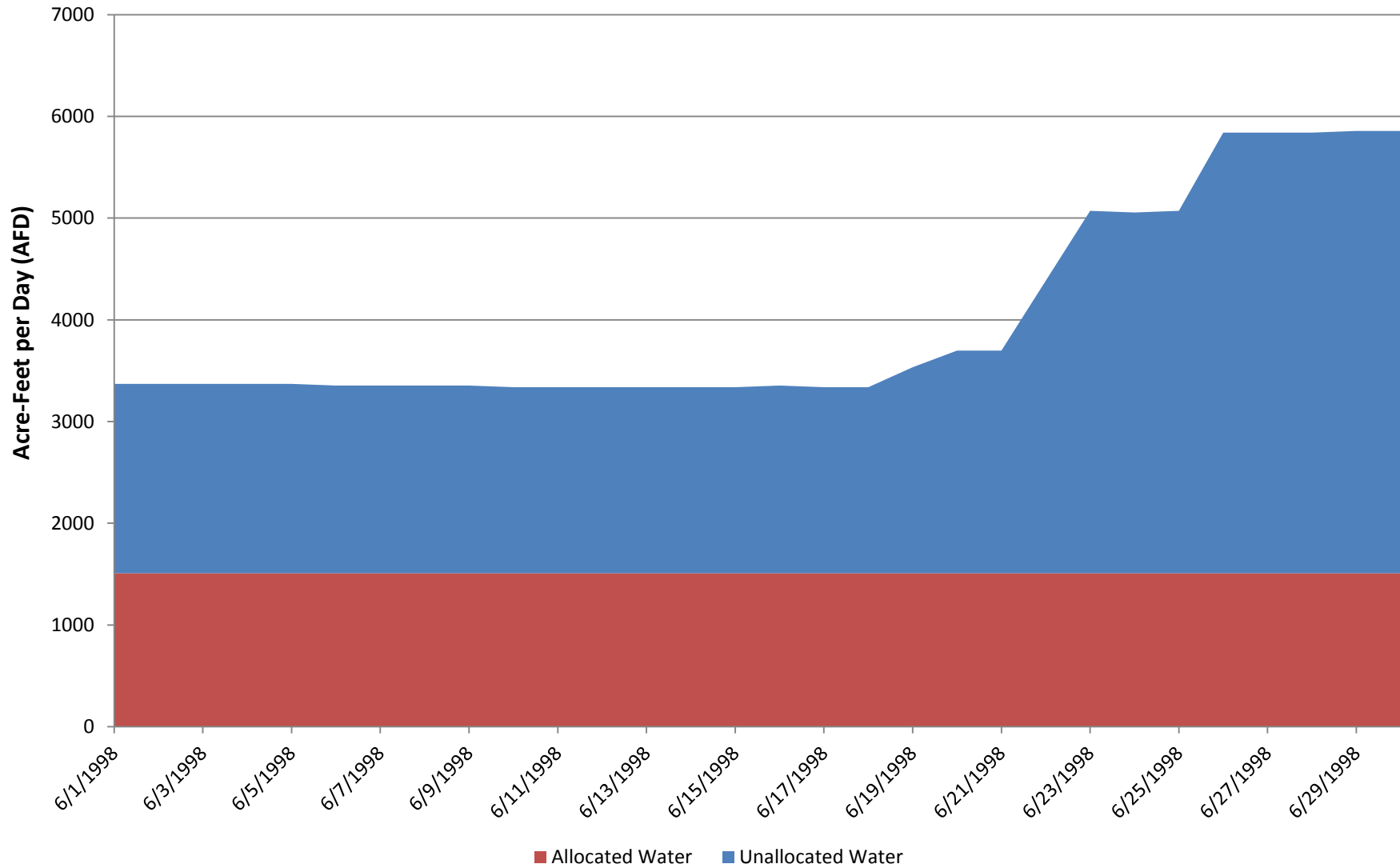
**Figure H-14: Daily Unallocated Water Calculation Downstream of Camanche Reservoir - April 1998 hydrology (2010 diversion assumptions)**



**Figure H-15: Daily Unallocated Water Calculation Downstream of Camanche Reservoir - May 1998 hydrology (2010 diversion assumptions)**

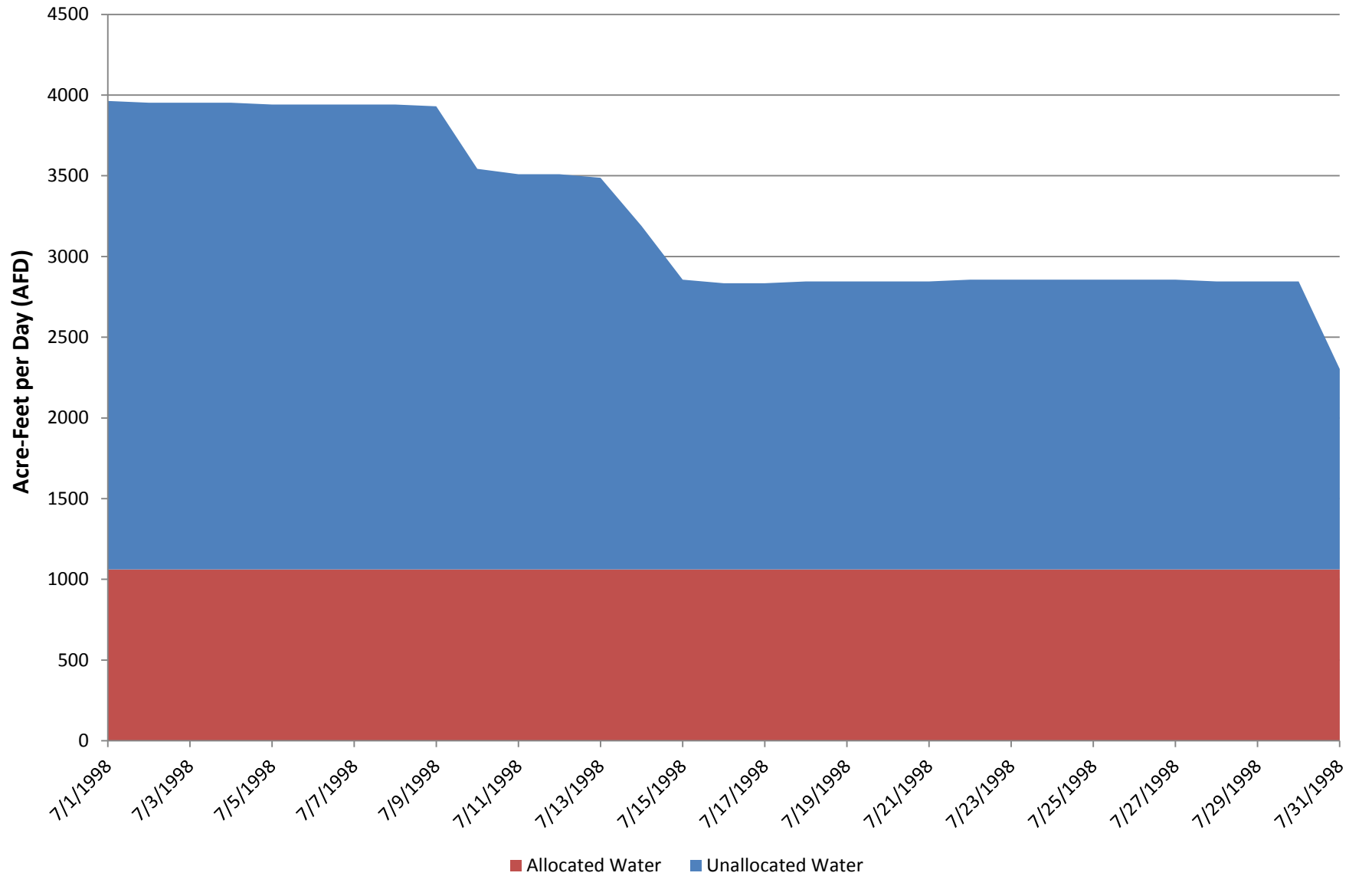


**Figure H-16: Daily Unallocated Water Calculation Downstream of Camanche Reservoir - June 1998 hydrology (2010 diversion assumptions)**

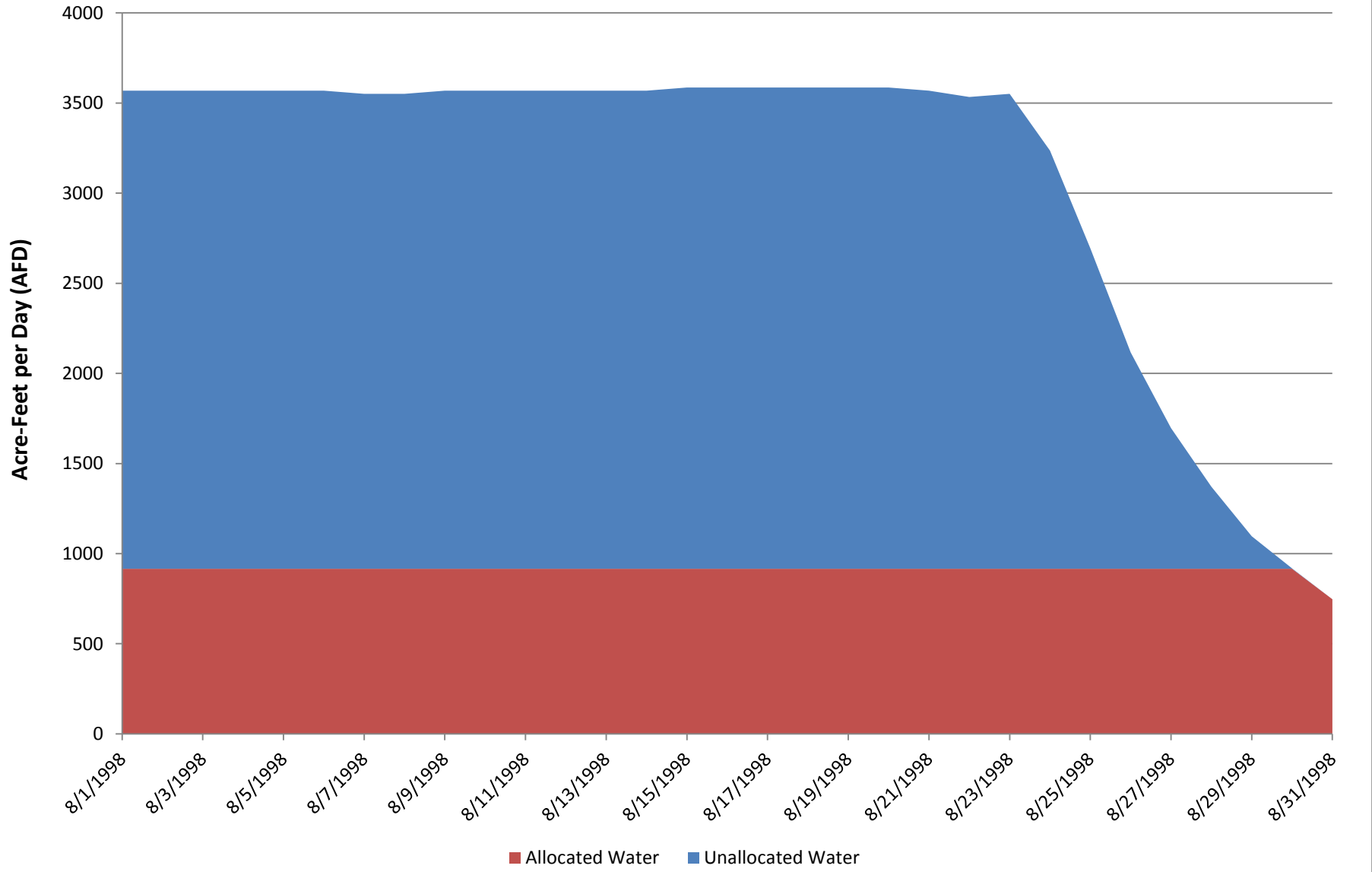




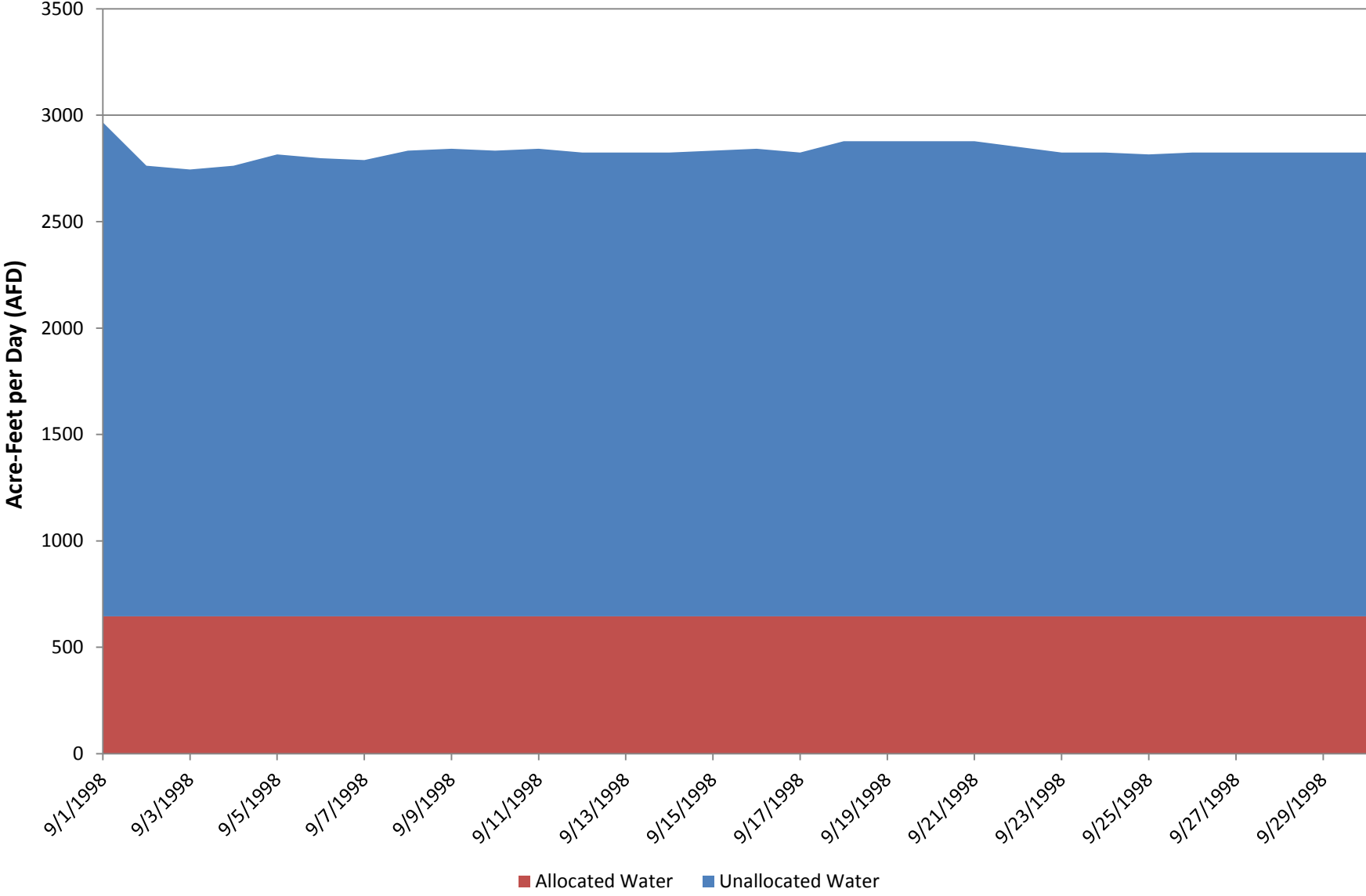
**Figure H-17: Daily Unallocated Water Calculation Downstream of Camanche Reservoir - July 1998 hydrology (2010 diversion assumptions)**



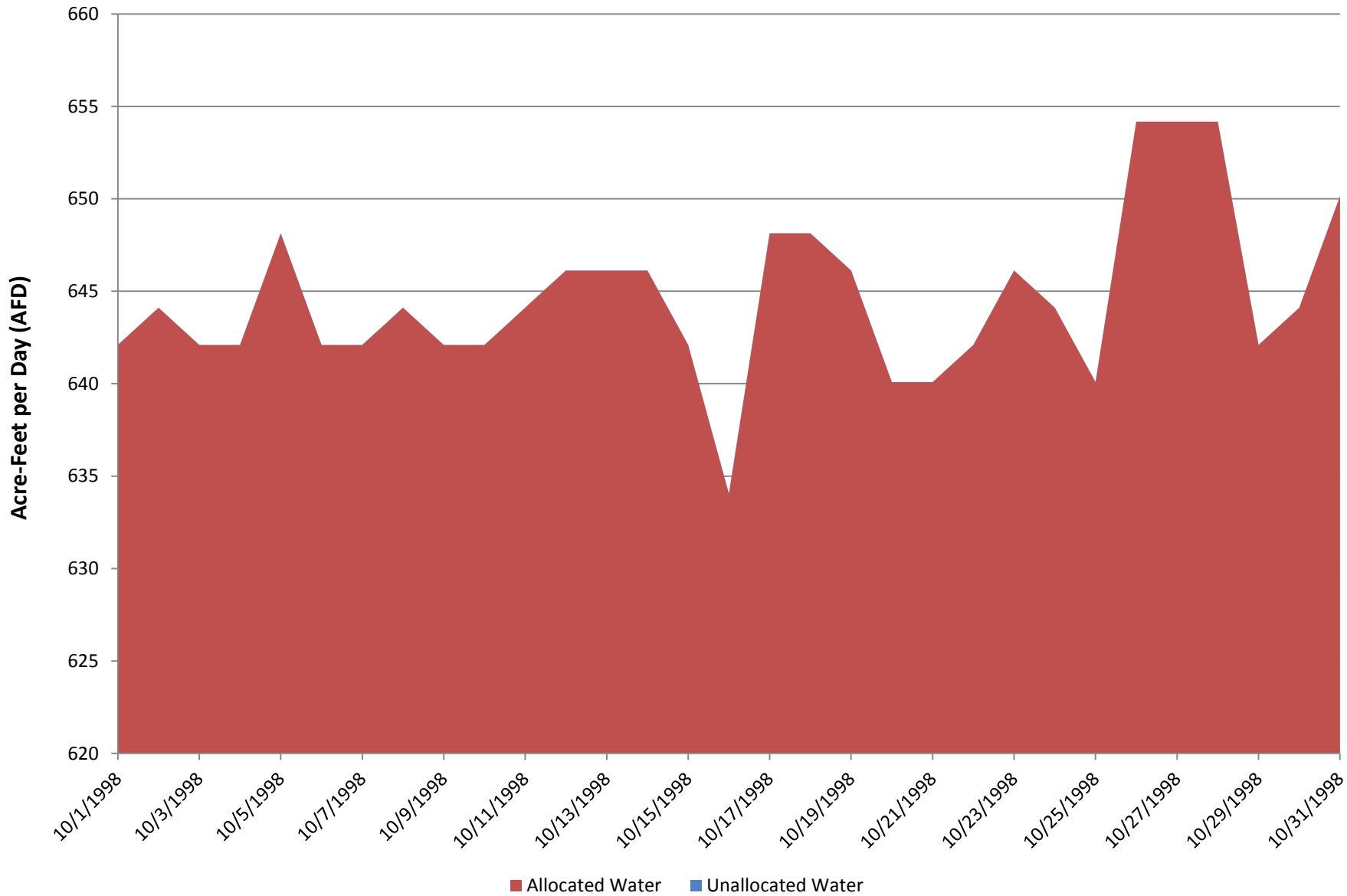
**Figure H-18: Daily Unallocated Water Calculation Downstream of Camanche Reservoir - August 1998 hydrology (2010 diversion assumptions)**



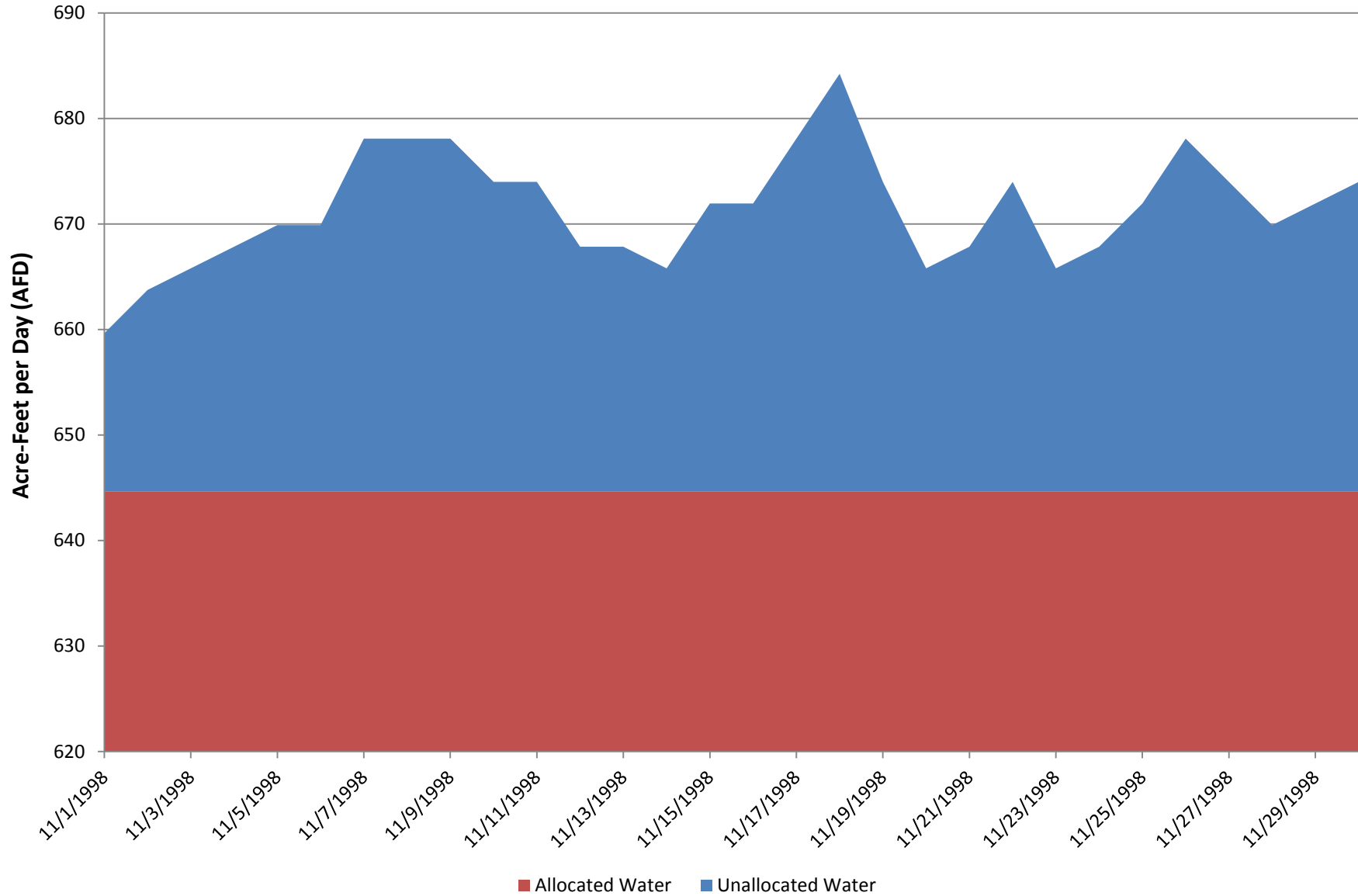
**Figure H-19: Daily Unallocated Water Calculation Downstream of Camanche Reservoir - September 1998 hydrology (2010 diversion assumptions)**



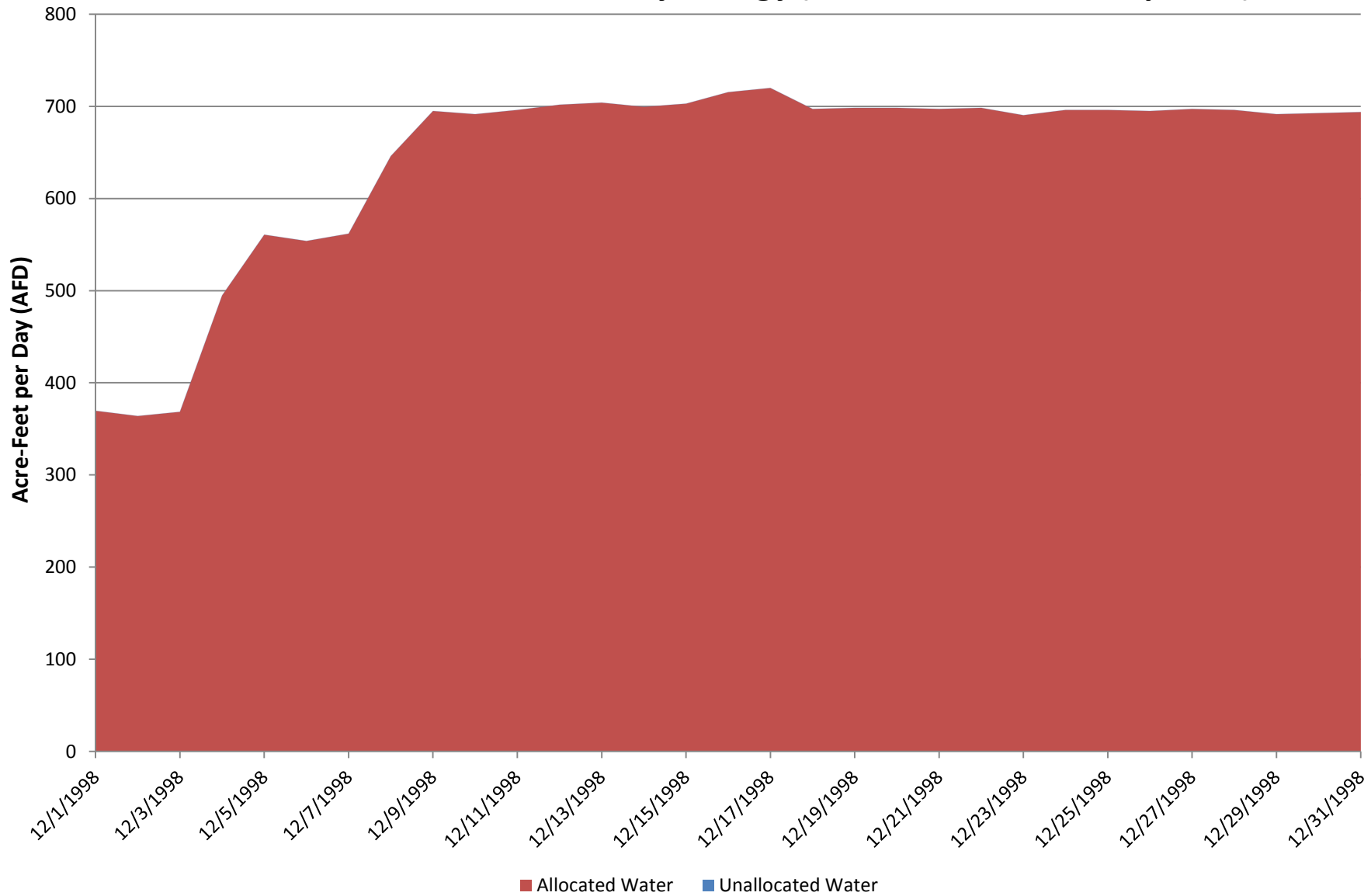
**Figure H-20: Daily Unallocated Water Calculation Downstream of Camanche Reservoir - October 1998 hydrology (2010 diversion assumptions)**



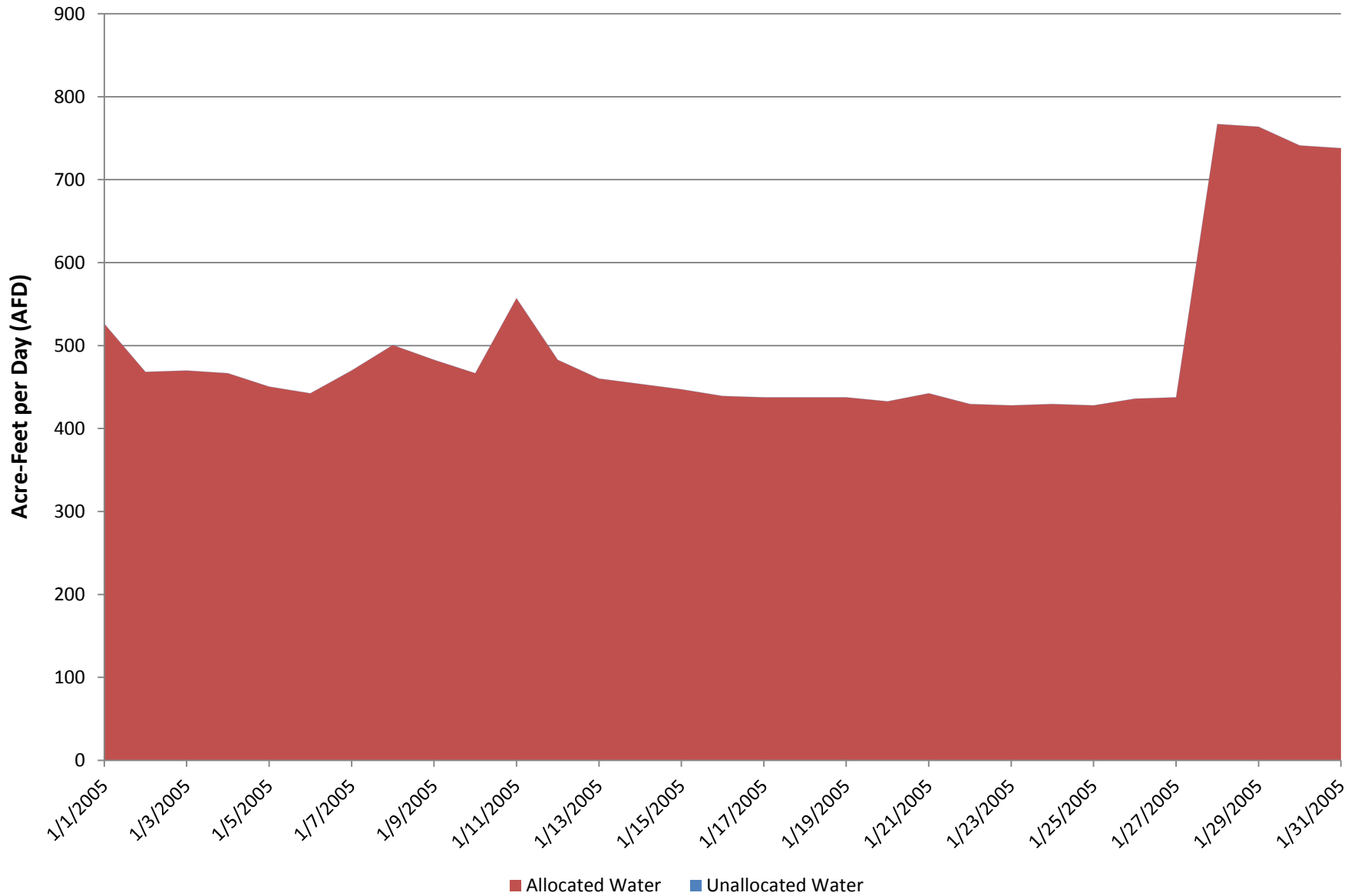
**Figure H-21: Daily Unallocated Water Calculation Downstream of Camanche Reservoir - November 2011 hydrology (2010 diversion assumptions)**



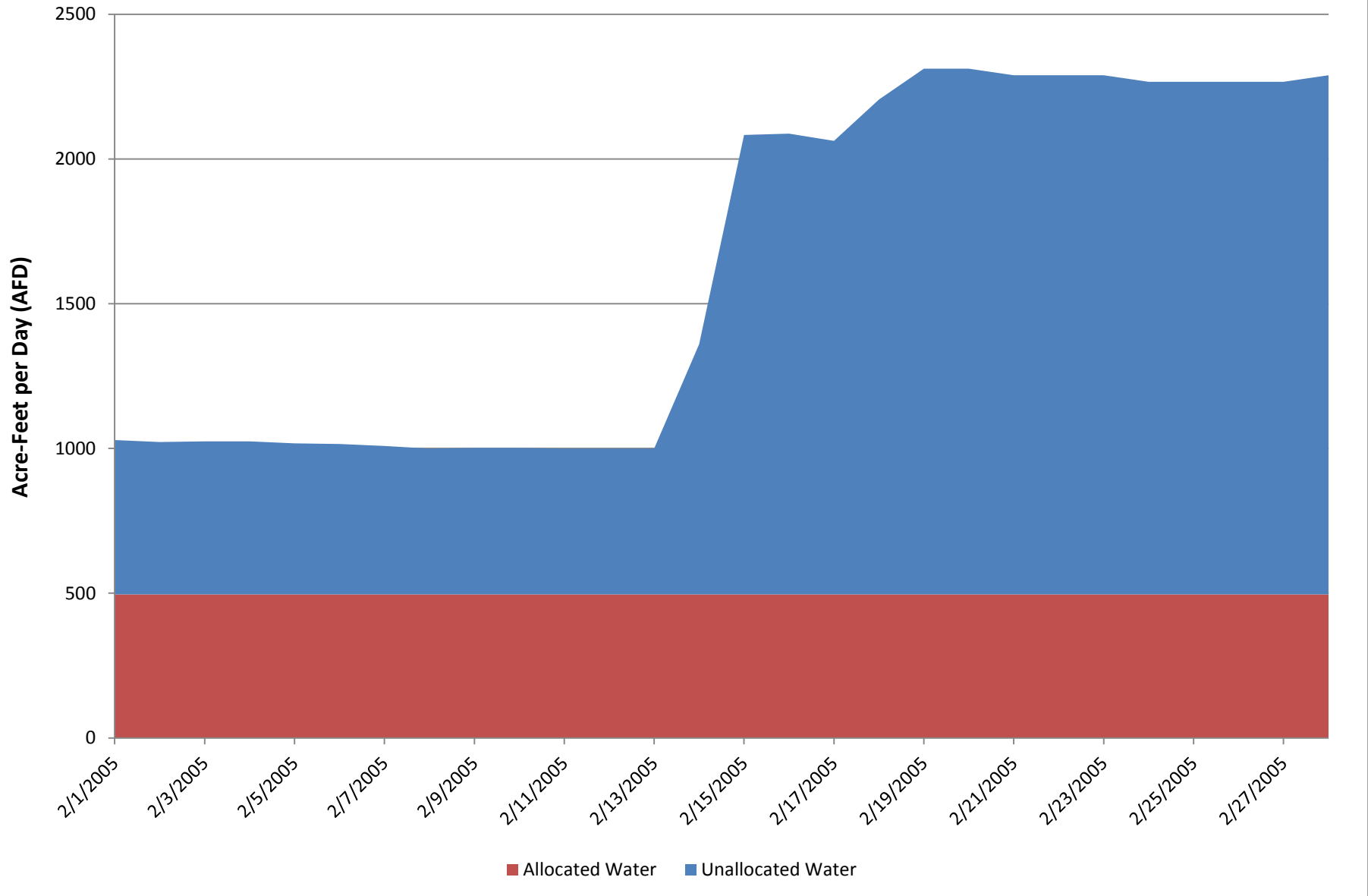
**Figure H-22: Daily Unallocated Water Calculation Downstream of Camanche Reservoir - December 1998 hydrology (2010 diversion assumptions)**



**Figure H-23: Daily Unallocated Water Calculation Downstream of Camanche Reservoir - January 2005 hydrology (2010 diversion assumptions)**

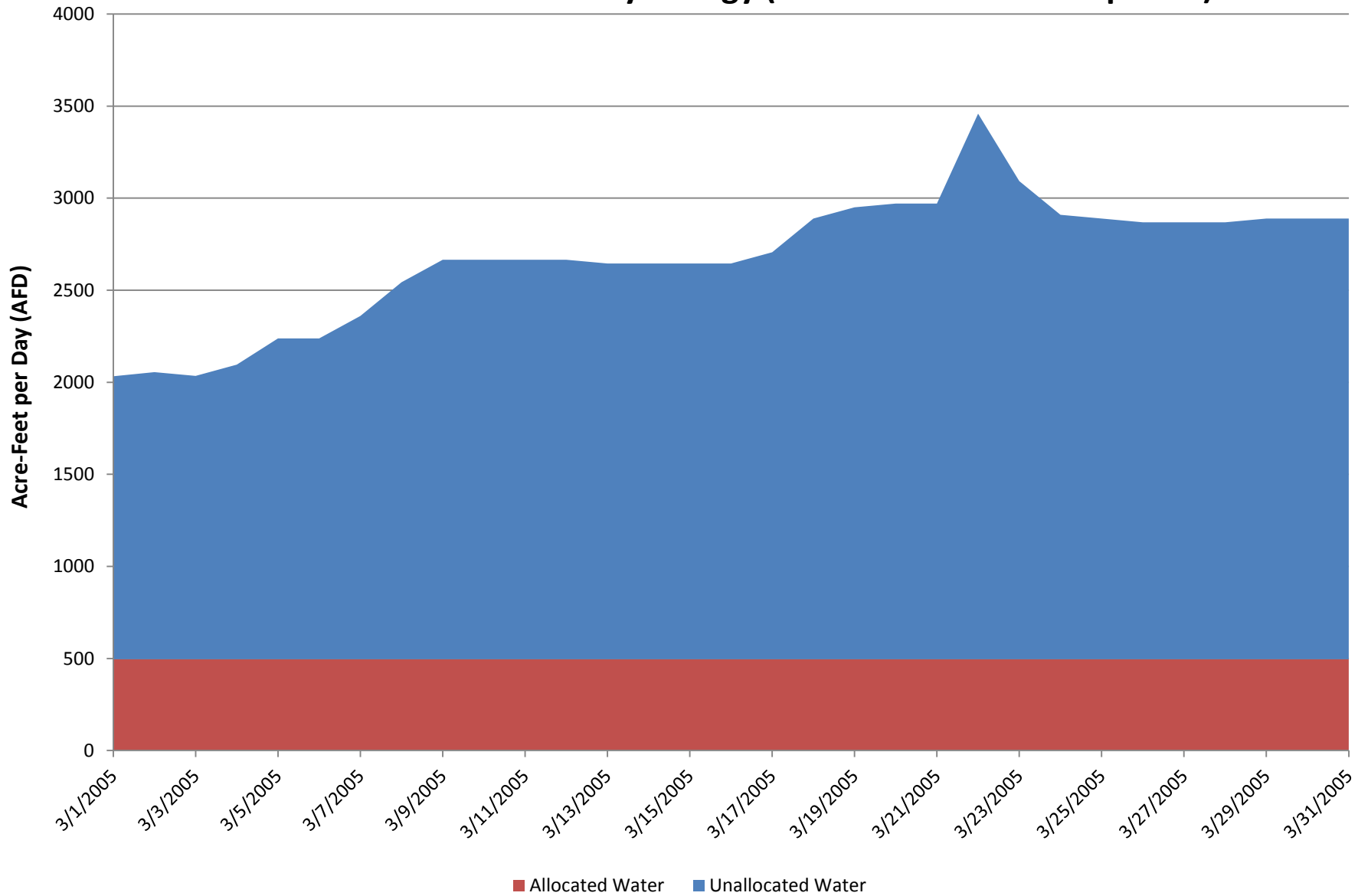


**Figure H-24: Daily Unallocated Water Calculation Downstream of Camanche Reservoir - February 2005 (2010 diversion assumptions)**

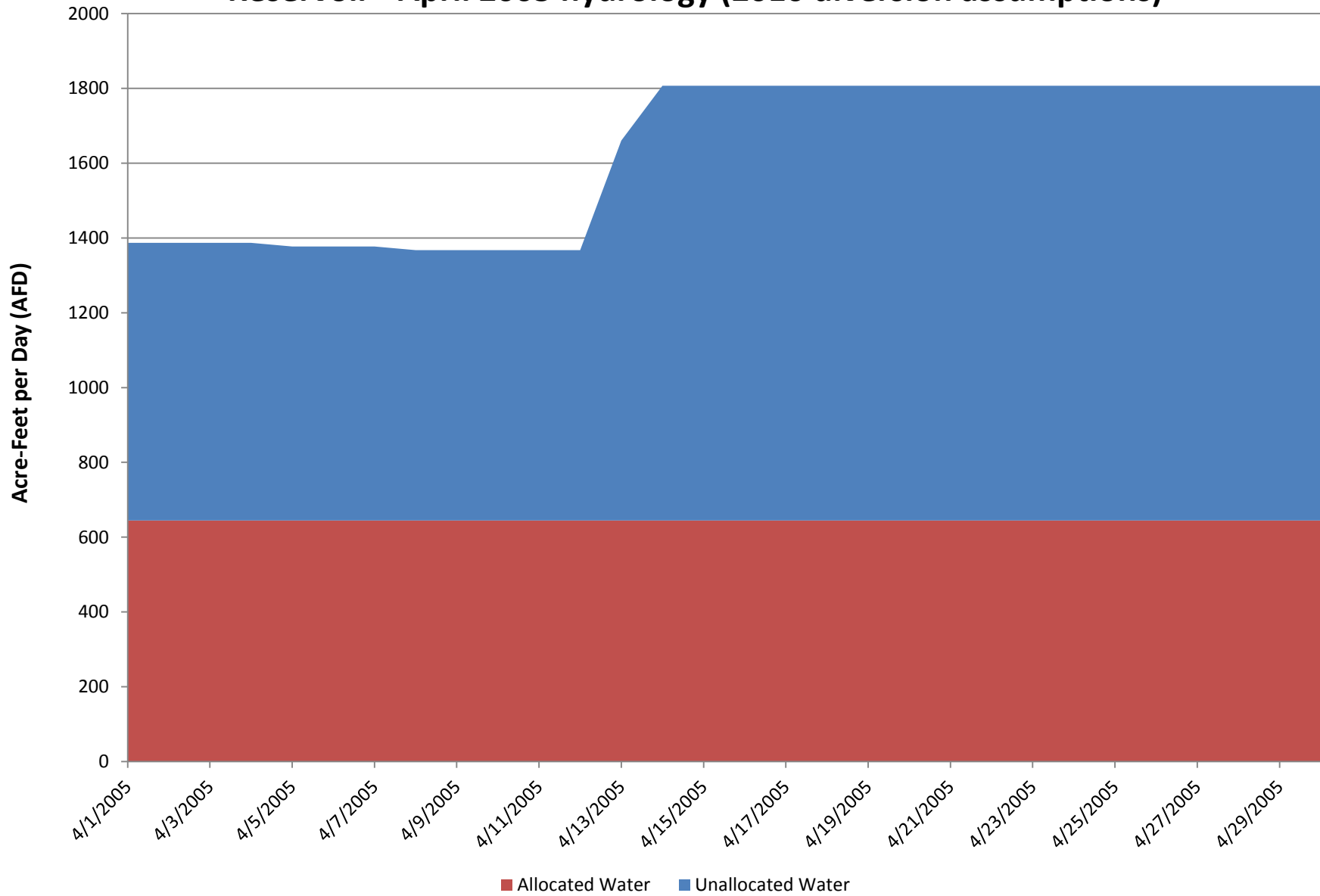




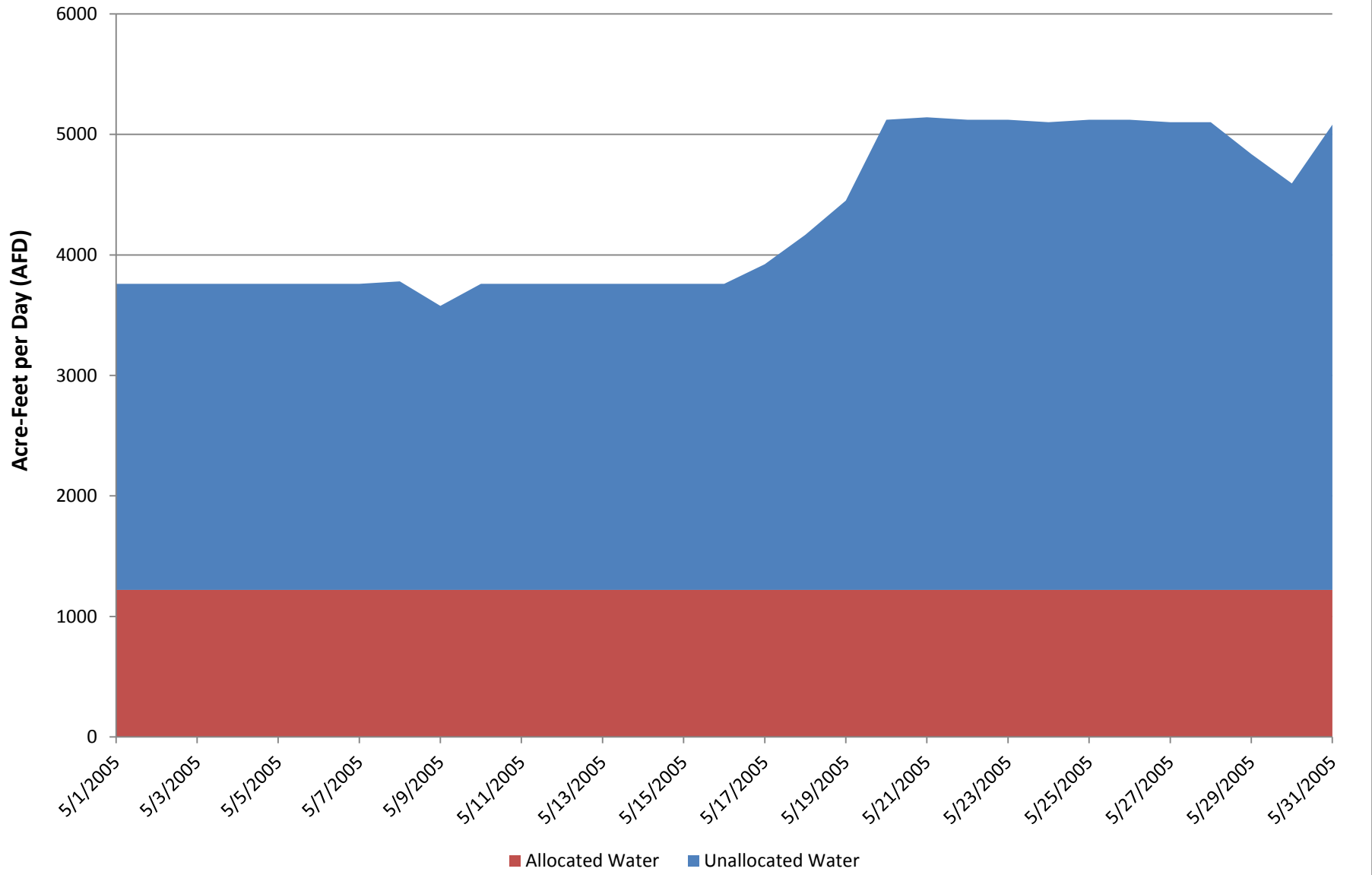
**Figure H-25: Daily Unallocated Water Calculation Downstream of Camanche Reservoir - March 2005 hydrology (2010 diversion assumptions)**



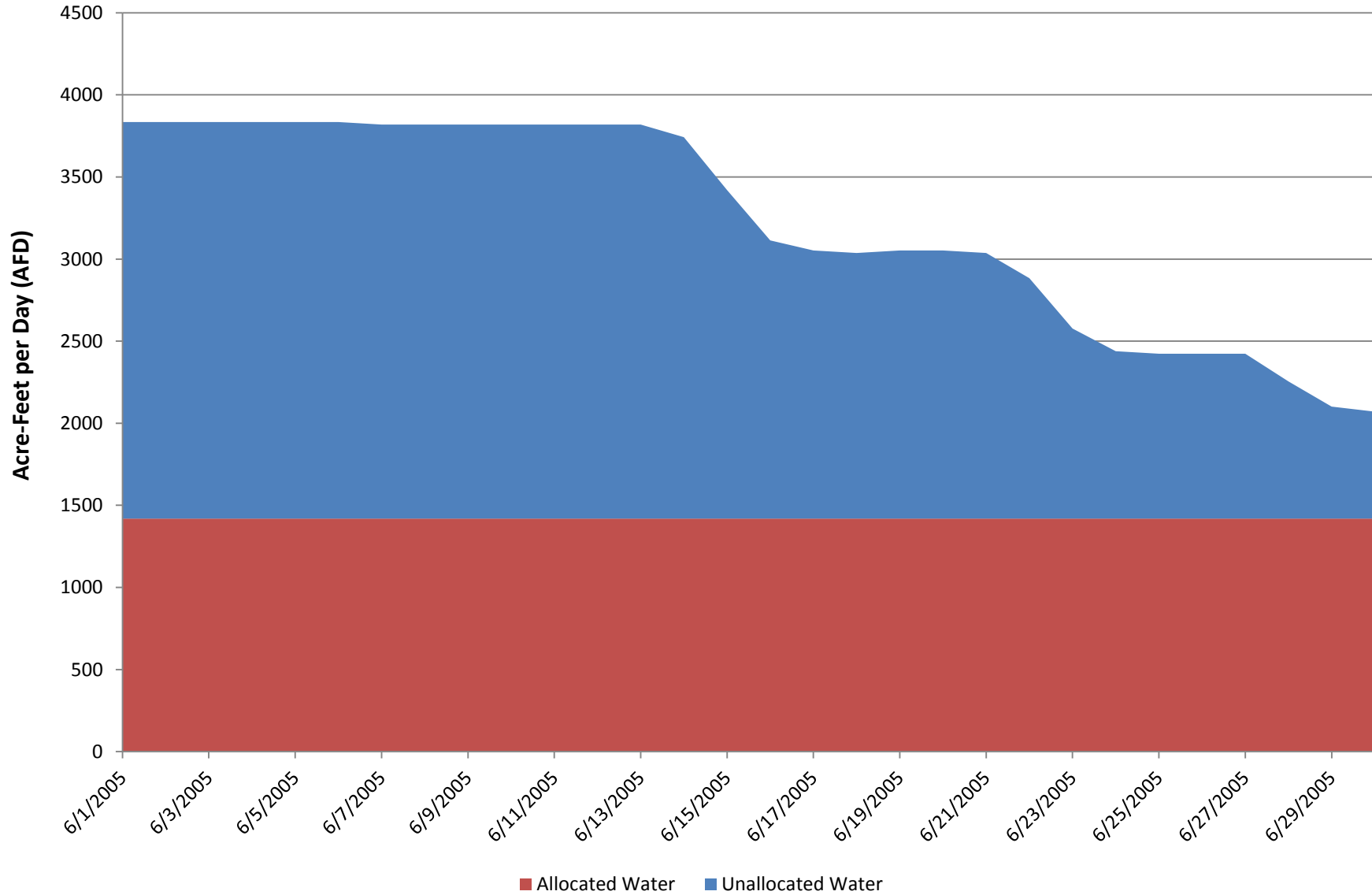
**Figure H-26: Daily Unallocated Water Calculation Downstream of Camanche Reservoir - April 2005 hydrology (2010 diversion assumptions)**



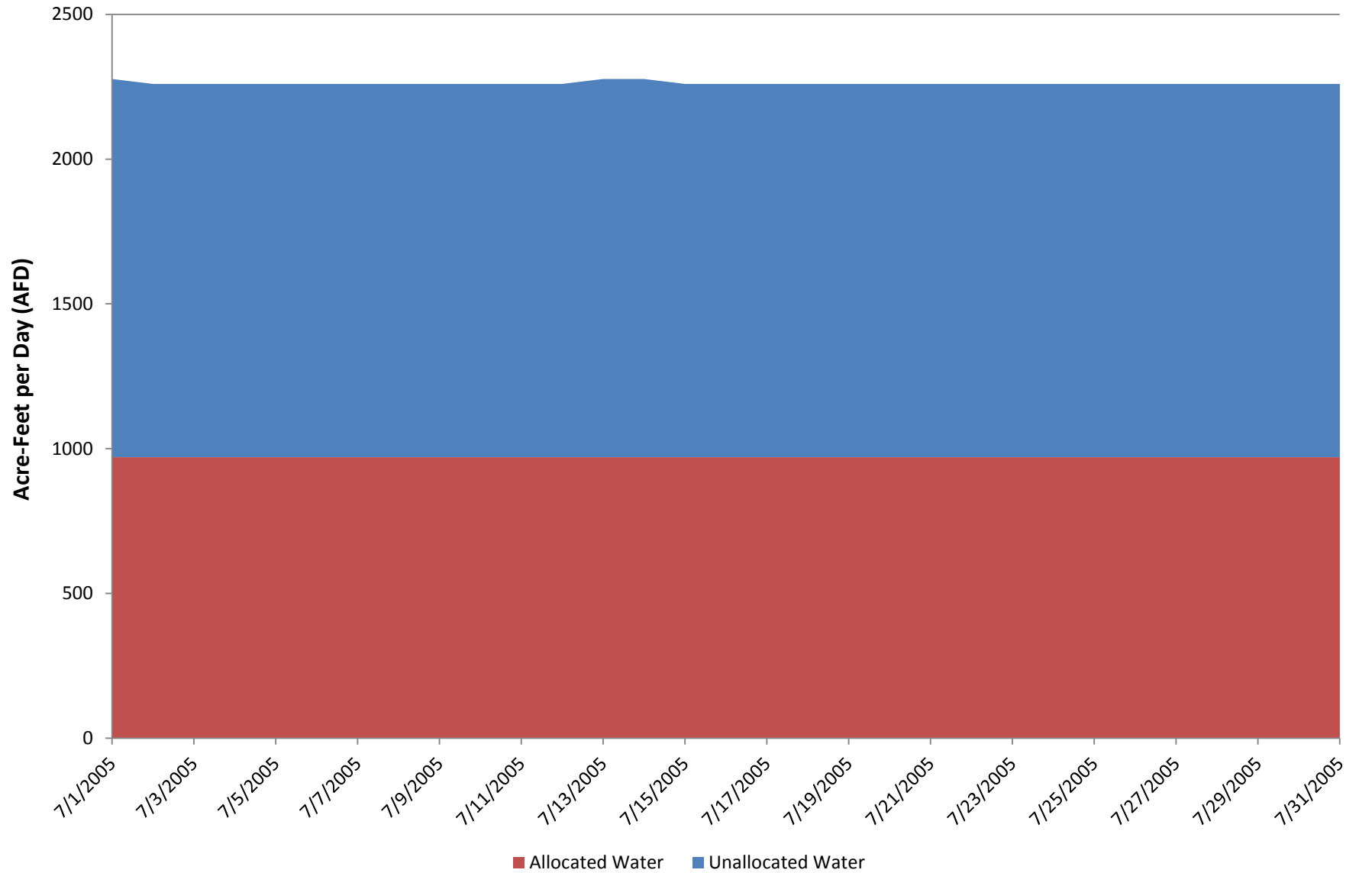
**Figure H-27: Daily Unallocated Water Calculation Downstream of Camanche Reservoir - May 2005 hydrology (2010 diversion assumptions)**



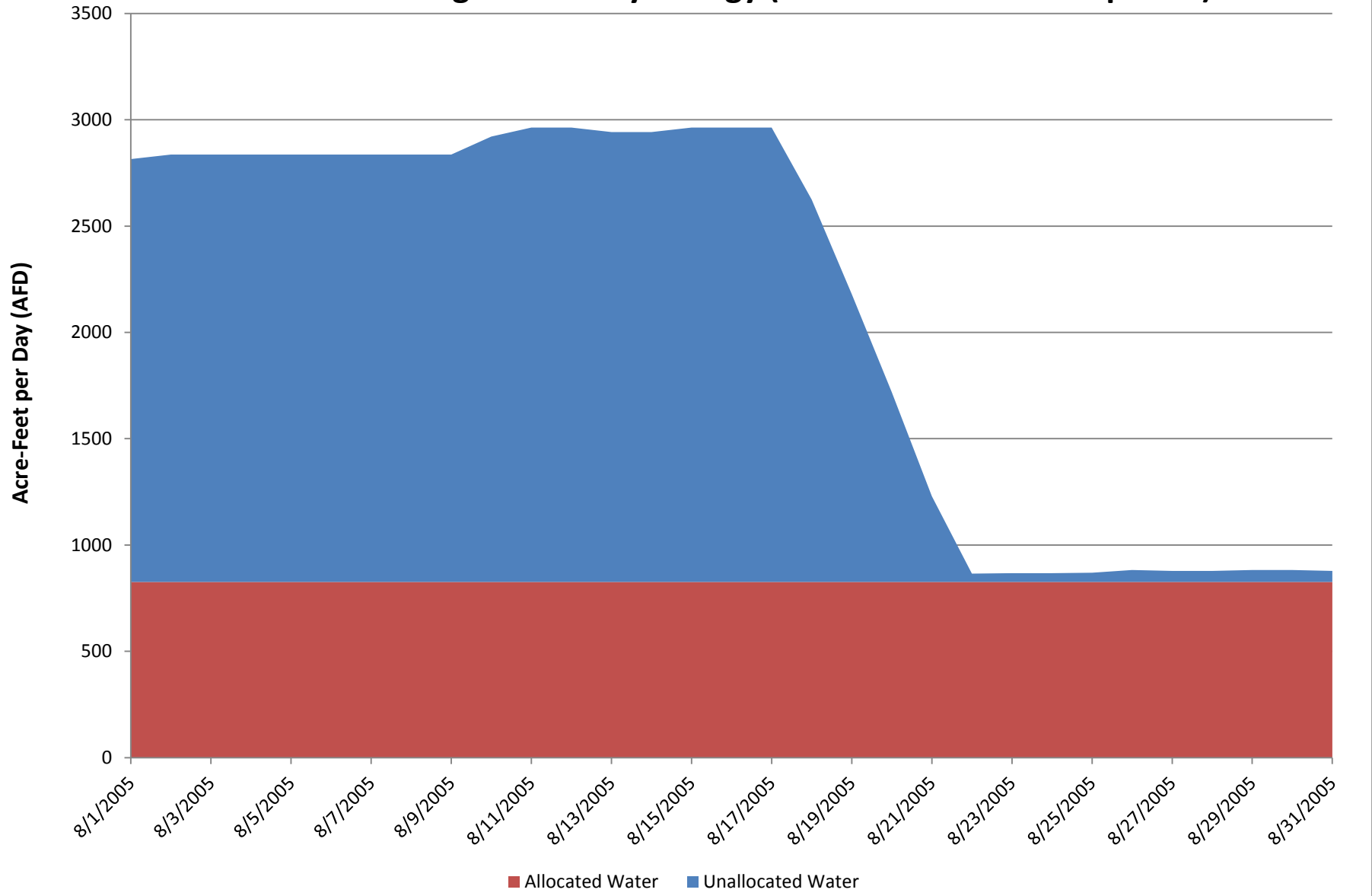
**Figure H-28: Daily Unallocated Water Calculation Downstream of Camanche Reservoir - June 2005 hydrology (2010 diversion assumptions)**



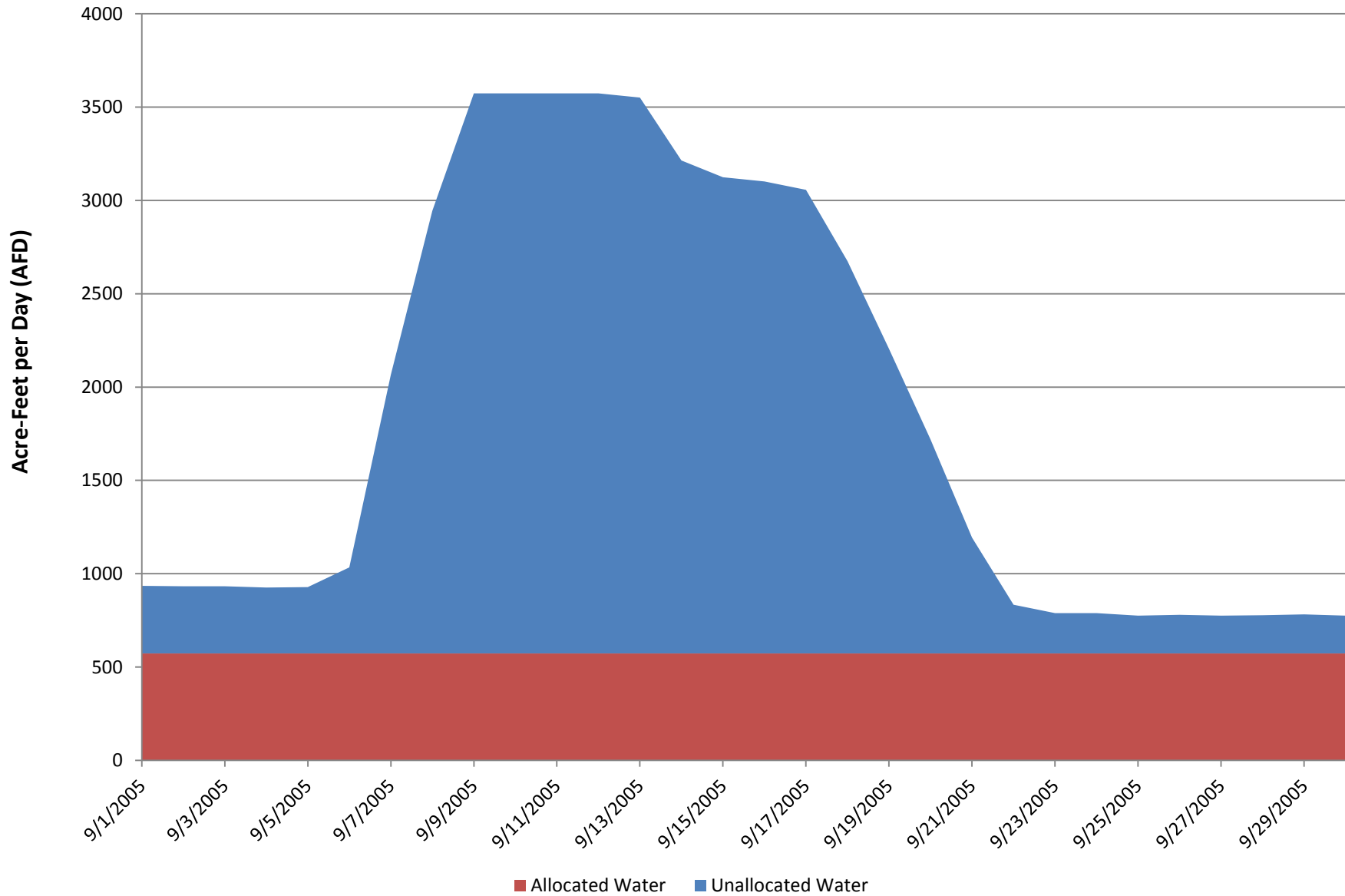
**Figure H-29: Daily Unallocated Water Calculation Downstream of Camanche Reservoir - July 2005 hydrology (2010 diversion assumptions)**



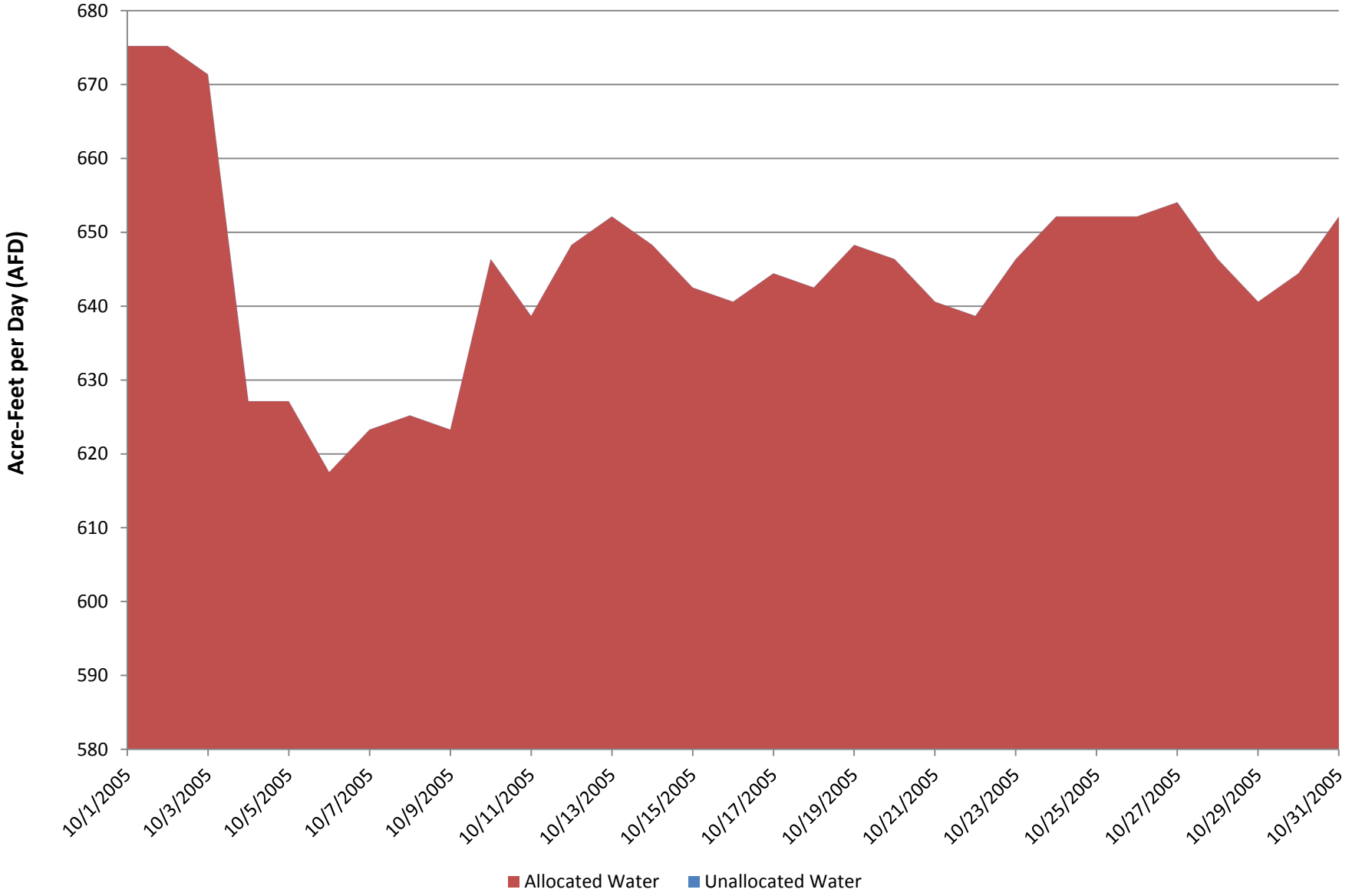
**Figure H-30: Daily Unallocated Water Calculation Downstream of Camanche Reservoir - August 2005 hydrology (2010 diversion assumptions)**



**Figure H-31: Daily Unallocated Water Calculation Downstream of Camanche Reservoir - September 2005 hydrology (2010 diversion assumptions)**

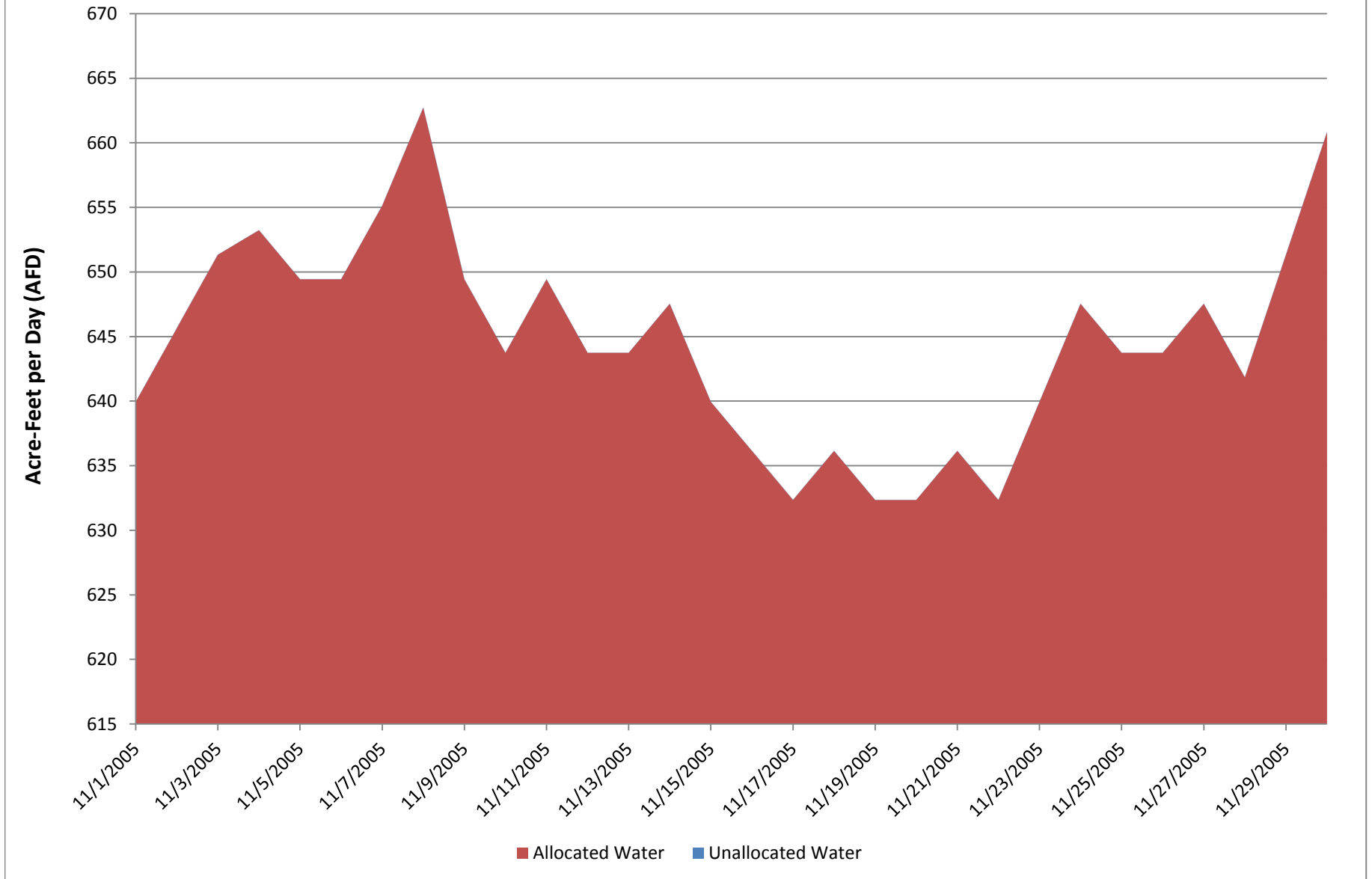


**Figure H-32: Daily Unallocated Water Calculation Downstream of Camanche Reservoir - October 2005 hydrology (2010 diversion assumptions)**

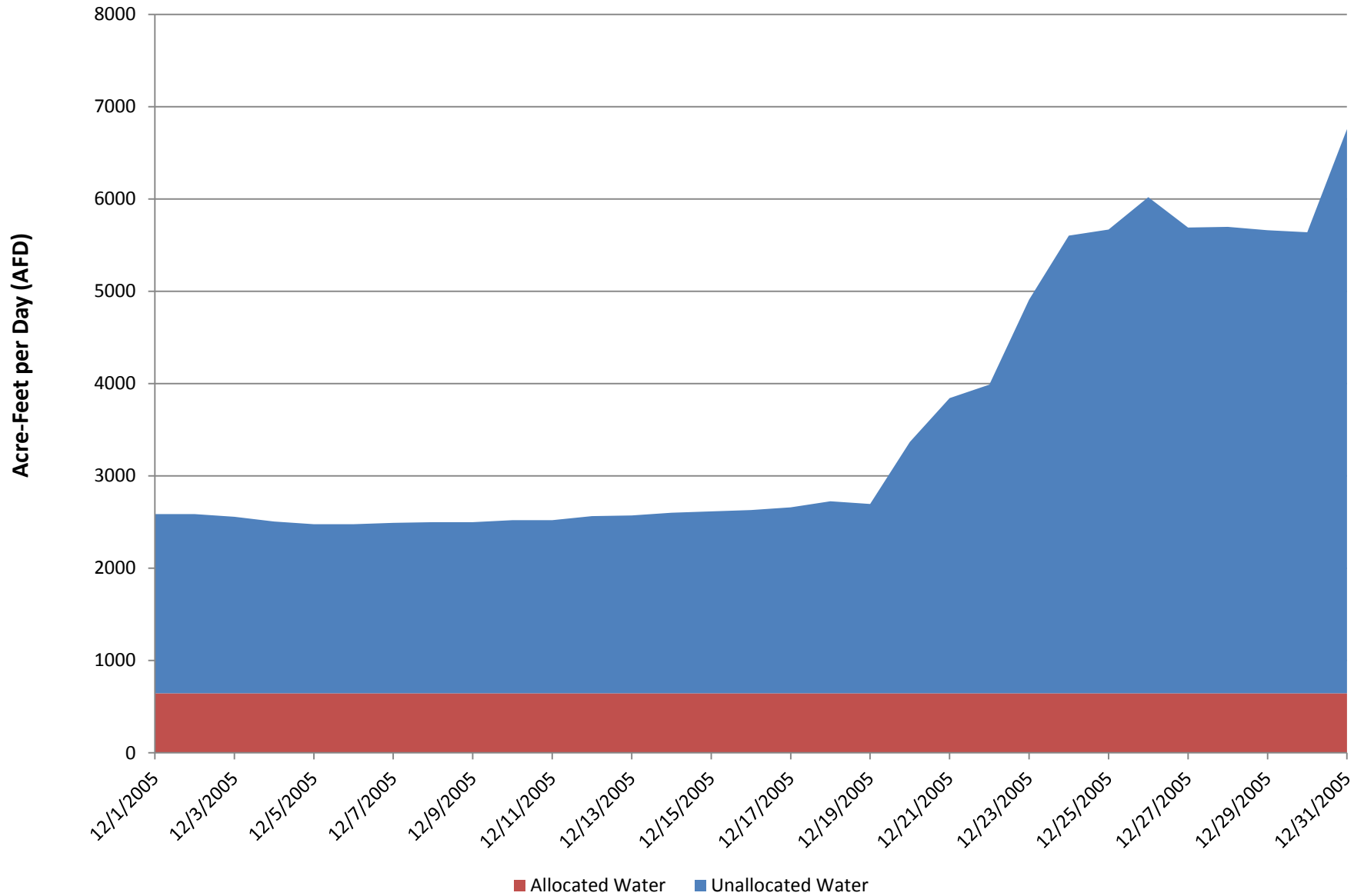




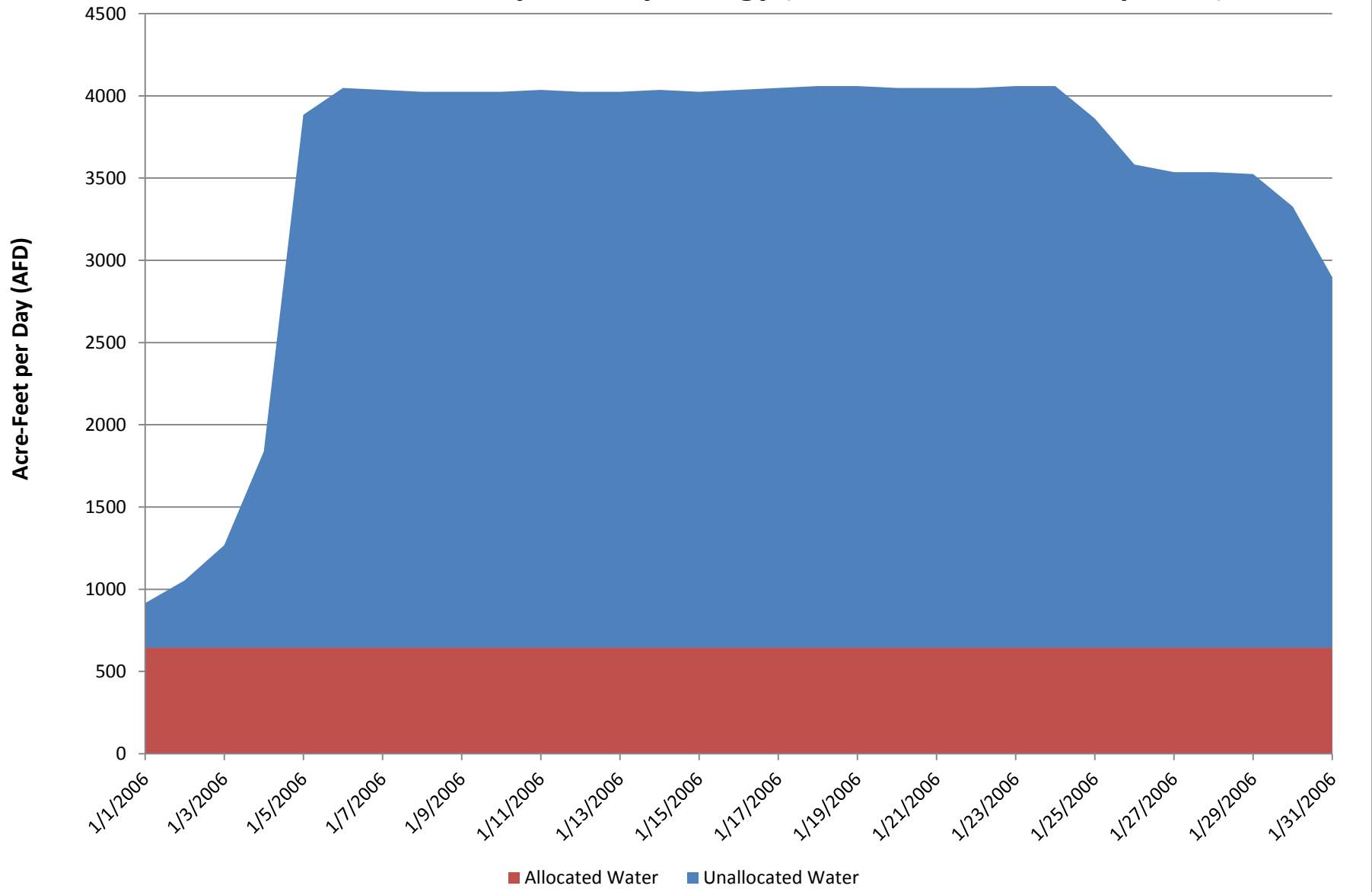
**Figure H-33: Daily Unallocated Water Calculation Downstream of Camanche Reservoir - November 2005 hydrology (2010 diversion assumptions)**



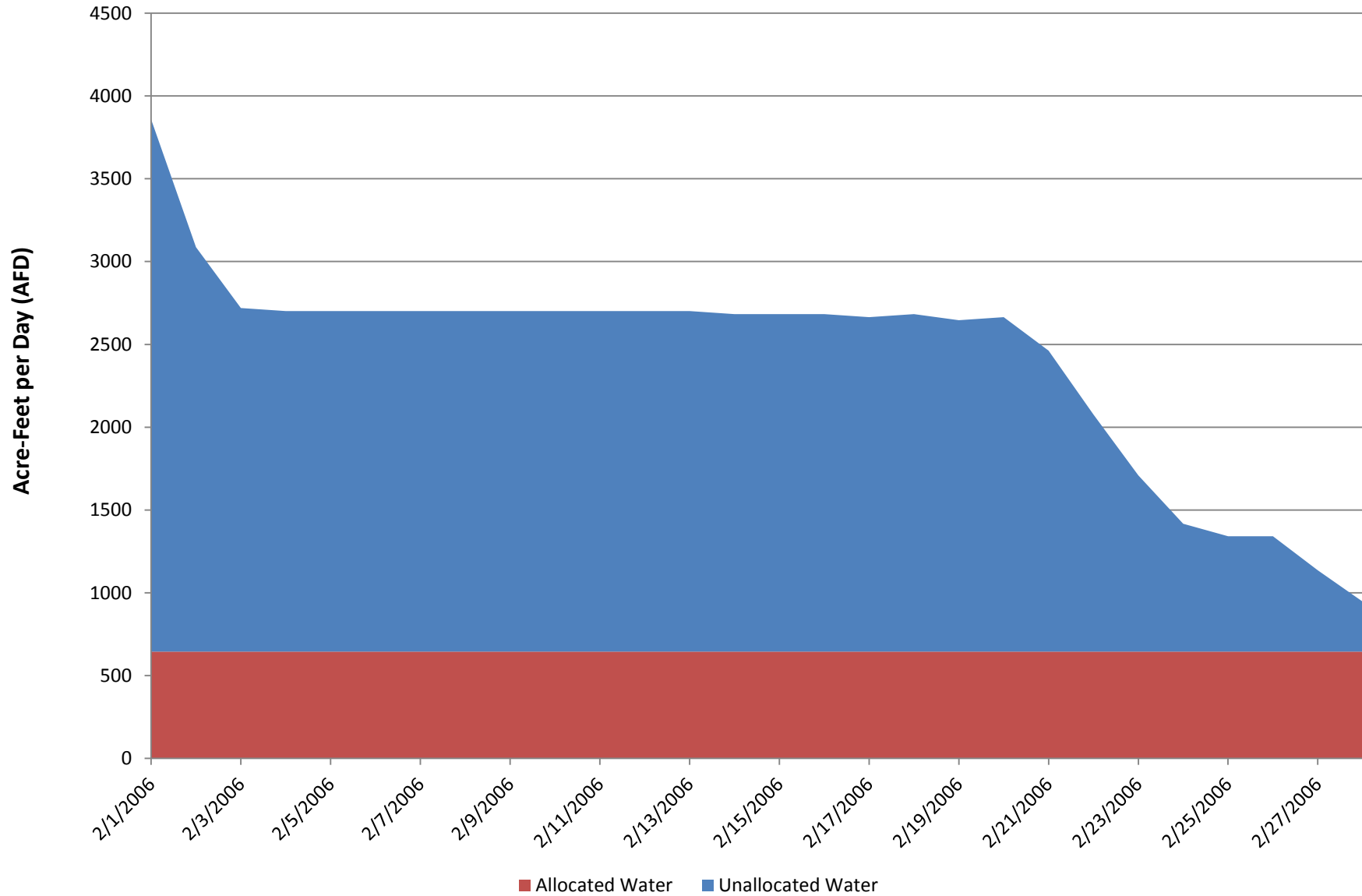
**Figure H-34: Daily Unallocated Water Calculation Downstream of Camanche Reservoir - December 2005 hydrology (2010 diversion assumptions)**



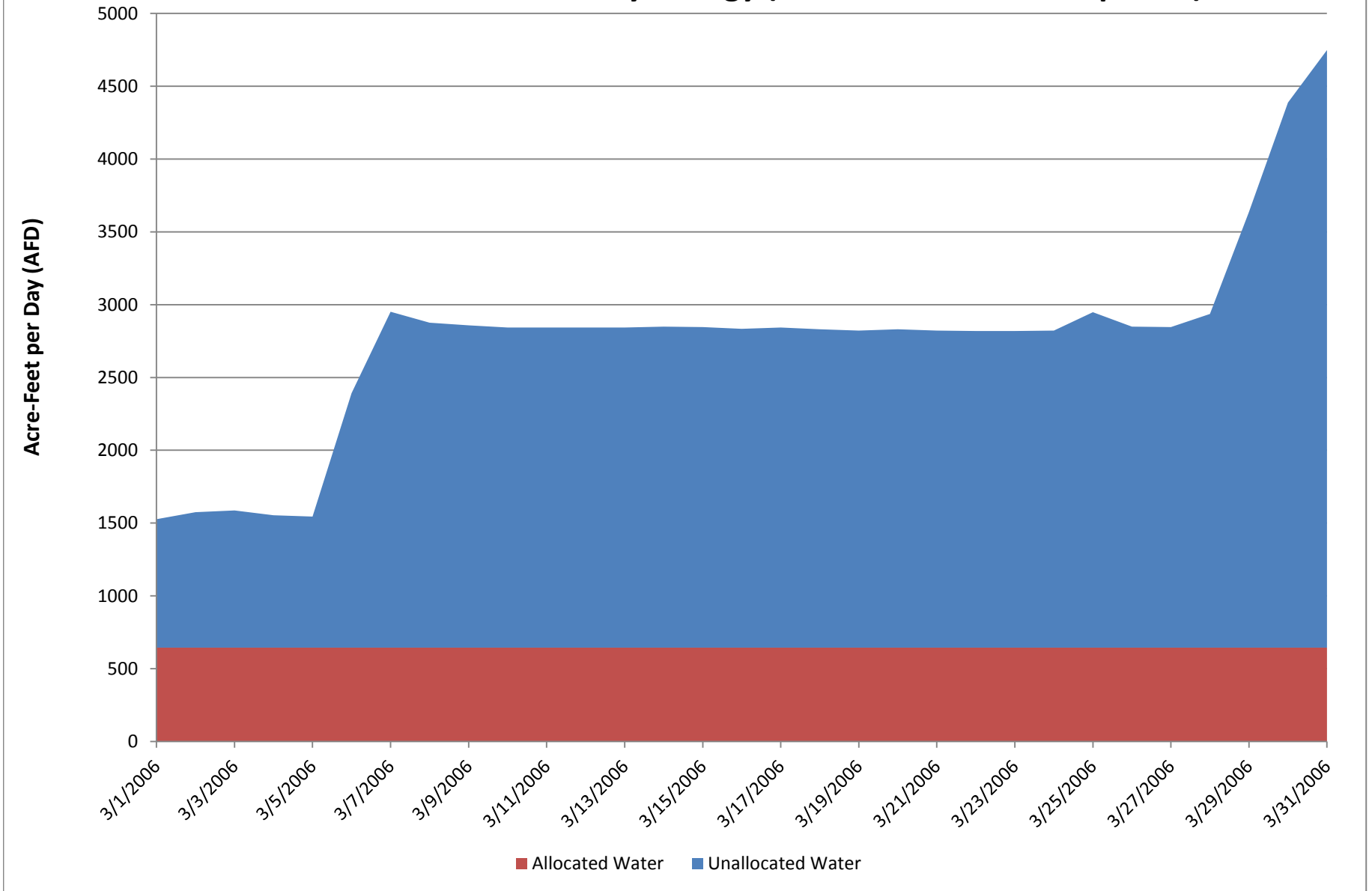
**Figure H-35: Daily Unallocated Water Calculation Downstream of Camanche Reservoir - January 2006 hydrology (2010 diversion assumptions)**



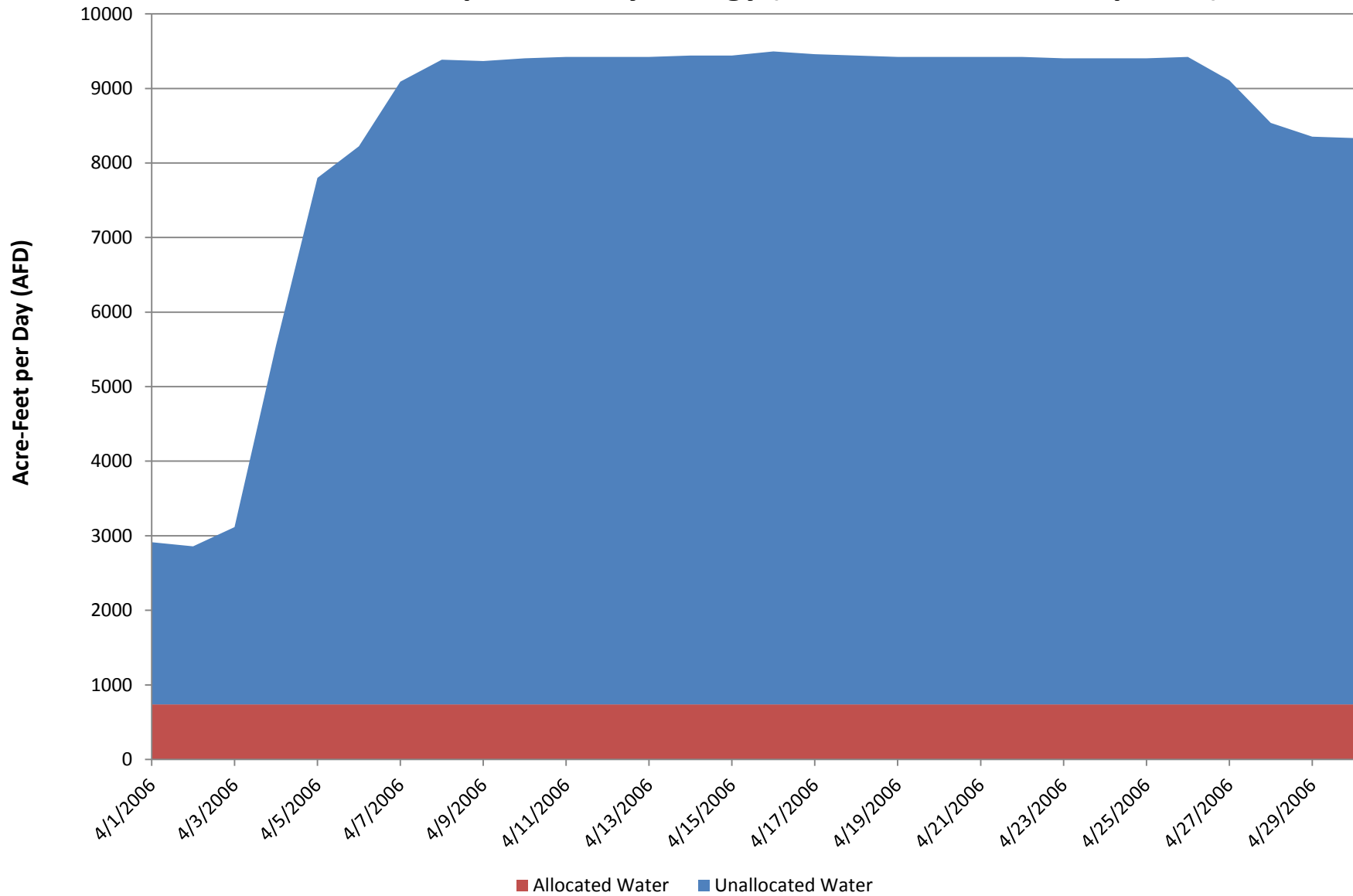
**Figure H-36: Daily Unallocated Water Calculation Downstream of Camanche Reservoir - February 2006 hydrology (2010 diversion assumptions)**



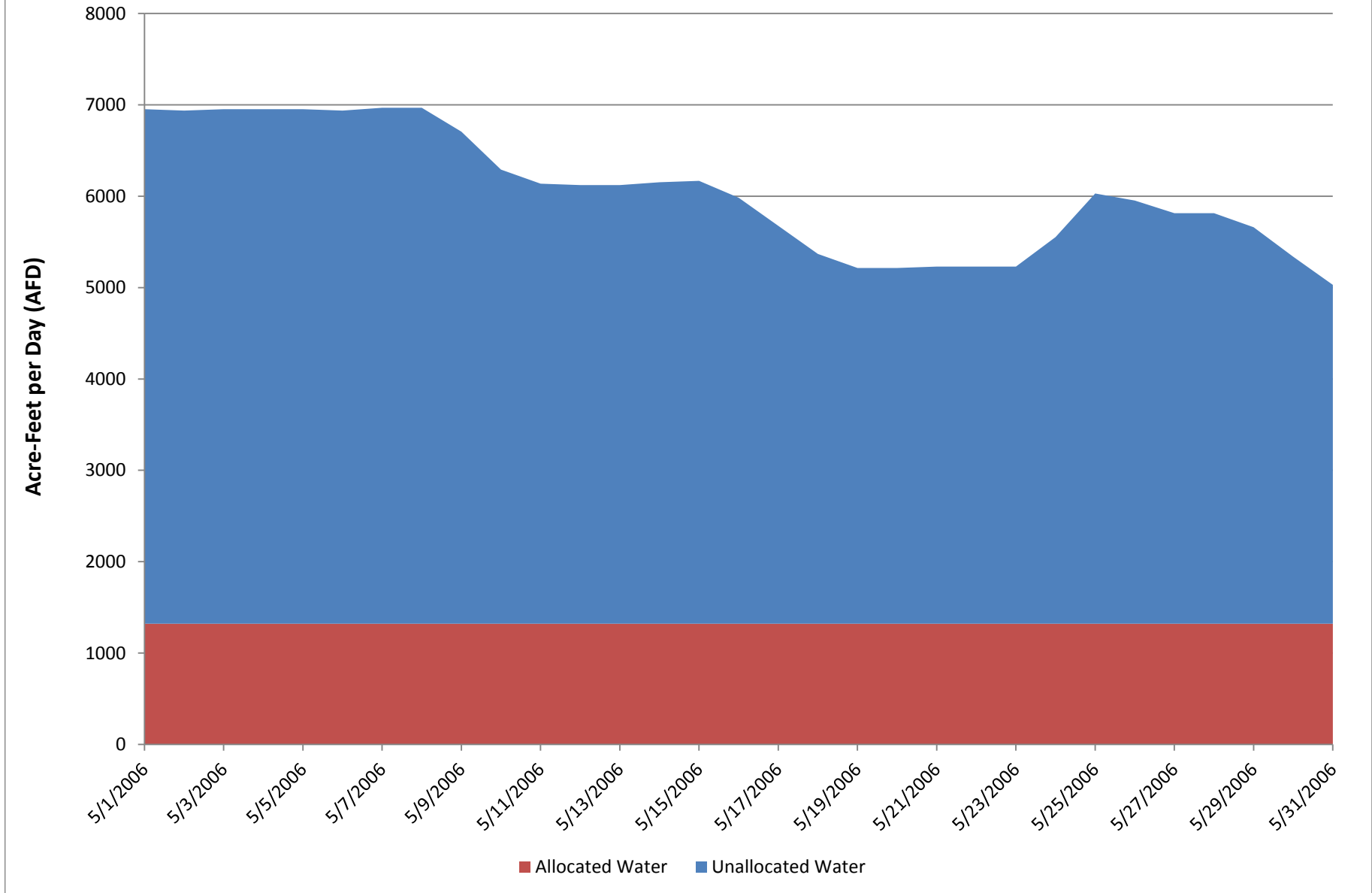
**Figure H-37: Daily Unallocated Water Calculation Downstream of Camanche Reservoir - March 2006 hydrology (2010 diversion assumptions)**



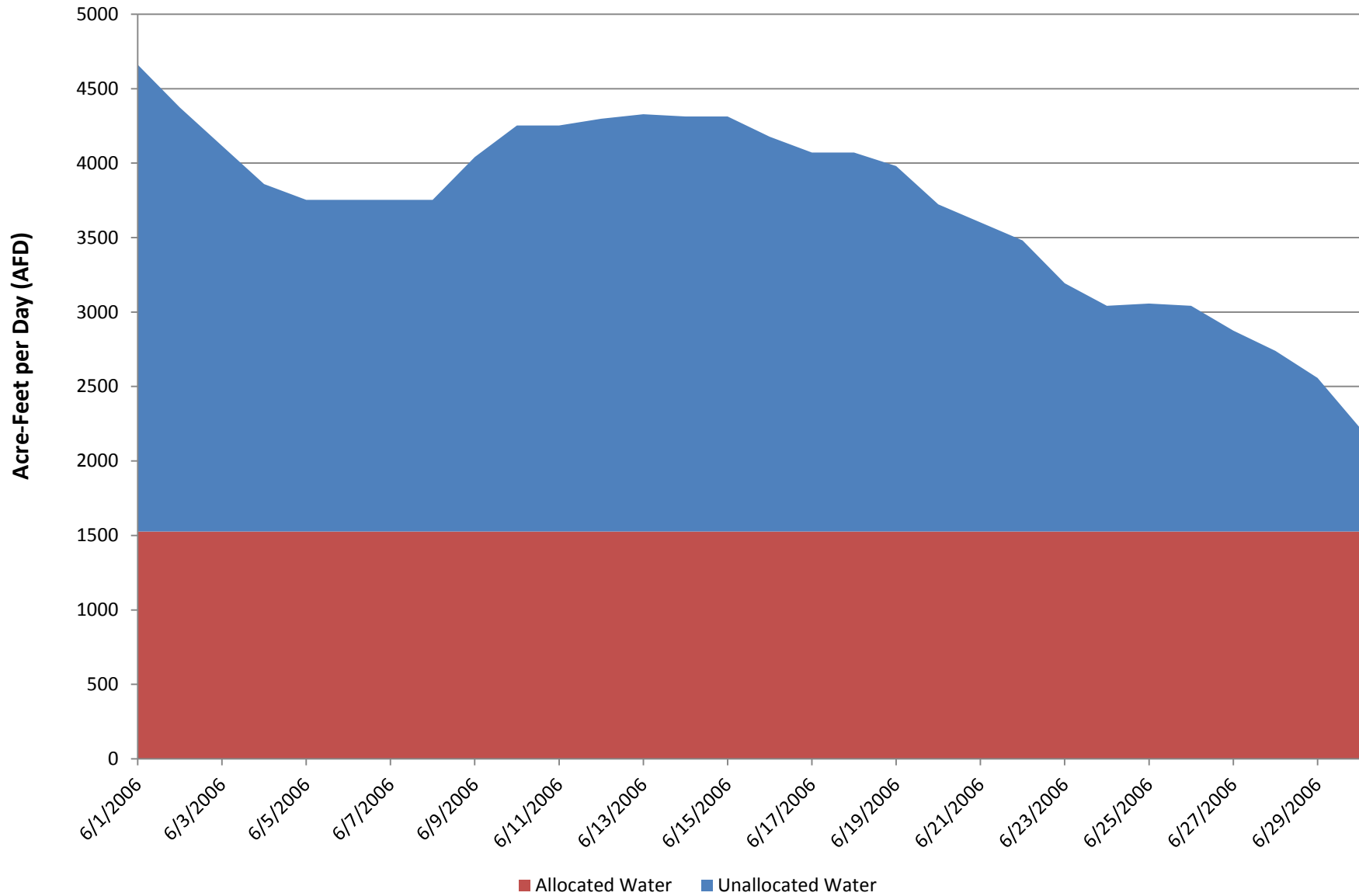
**Figure H-38: Daily Unallocated Water Calculation Downstream of Camanche Reservoir - April 2006 hydrology (2010 diversion assumptions)**



**Figure H-39: Daily Unallocated Water Calculation Downstream of Camanche Reservoir - May 2006 hydrology (2010 diversion assumptions)**

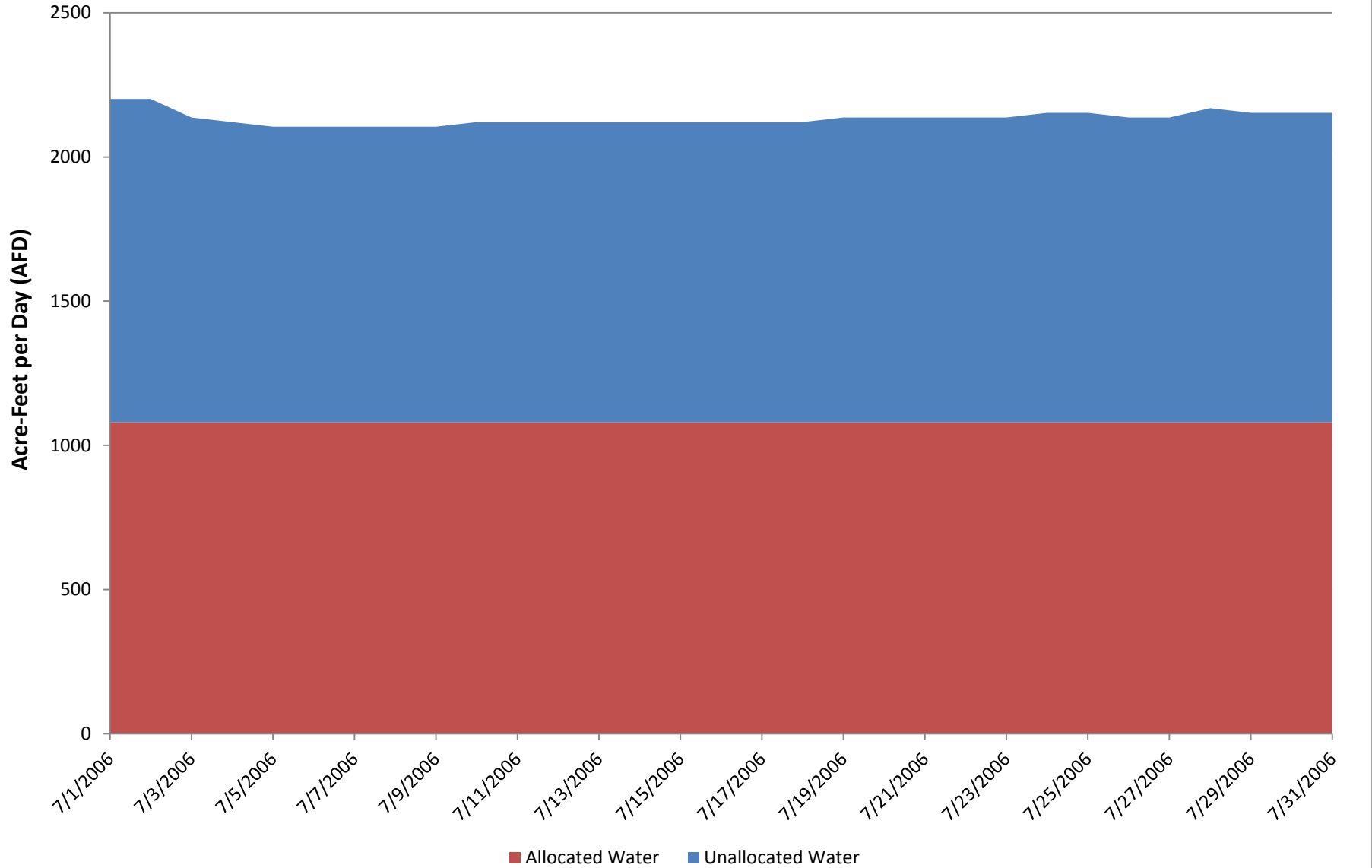


**Figure H-40: Daily Unallocated Water Calculation Downstream of Camanche Reservoir - June 2006 hydrology (2010 diversion assumptions)**

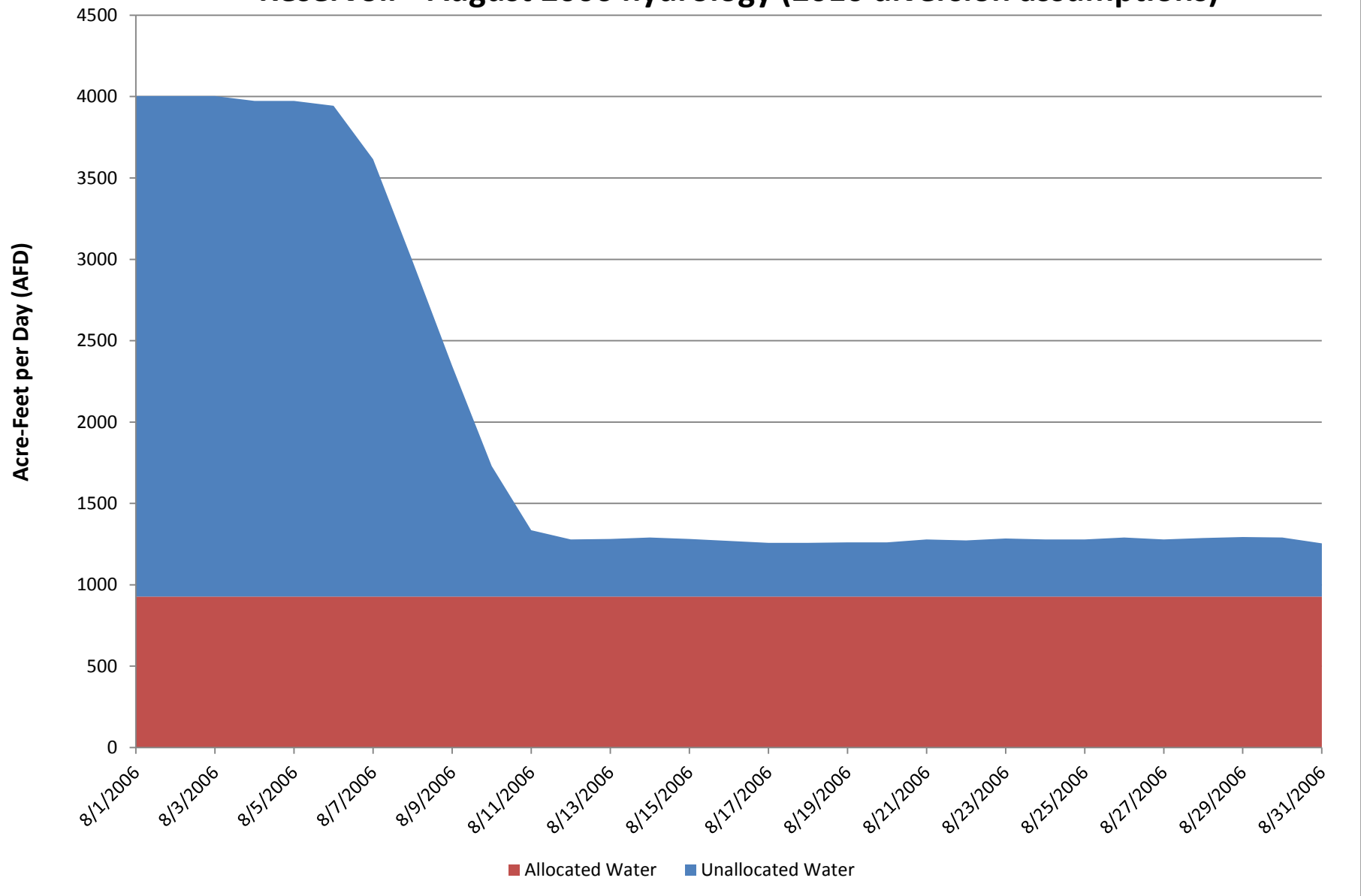




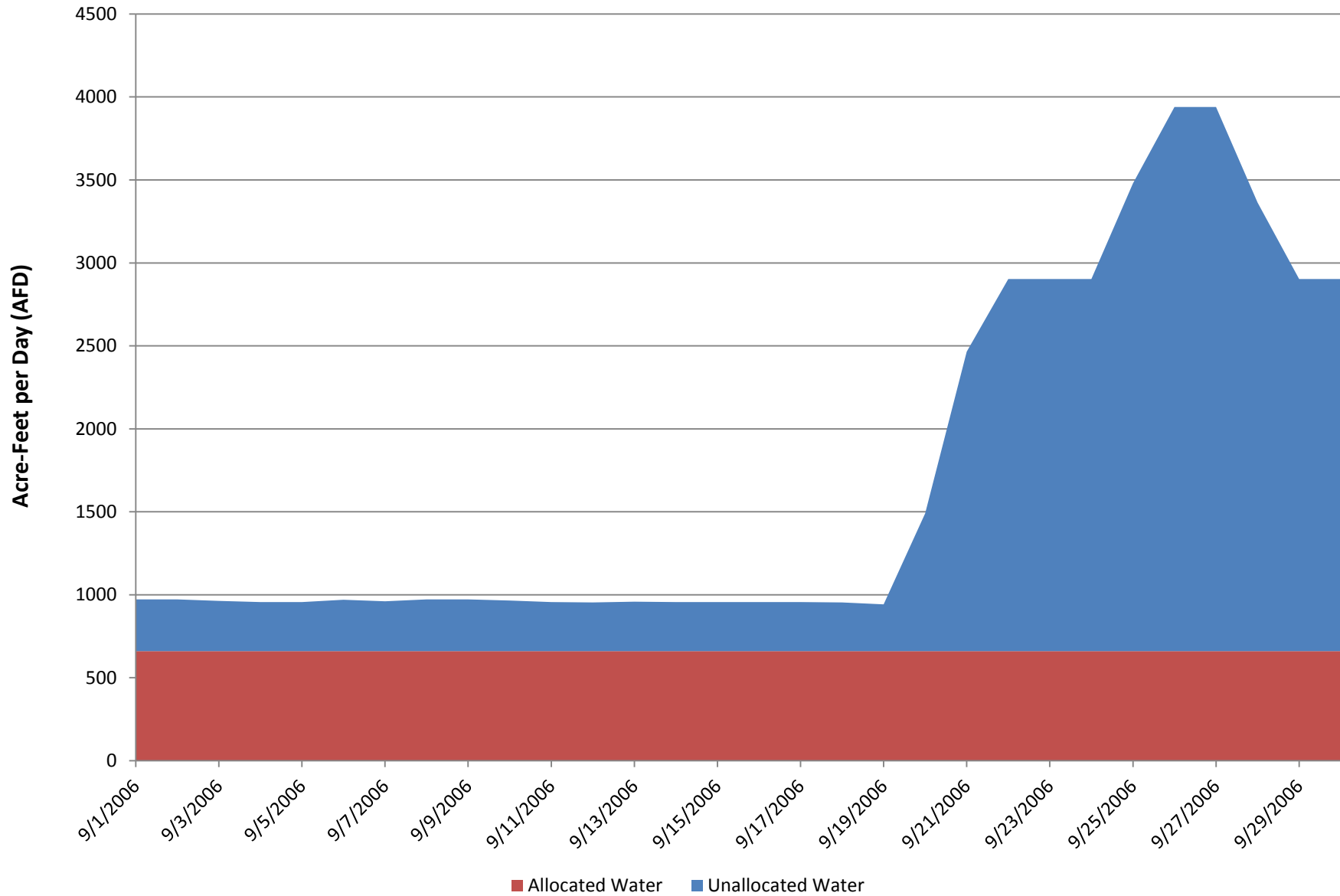
**Figure H-41: Daily Unallocated Water Calculation Downstream of Camanche Reservoir - July 2006 hydrology (2010 diversion assumptions)**



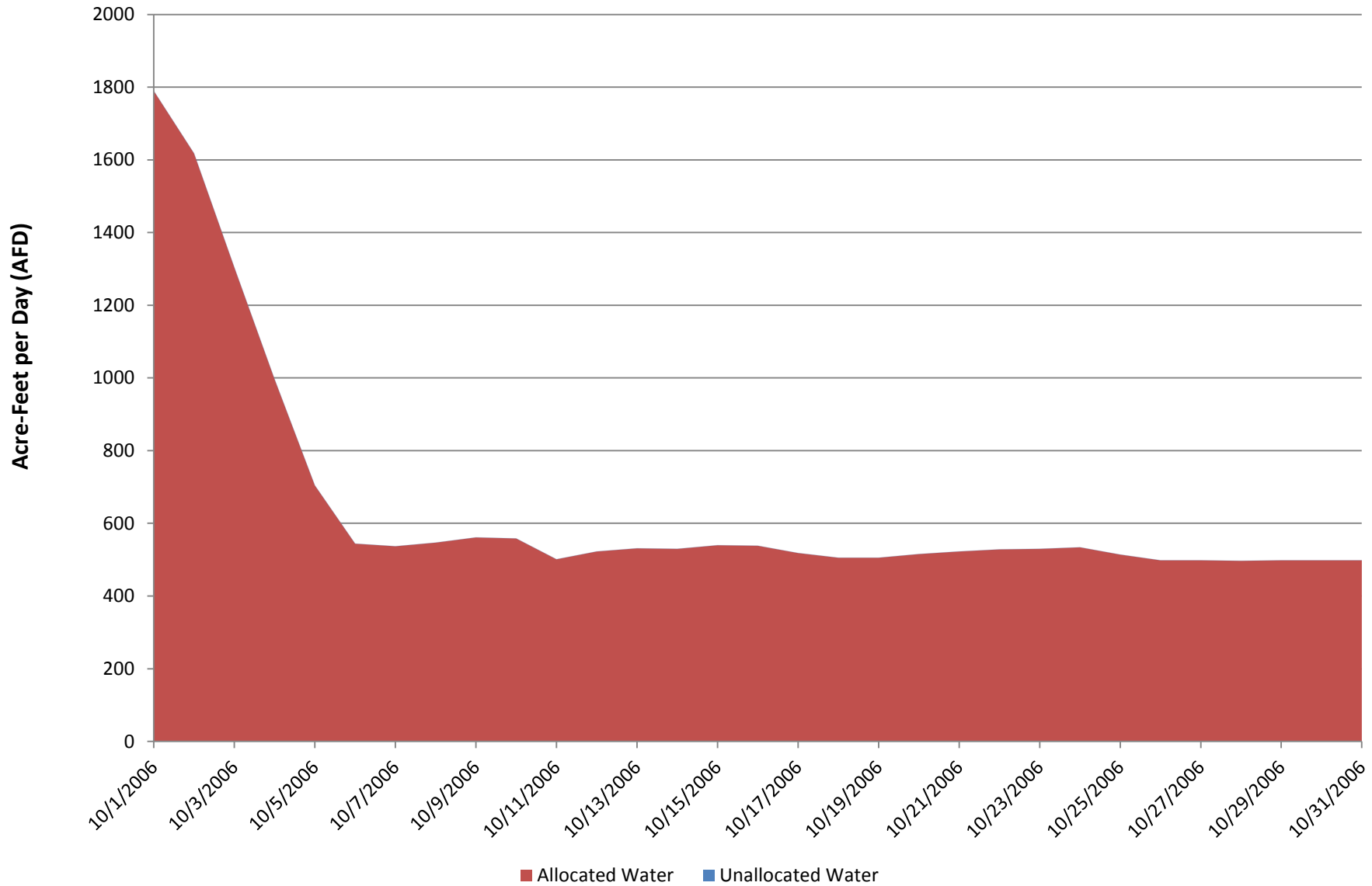
**Figure H-42: Daily Unallocated Water Calculation Downstream of Camanche Reservoir - August 2006 hydrology (2010 diversion assumptions)**



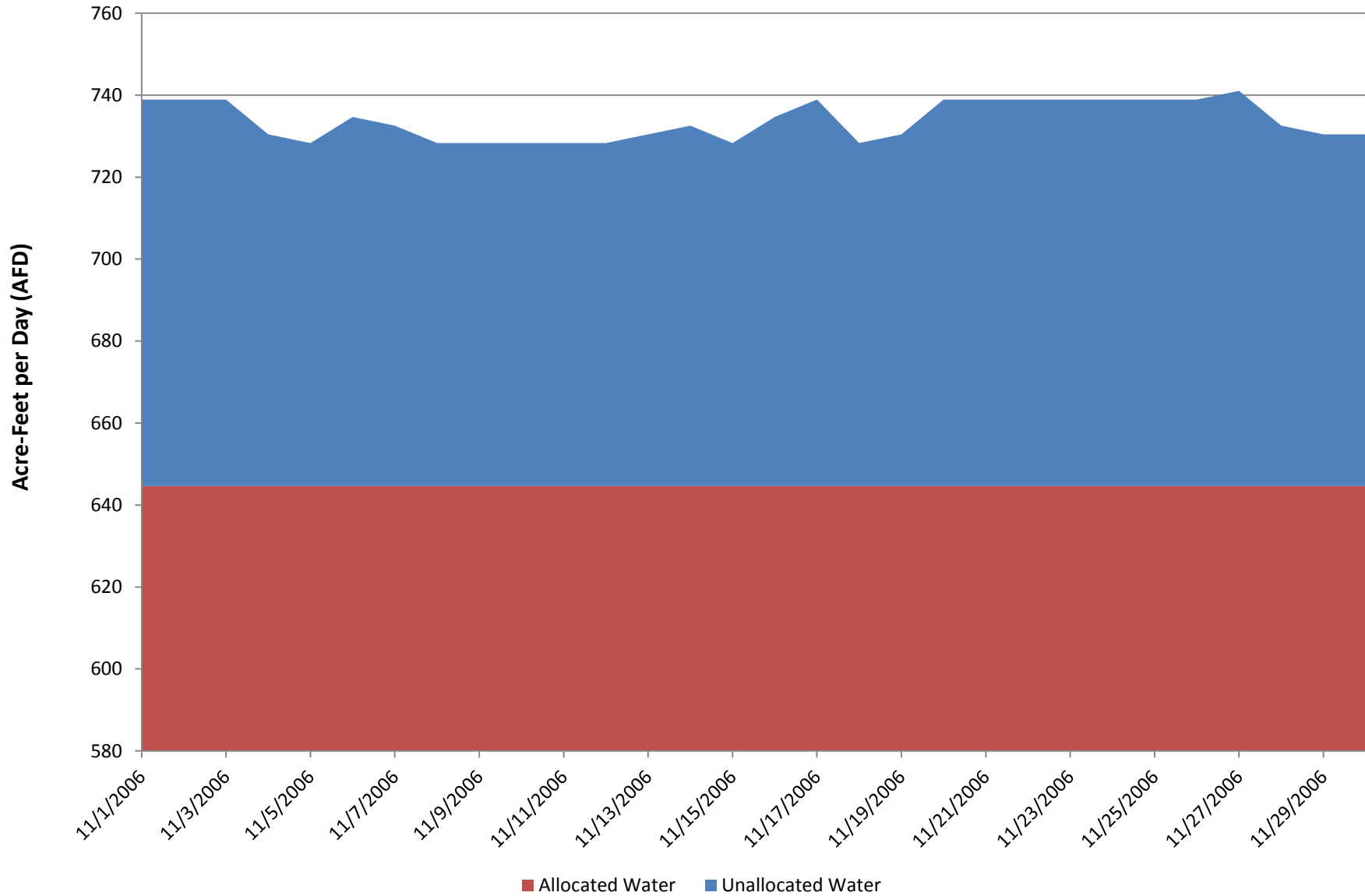
**Figure H-43: Daily Unallocated Water Calculation Downstream of Camanche Reservoir - September 2006 hydrology (2010 diversion assumptions)**



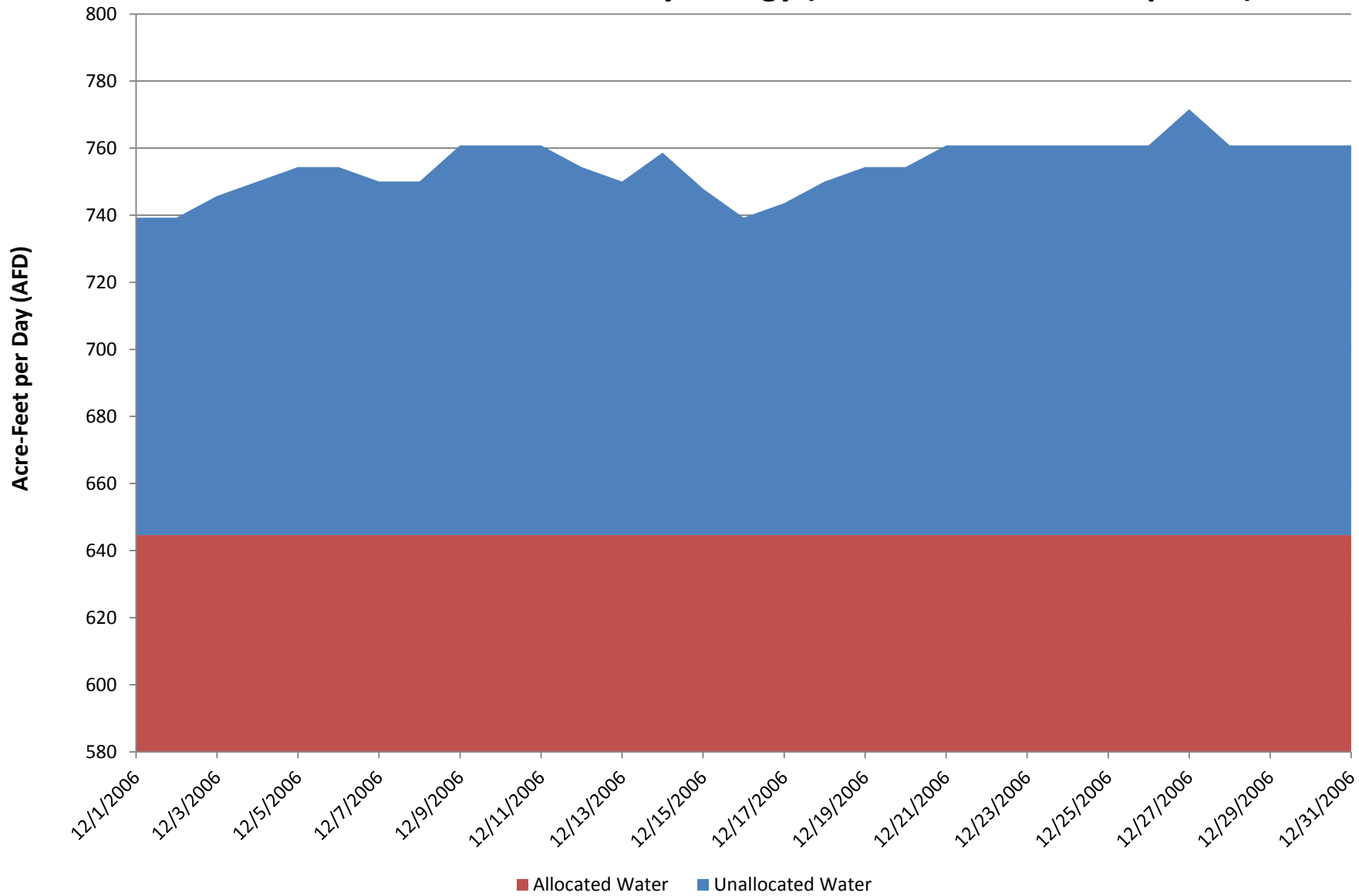
**Figure H-44: Daily Unallocated Water Calculation Downstream of Camanche Reservoir - October 2006 hydrology (2010 diversion assumptions)**



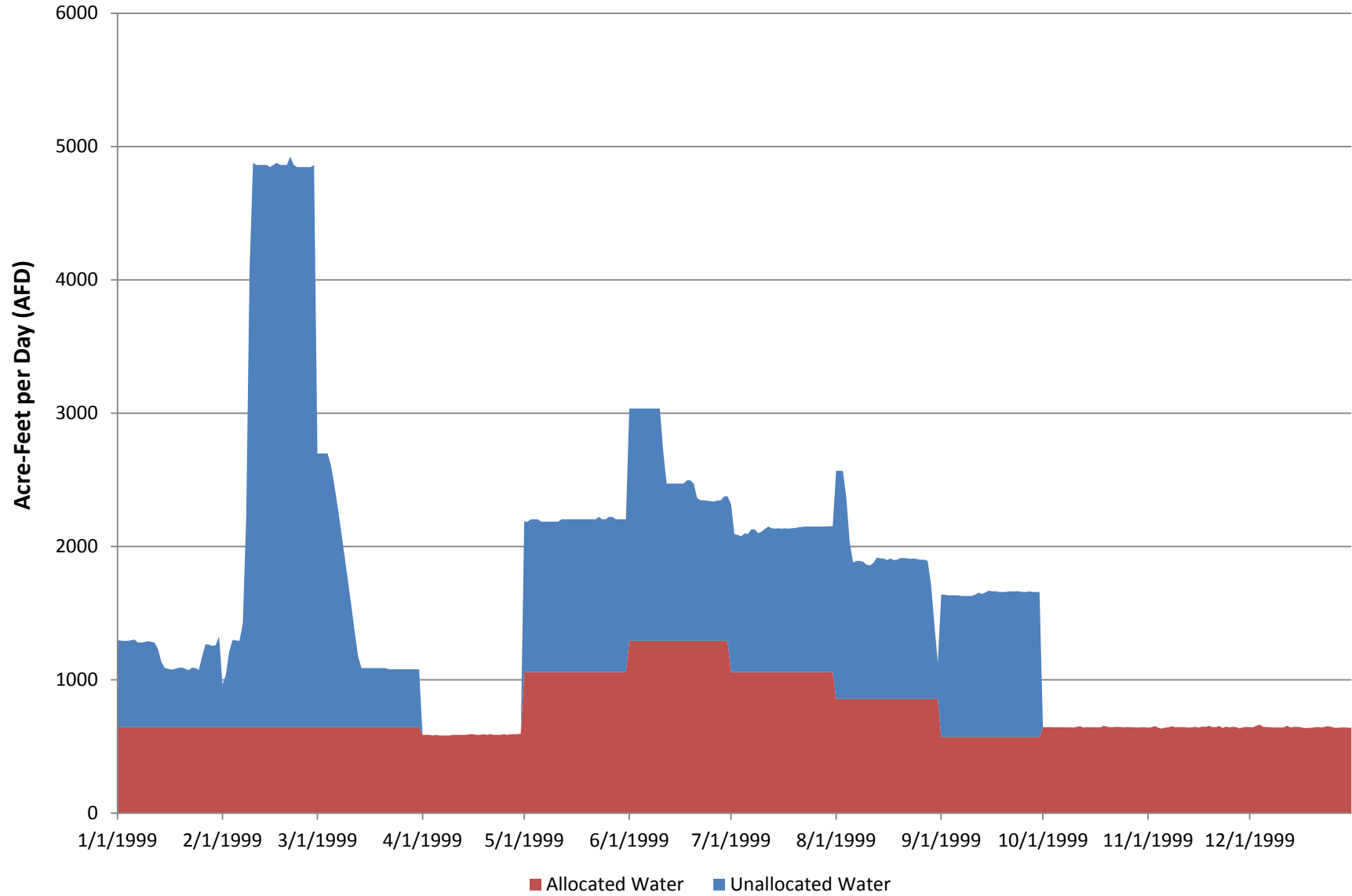
**Figure H-45: Daily Unallocated Water Calculation Downstream of Camanche Reservoir - November 2006 hydrology (2010 diversion assumptions)**



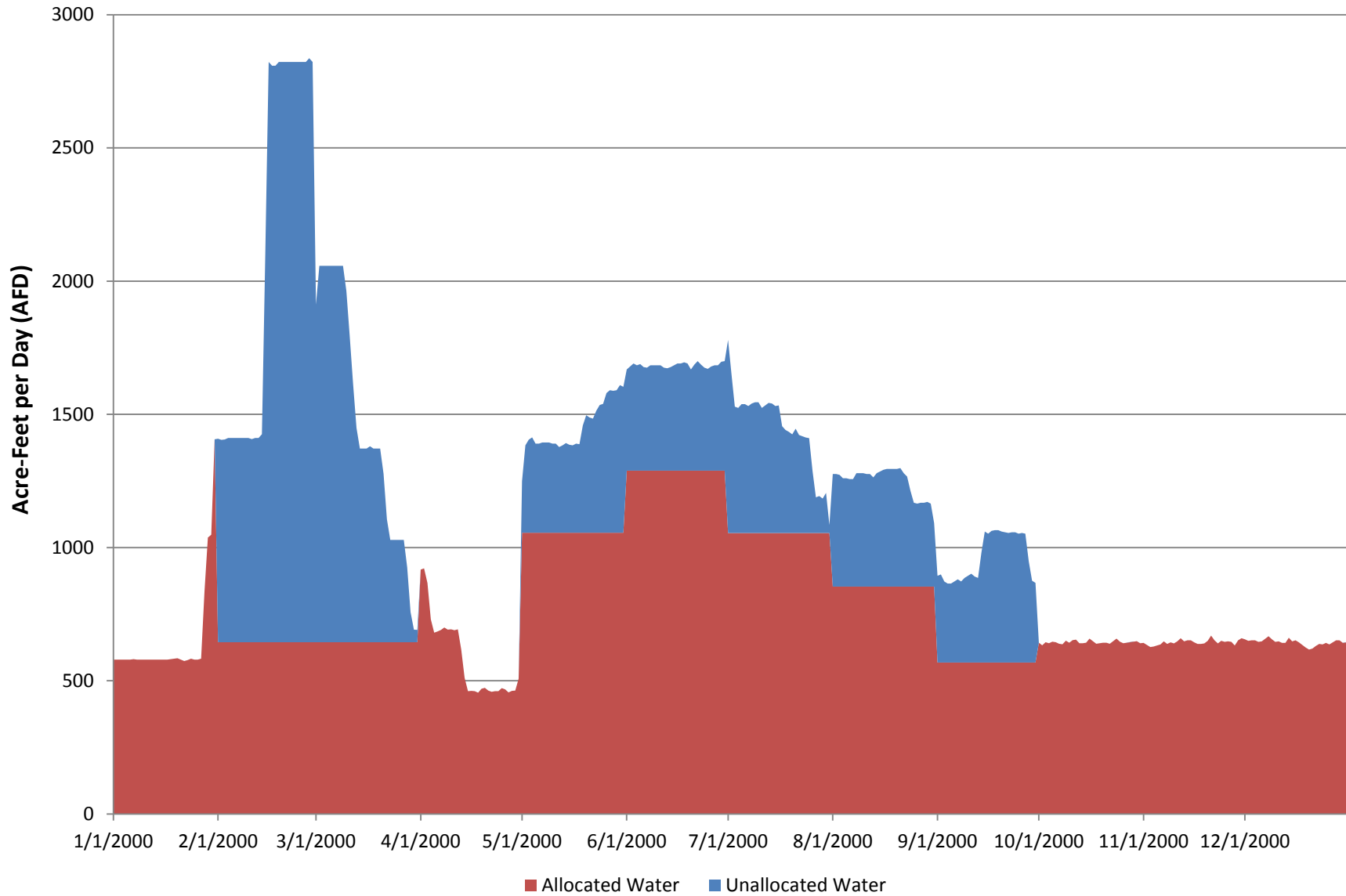
**Figure H-46: Daily Unallocated Water Calculation Downstream of Camanche Reservoir - December 2006 hydrology (2010 diversion assumptions)**



**Figure H-47: Daily Unallocated Water Calculation Downstream of Camanche Reservoir - 1999 hydrology (2040 diversion assumptions)**

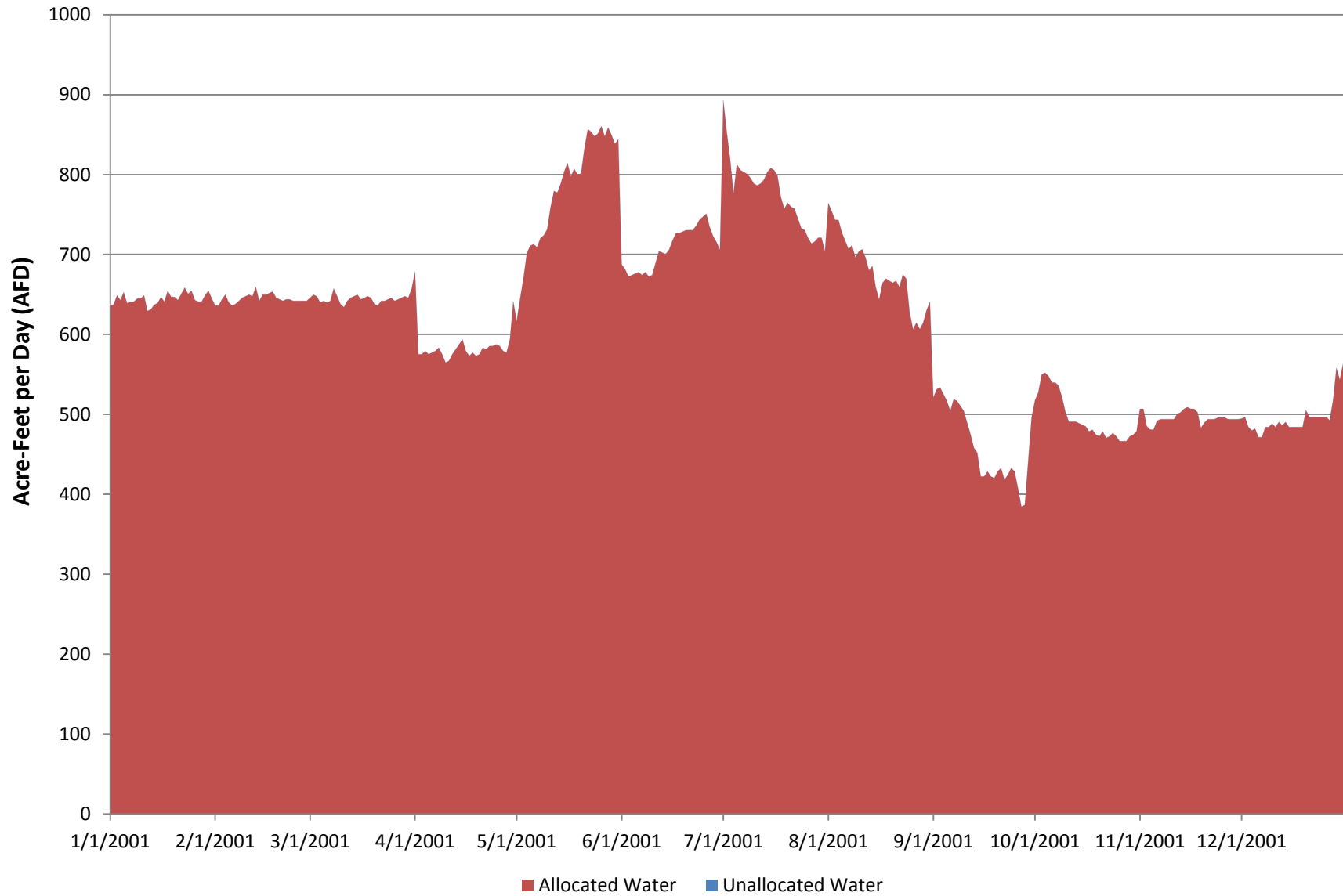


**Figure H-48: Daily Unallocated Water Calculation Downstream of Camanche Reservoir - 2000 hydrology (2040 diversion assumptions)**

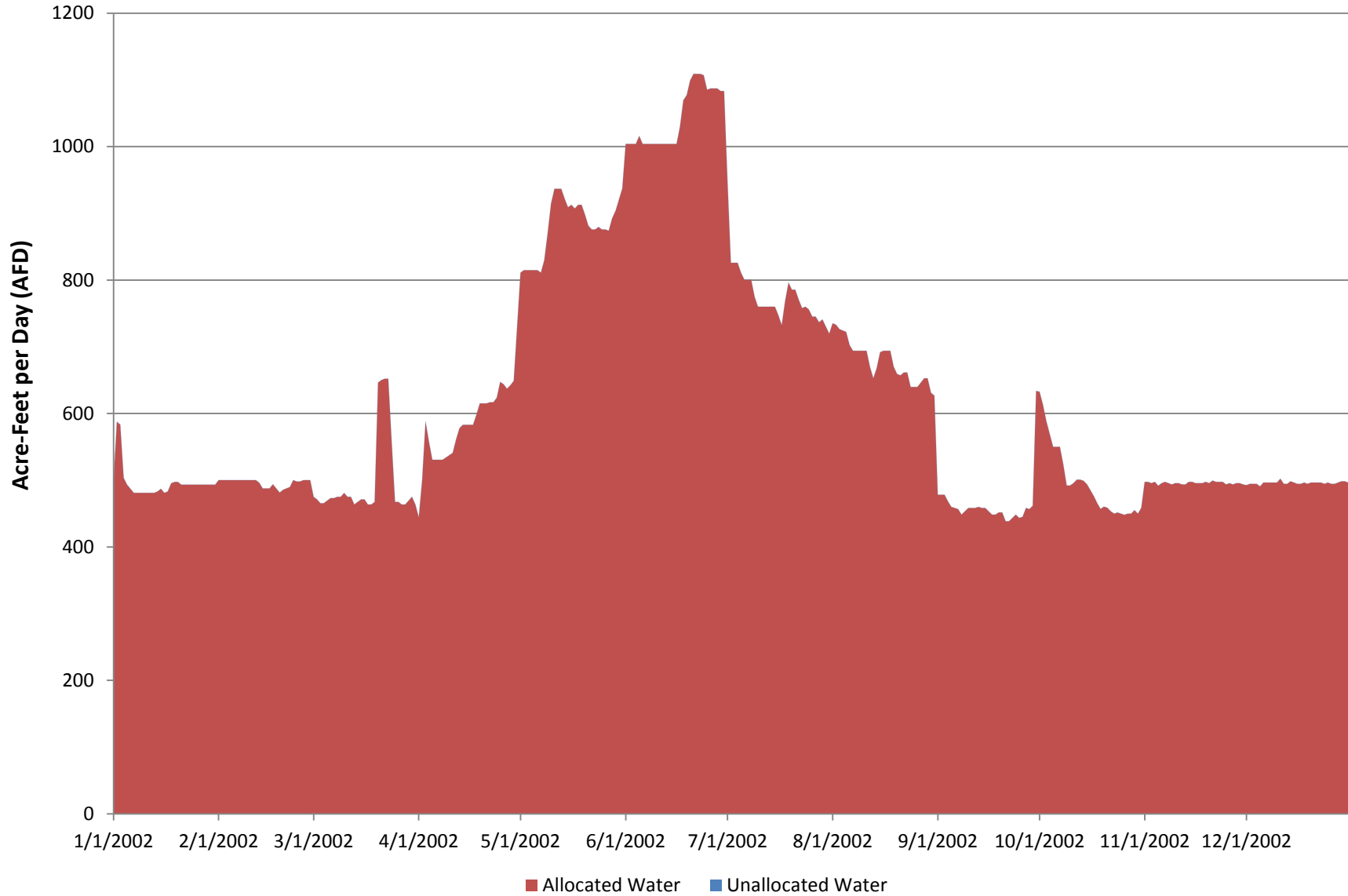




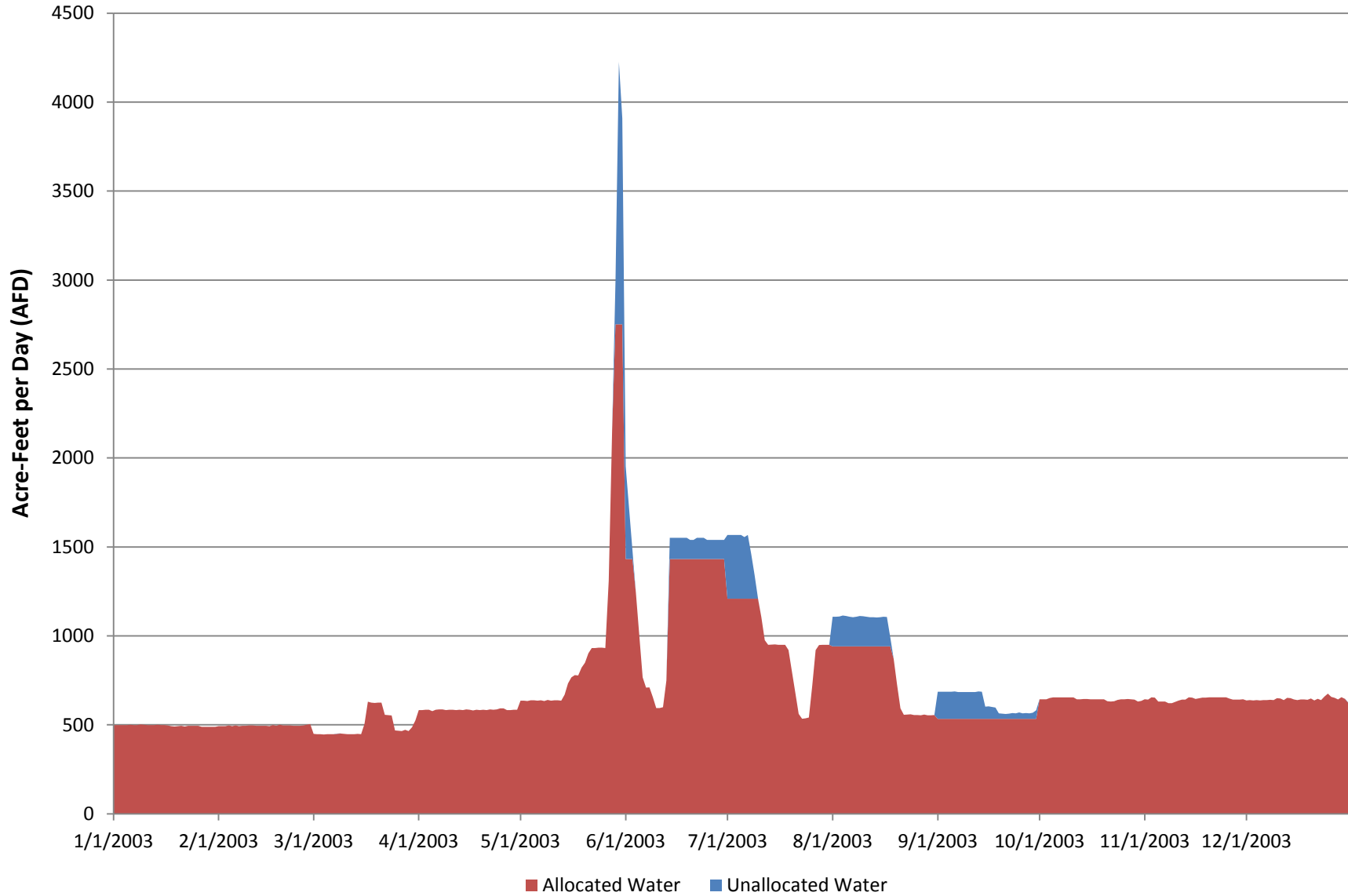
**Figure H-49: Daily Unallocated Water Calculation Downstream of Camanche Reservoir - 2001 hydrology (2040 diversion assumptions)**



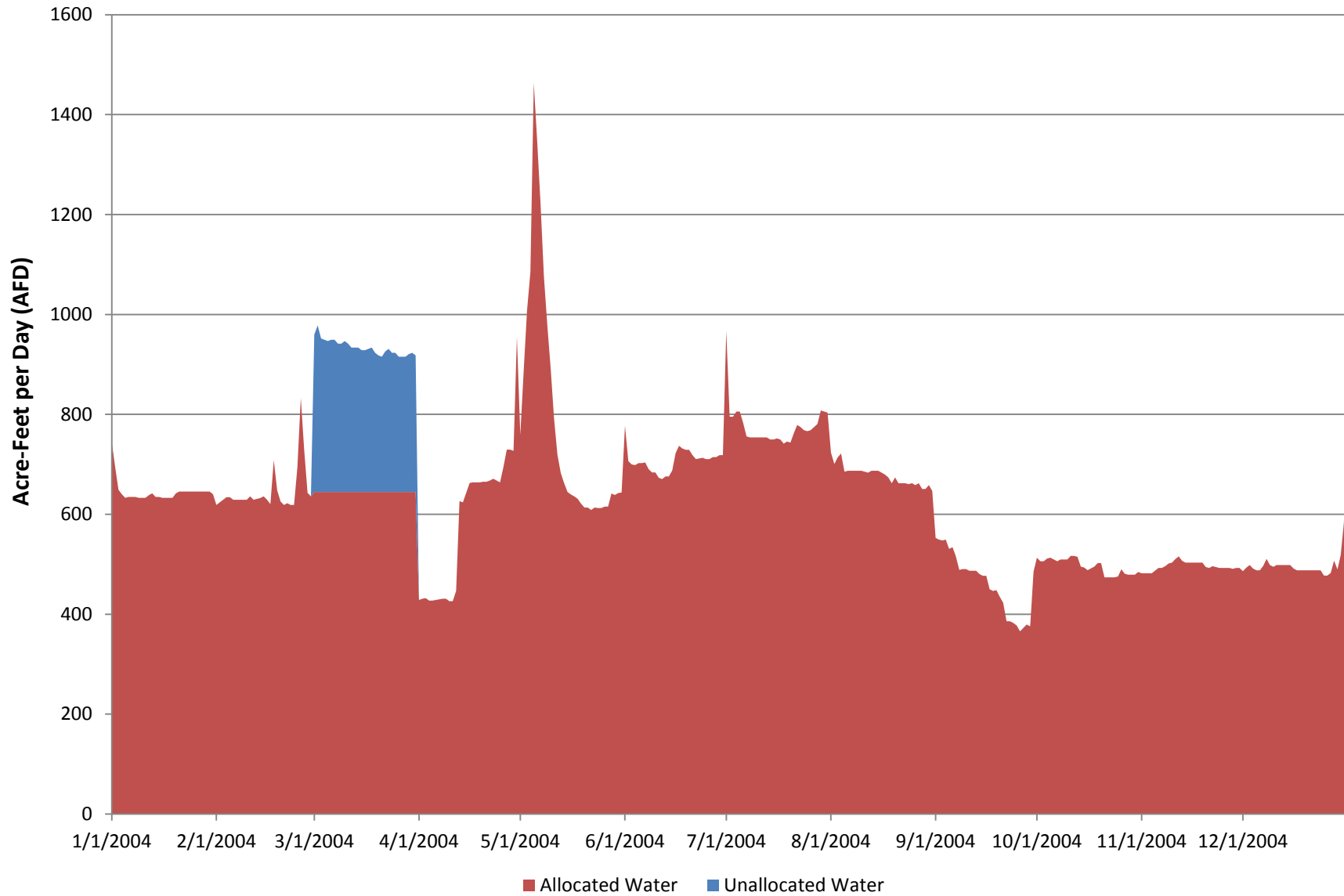
**Figure H-50: Daily Unallocated Water Calculation Downstream of Camanche Reservoir - 2002 hydrology (2040 diversion assumptions)**



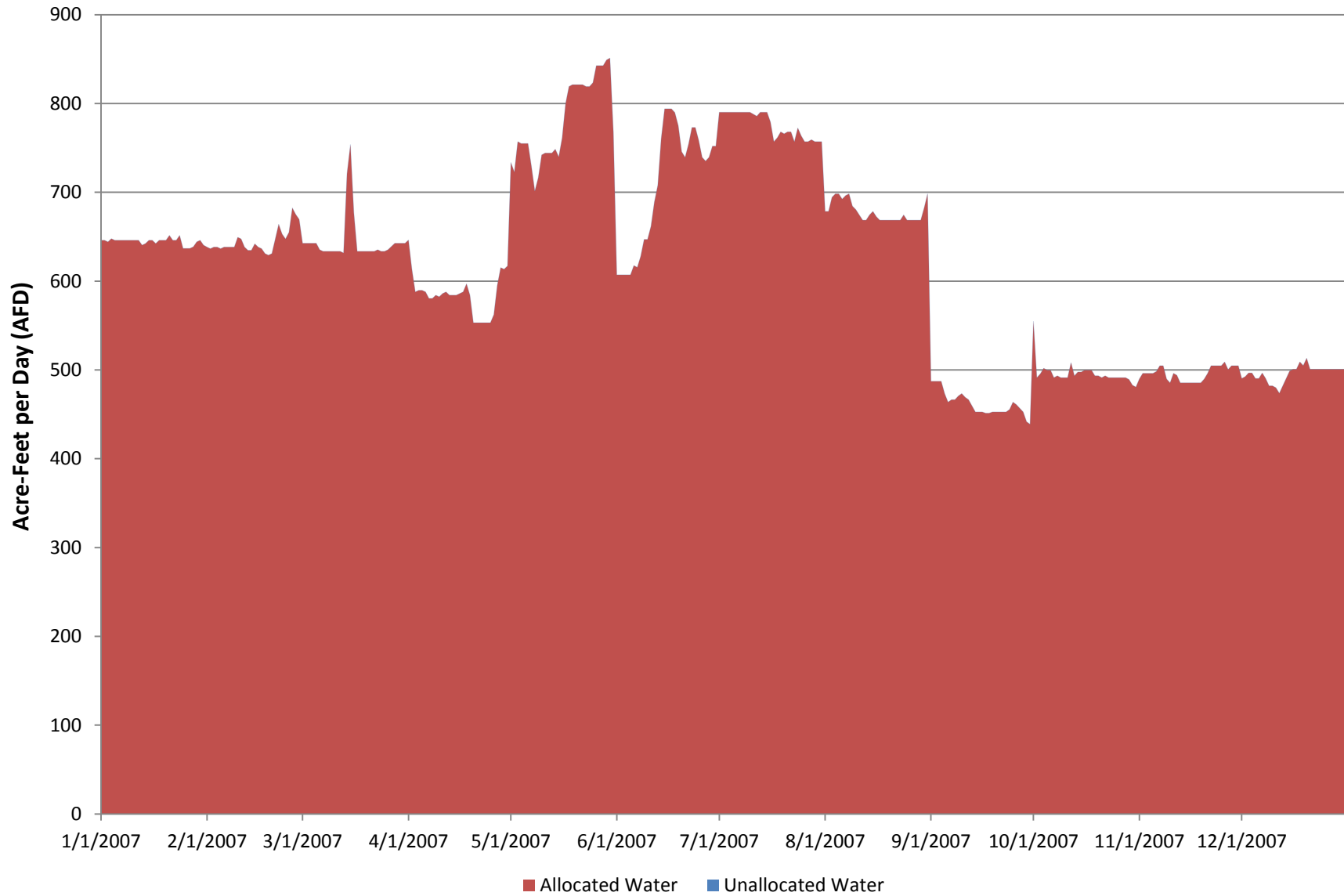
**Figure H-51: Daily Unallocated Water Calculation Downstream of Camanche Reservoir - 2003 hydrology (2040 diversion assumptions)**



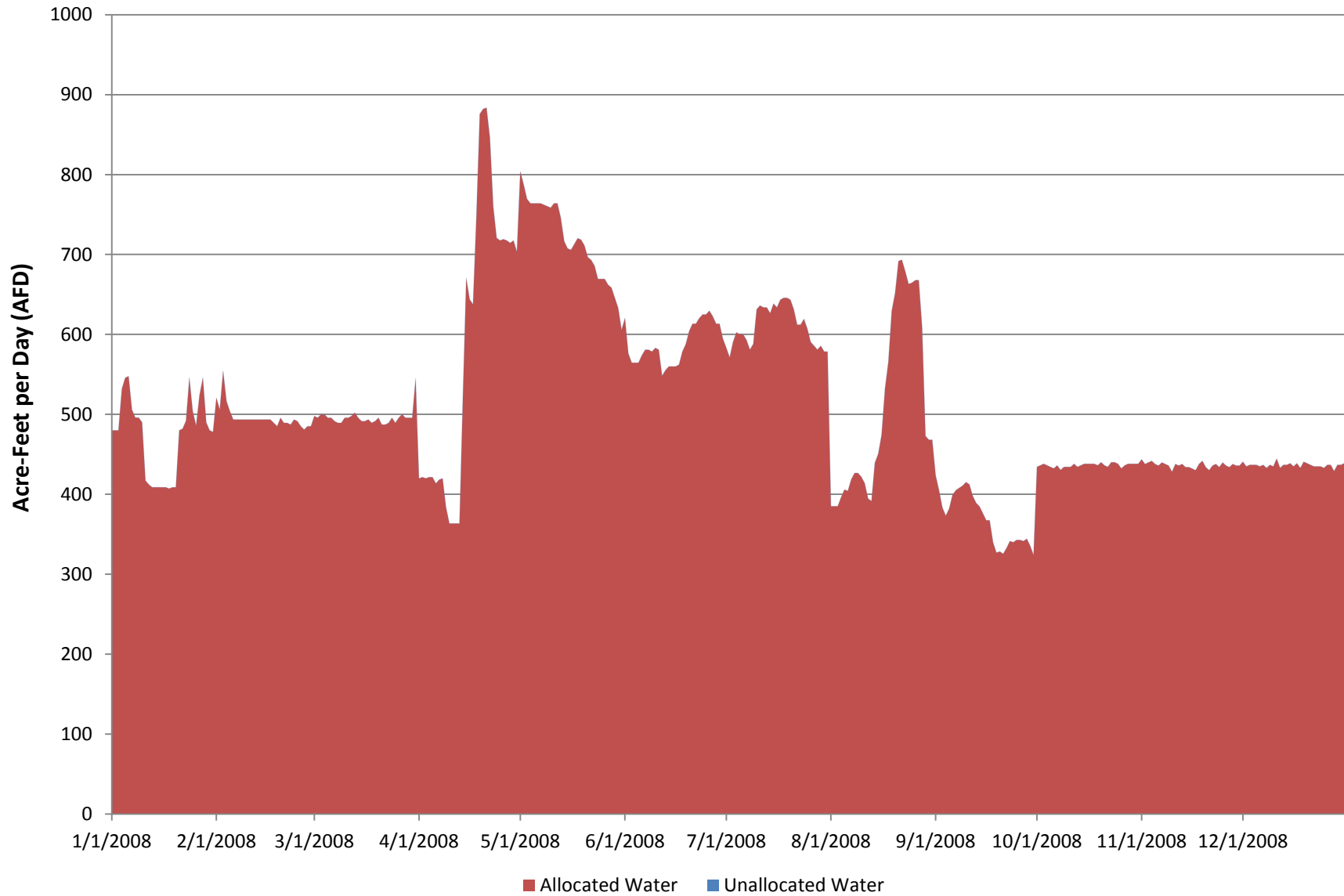
**Figure H-52: Daily Unallocated Water Calculation Downstream of Camanche Reservoir - 2004 hydrology (2040 diversion assumptions)**



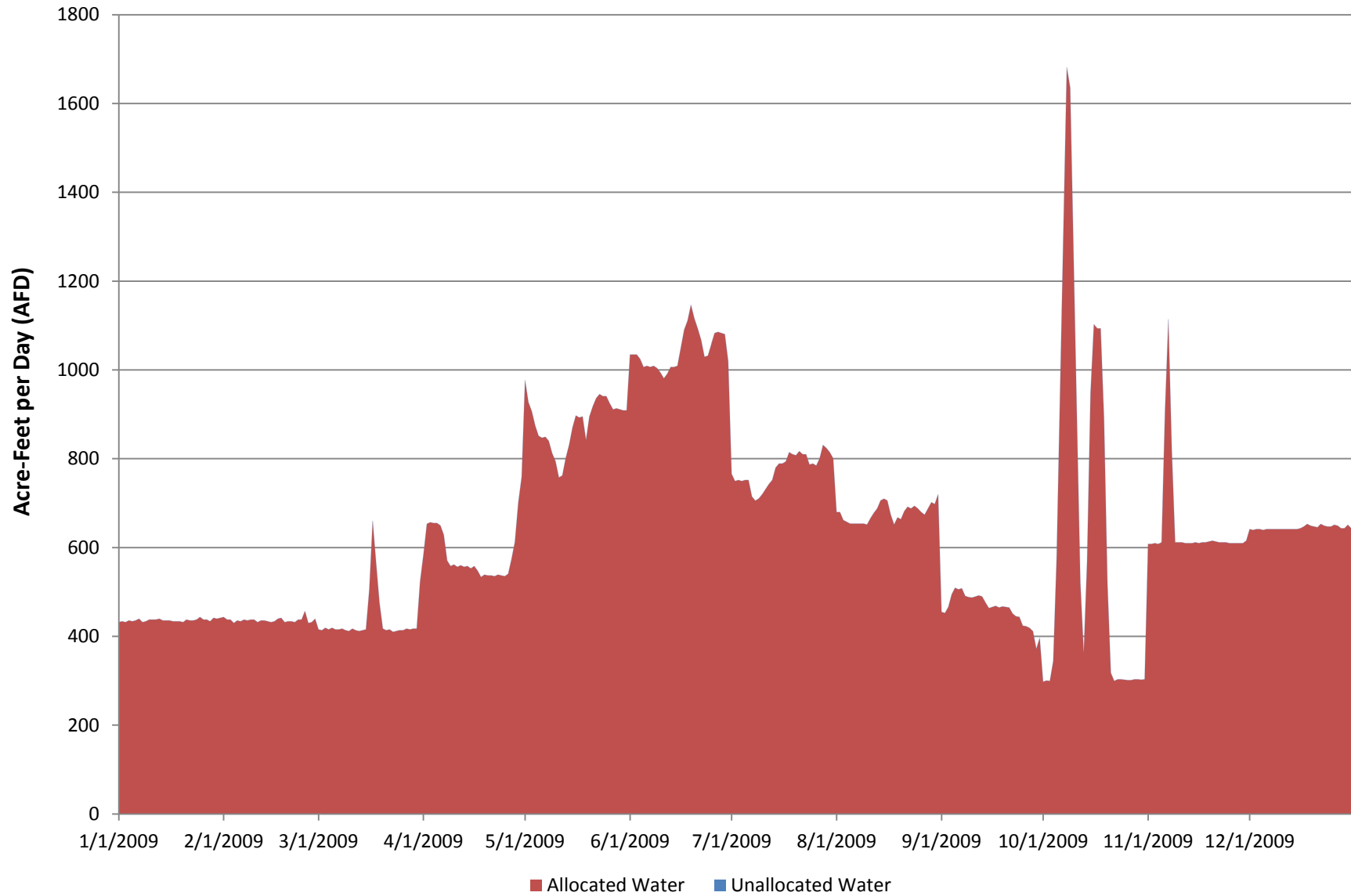
**Figure H-53: Daily Unallocated Water Calculation Downstream of Camanche Reservoir - 2007 hydrology (2040 diversion assumptions)**



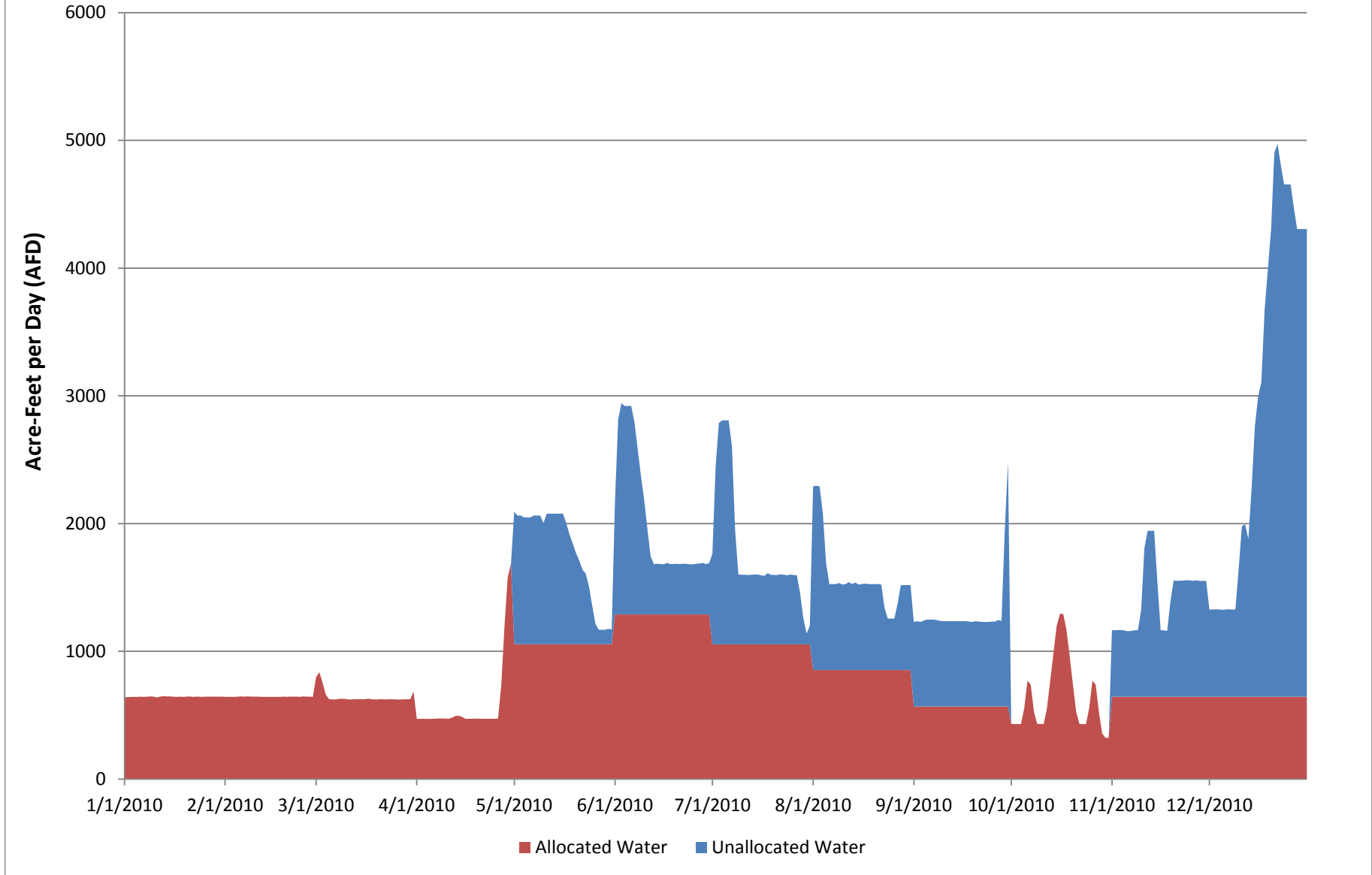
**Figure H-54: Daily Unallocated Water Calculation Downstream of Camanche Reservoir - 2008 hydrology (2040 diversion assumptions)**



**Figure H-55: Daily Unallocated Water Calculation Downstream of Camanche Reservoir - 2009 hydrology (2040 diversion assumptions)**

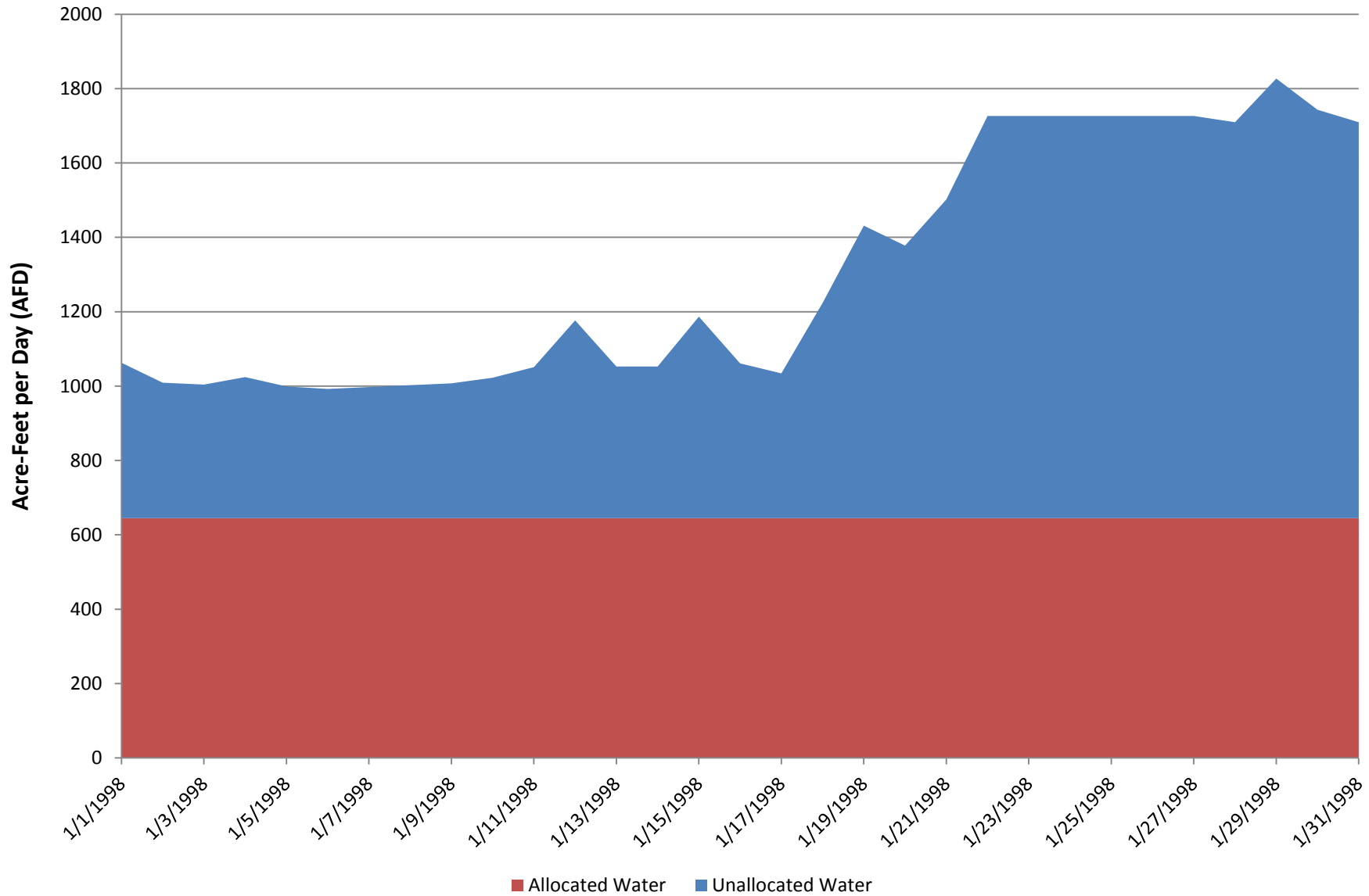


**Figure H-56: Daily Unallocated Water Calculation Downstream of Camanche Reservoir - 2010 hydrology (2040 diversion assumptions)**

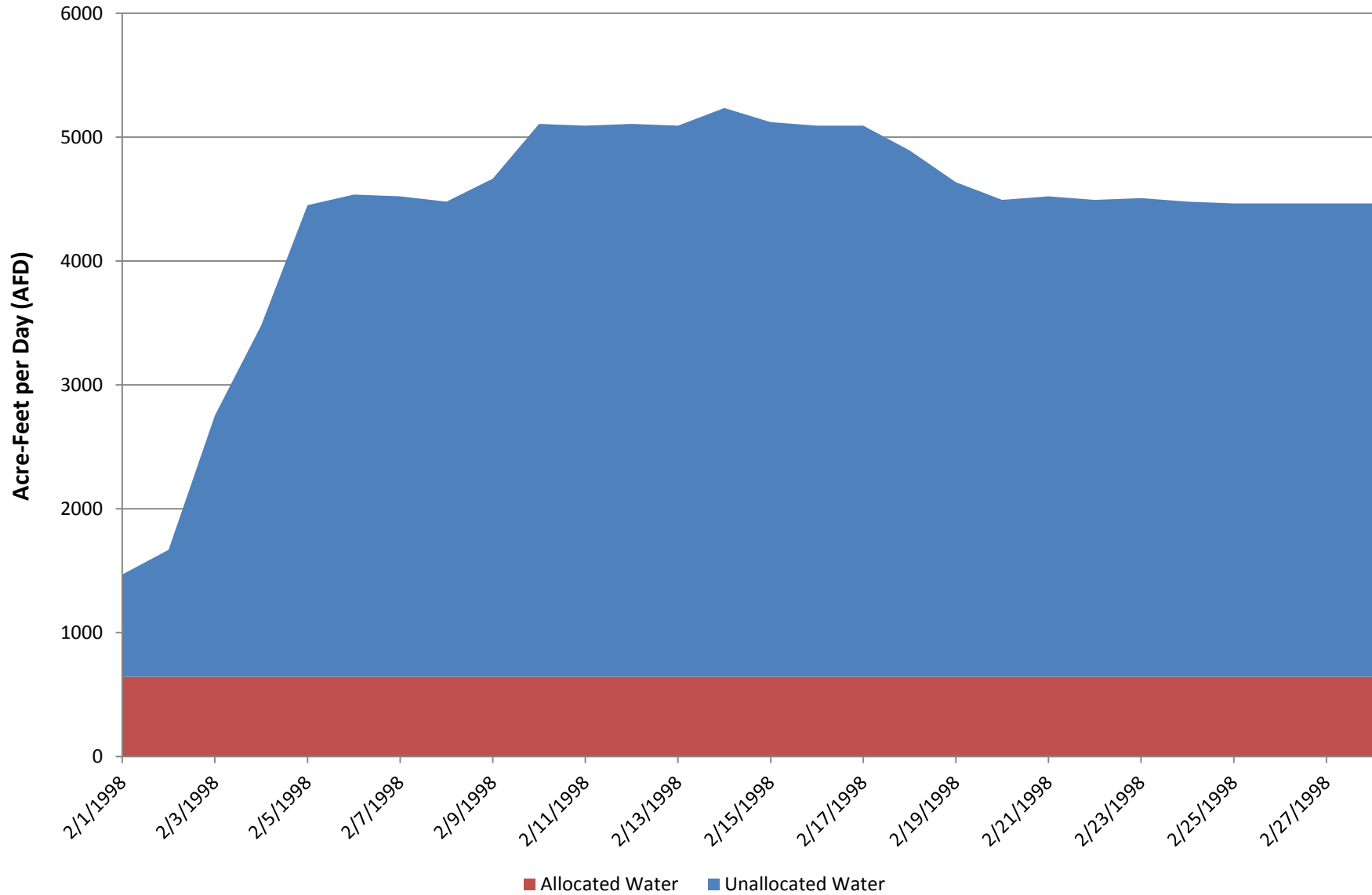




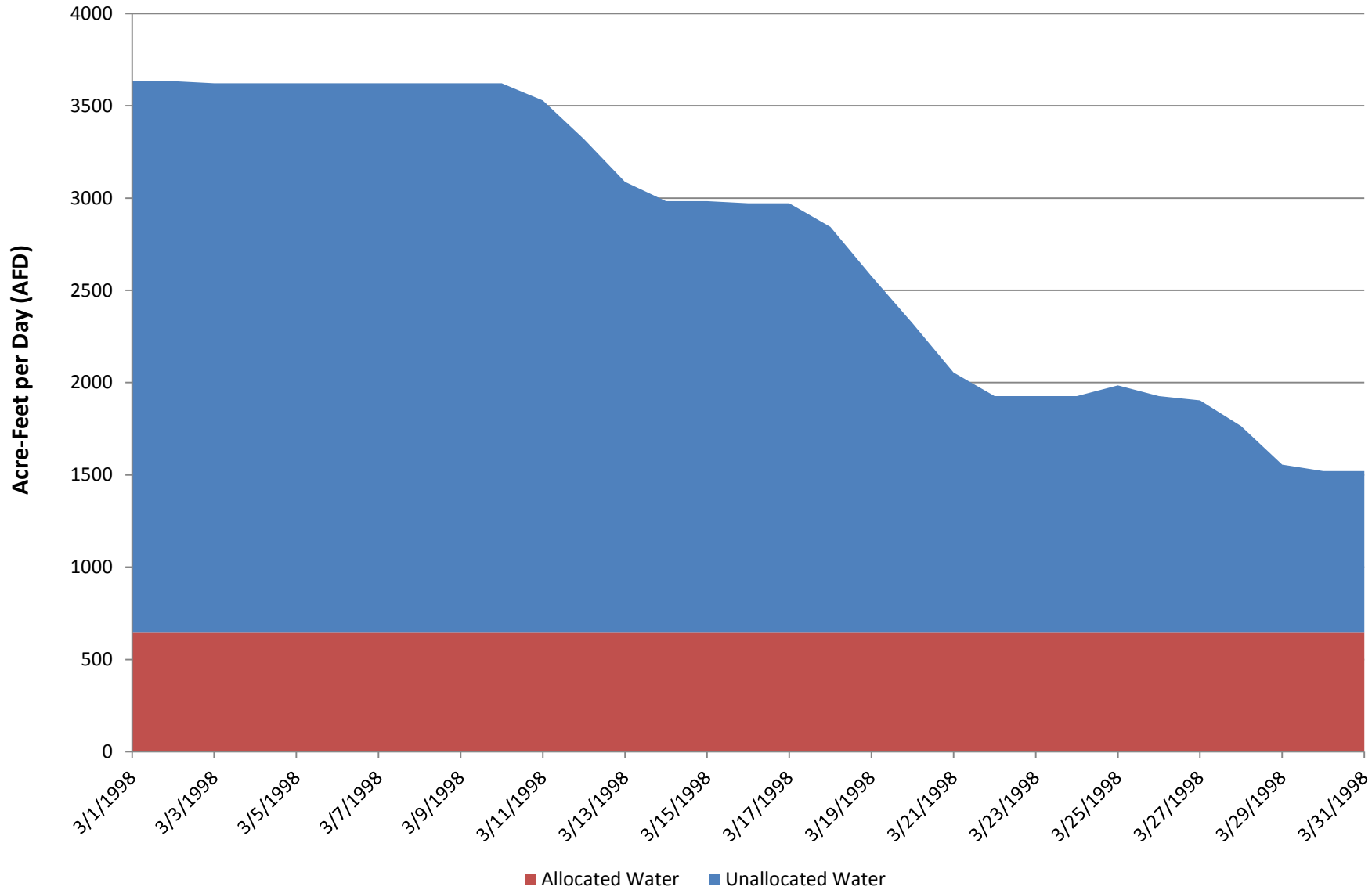
**Figure H-57: Daily Unallocated Water Calculation Downstream of Camanche Reservoir - January 1998 hydrology (2040 diversion assumptions)**



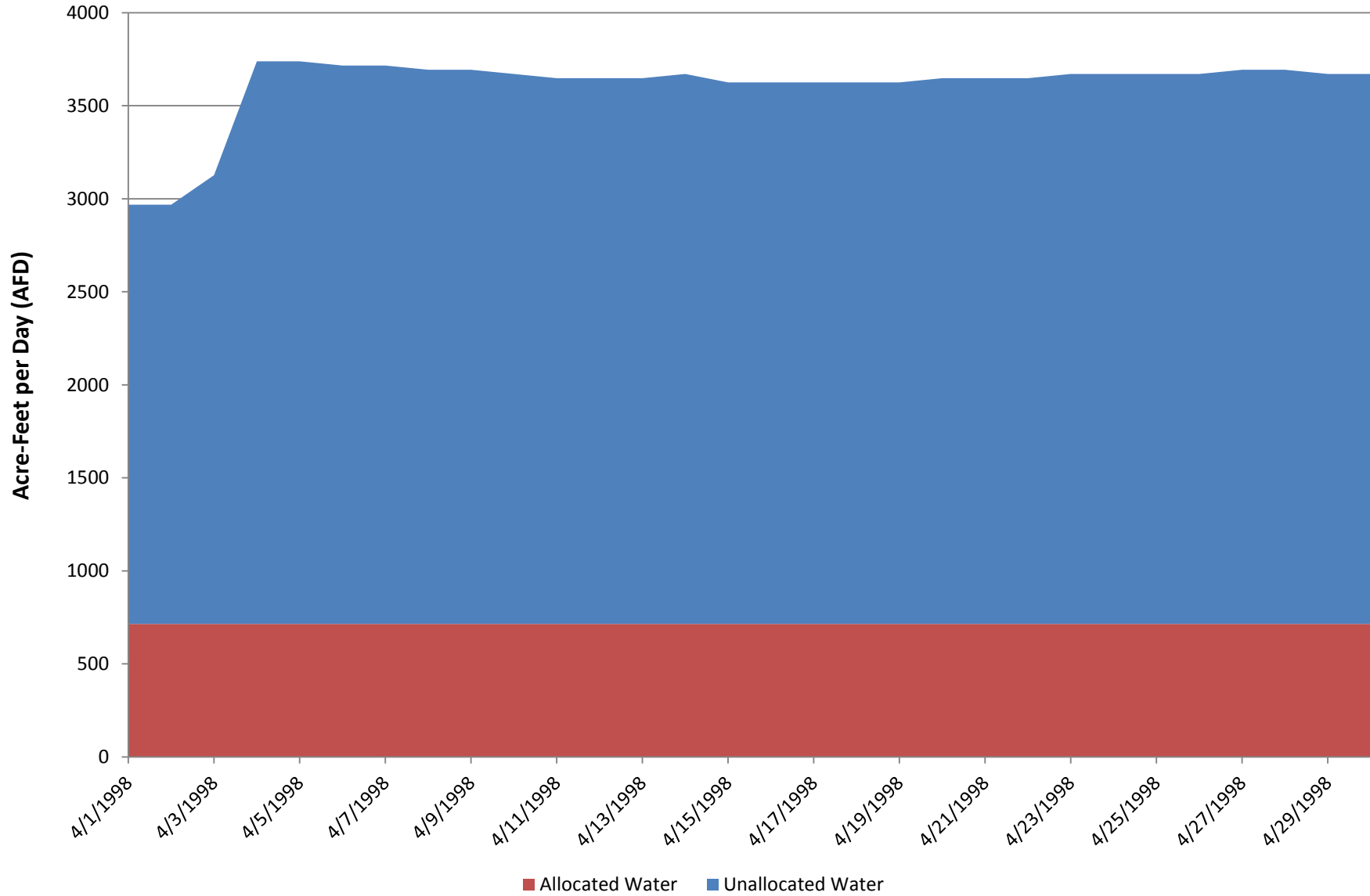
**Figure H-58: Daily Unallocated Water Calculation Downstream of Camanche Reservoir - February 1998 hydrology (2040 diversion assumptions)**



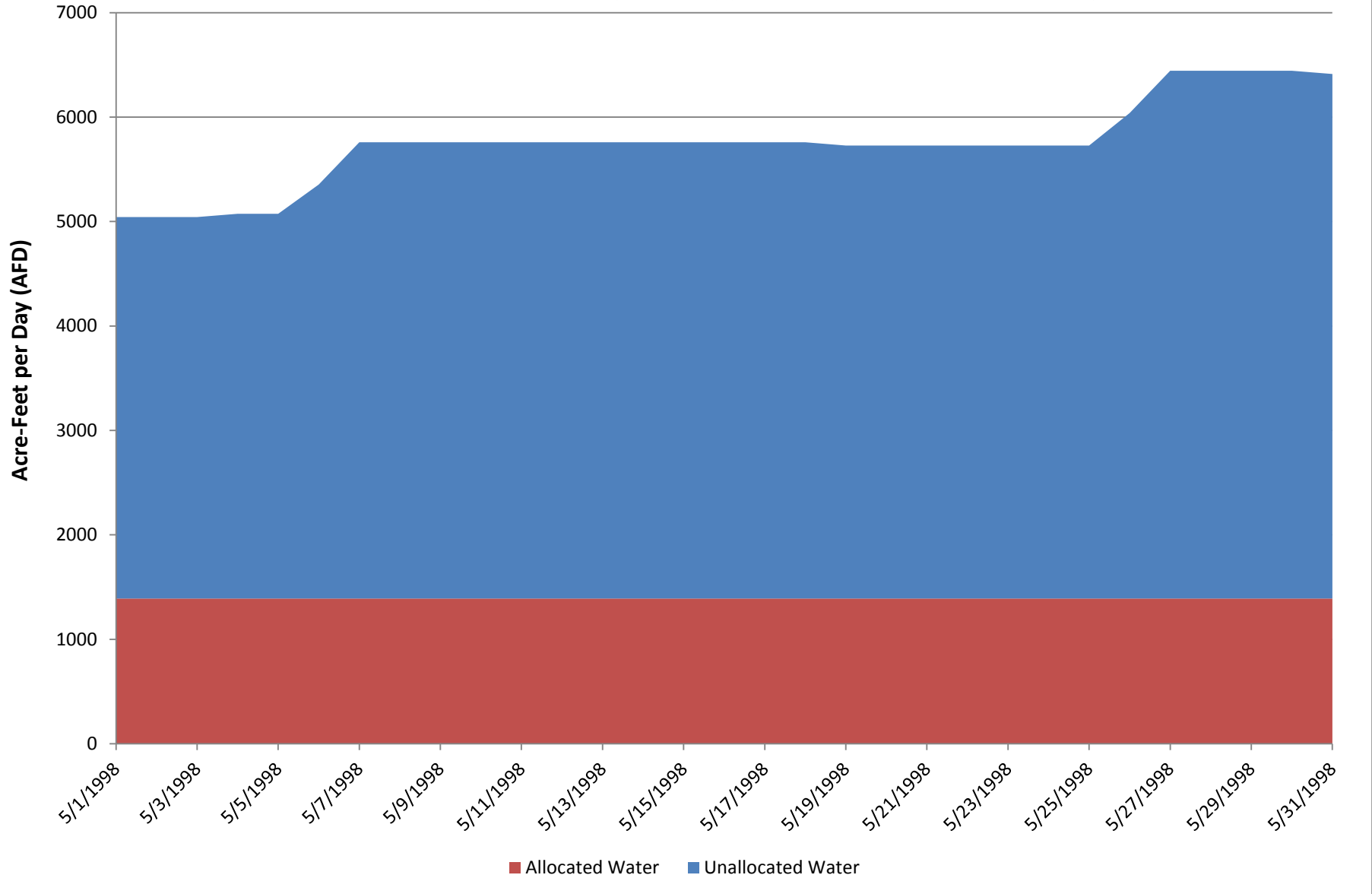
**Figure H-59: Daily Unallocated Water Calculation Downstream of Camanche Reservoir - March 1998 hydrology (2040 diversion assumptions)**



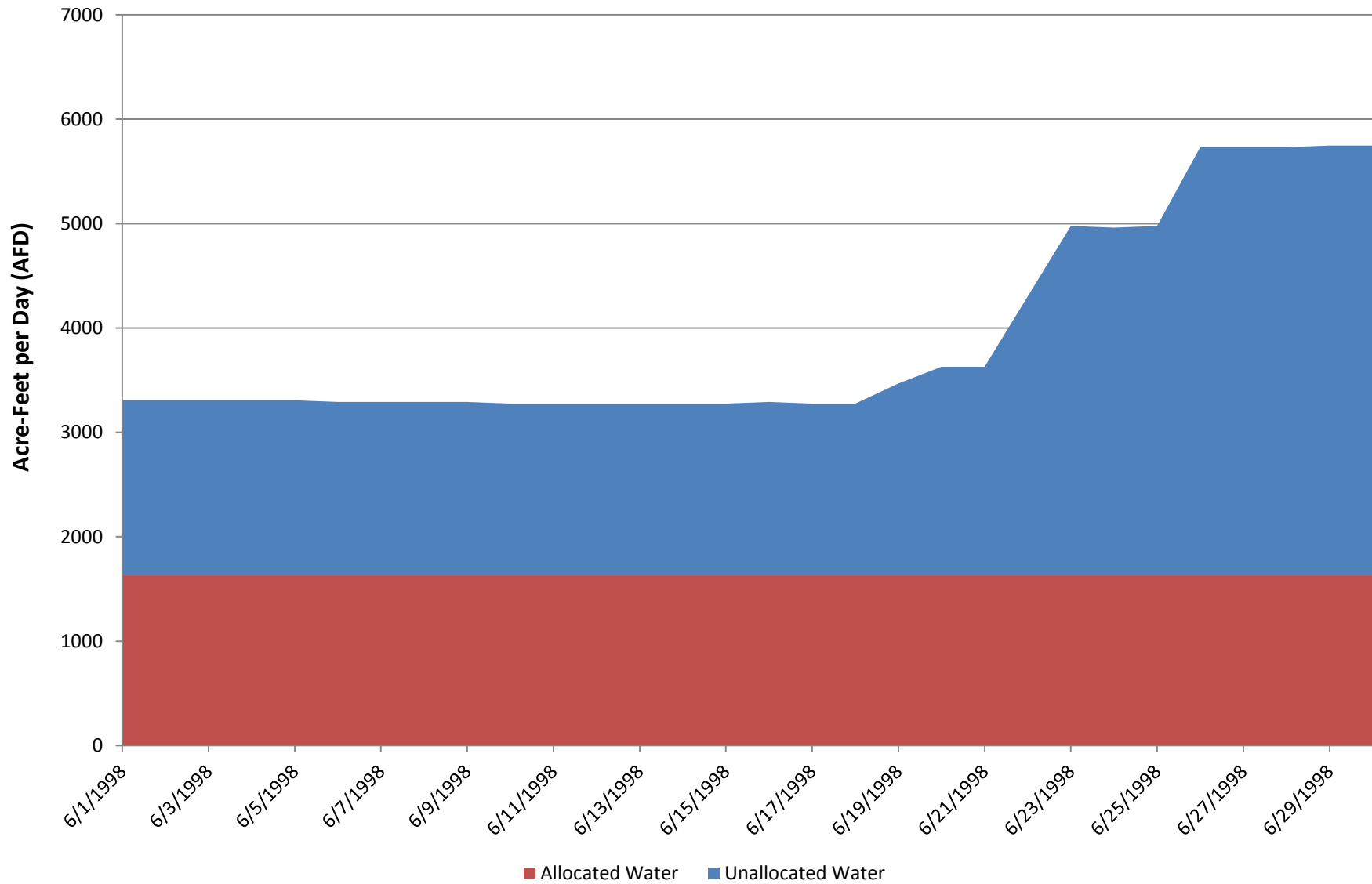
**Figure H-60: Daily Unallocated Water Calculation Downstream of Camanche Reservoir - April 1998 hydrology (2040 diversion assumptions)**



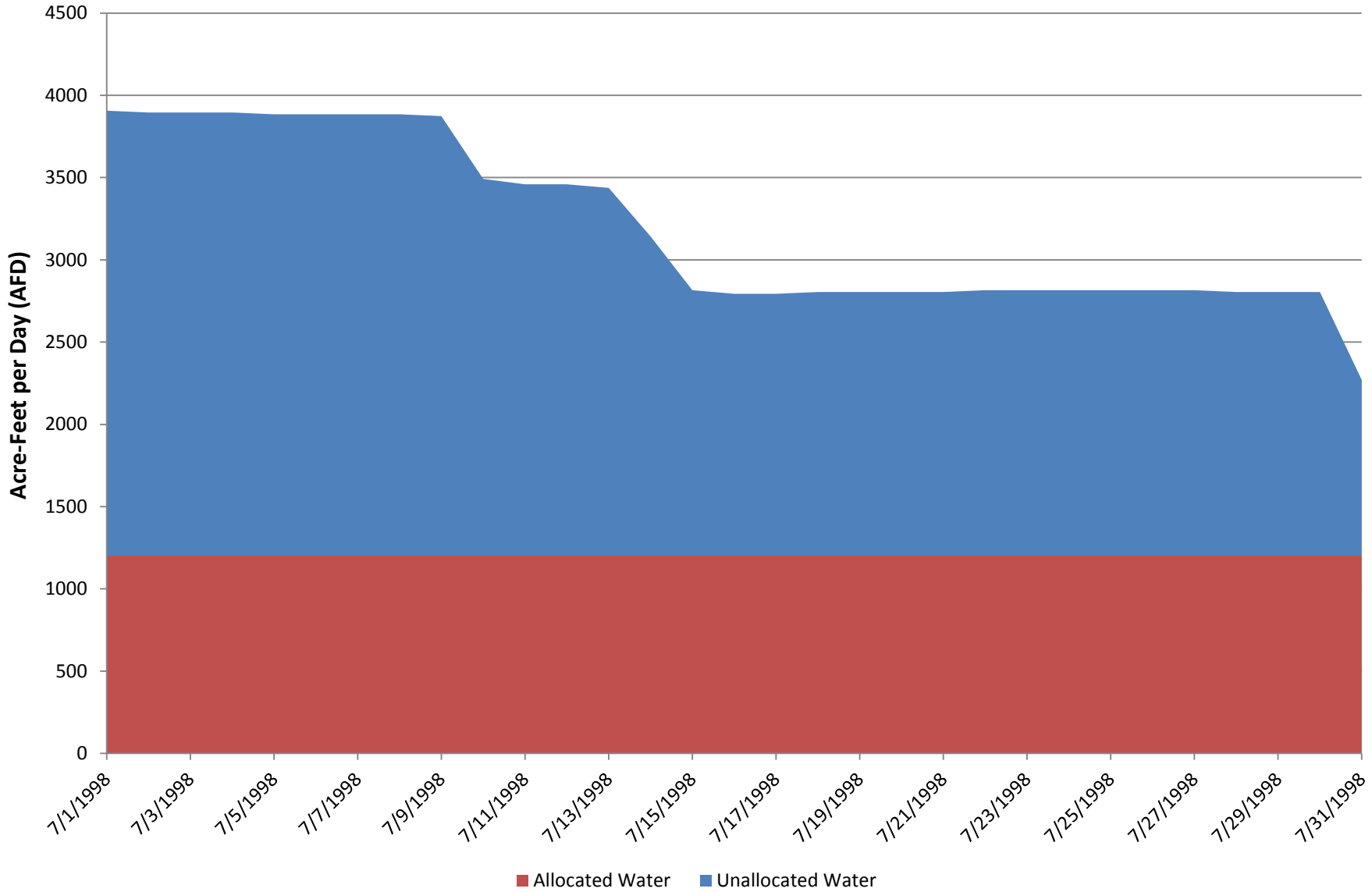
**Figure H-61: Daily Unallocated Water Calculation Downstream of Camanche Reservoir - May 1998 hydrology (2040 diversion assumptions)**



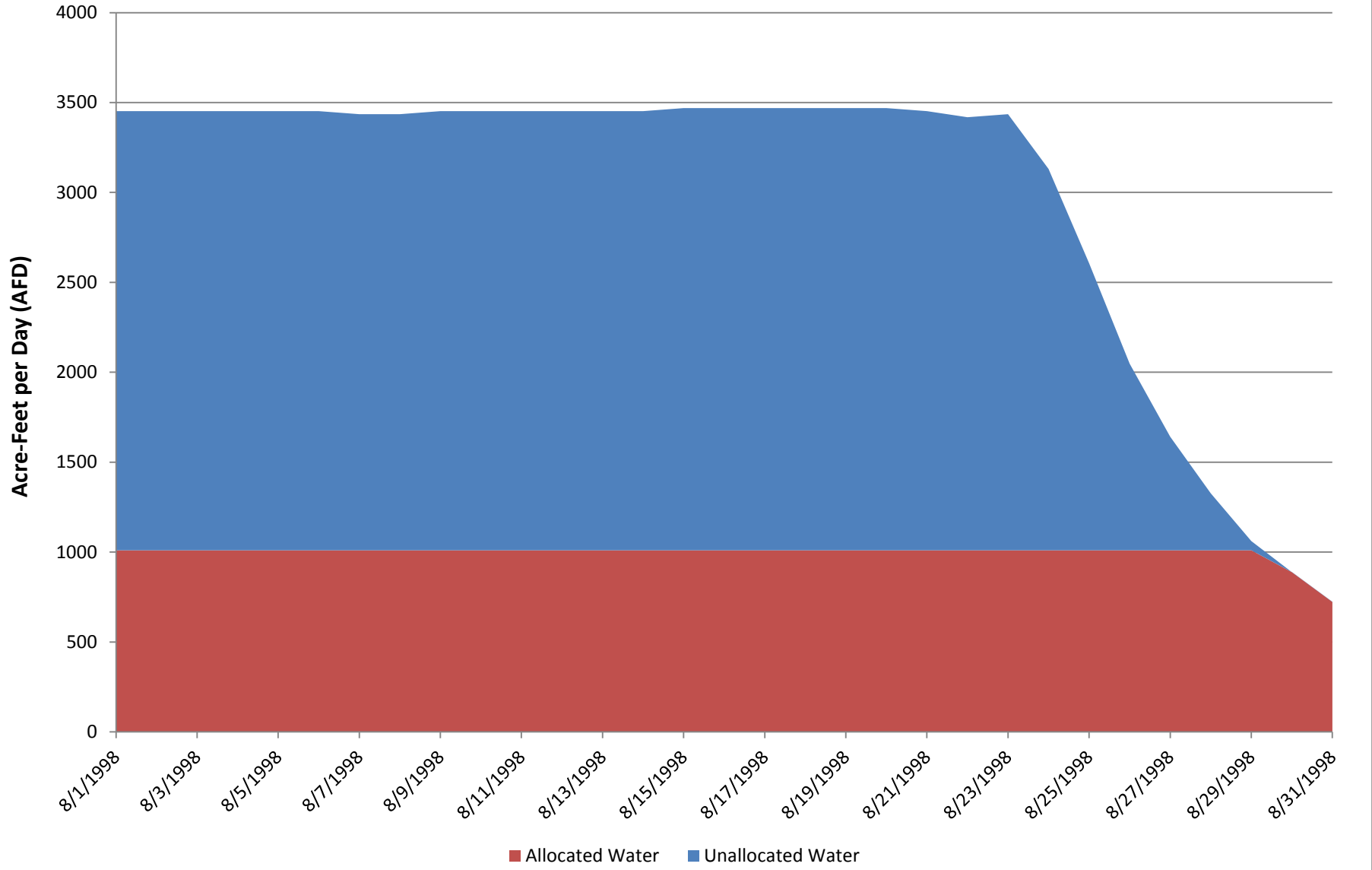
**Figure H-62: Daily Unallocated Water Calculation Downstream of Camanche Reservoir - June 1998 hydrology (2040 diversion assumptions)**



**Figure H-63: Daily Unallocated Water Calculation Downstream of Camanche Reservoir - July 1998 hydrology (2040 diversion assumptions)**

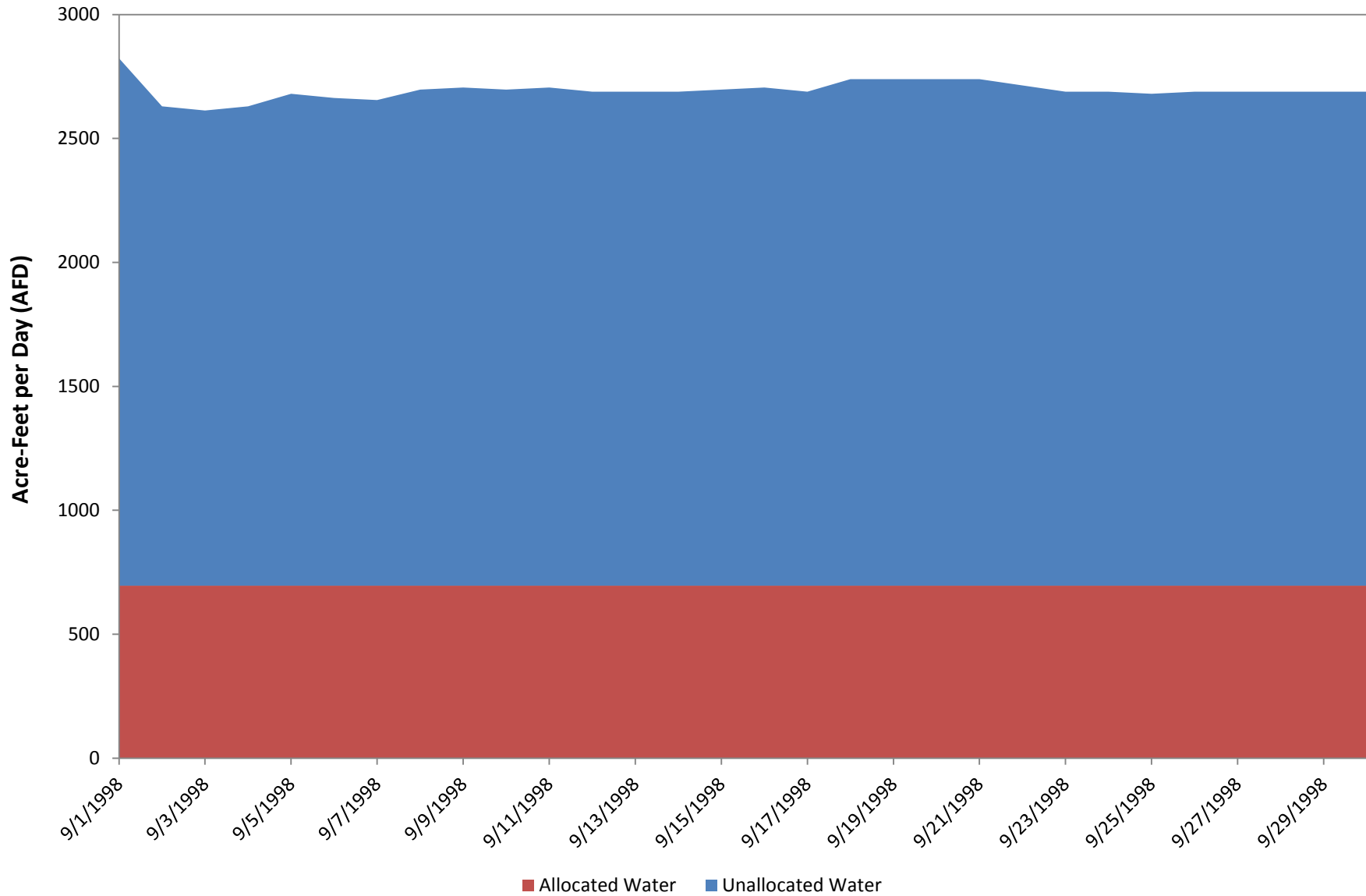


**Figure H-64: Daily Unallocated Water Calculation Downstream of Camanche Reservoir - August 1998 hydrology (2040 diversion assumptions)**

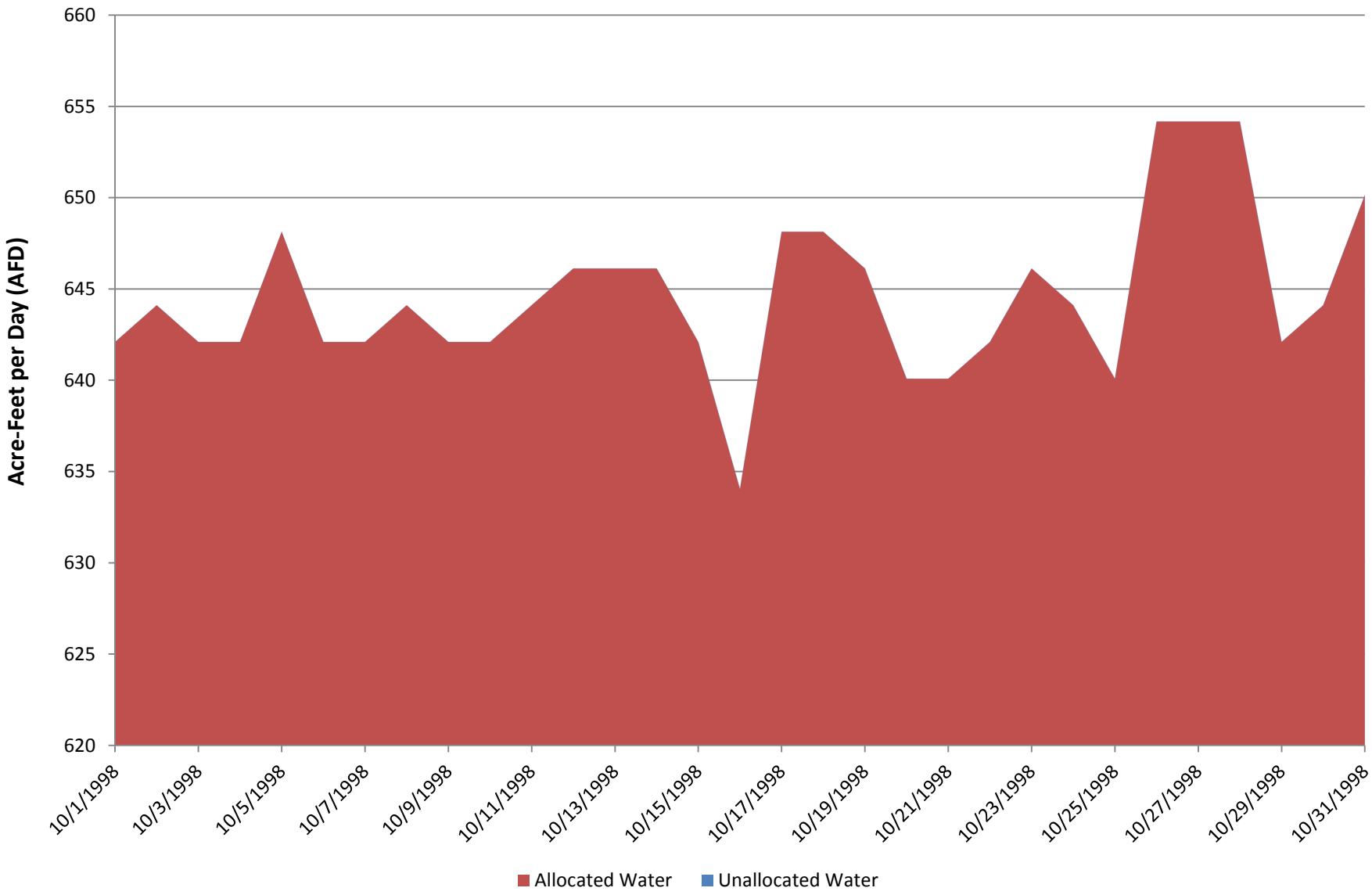




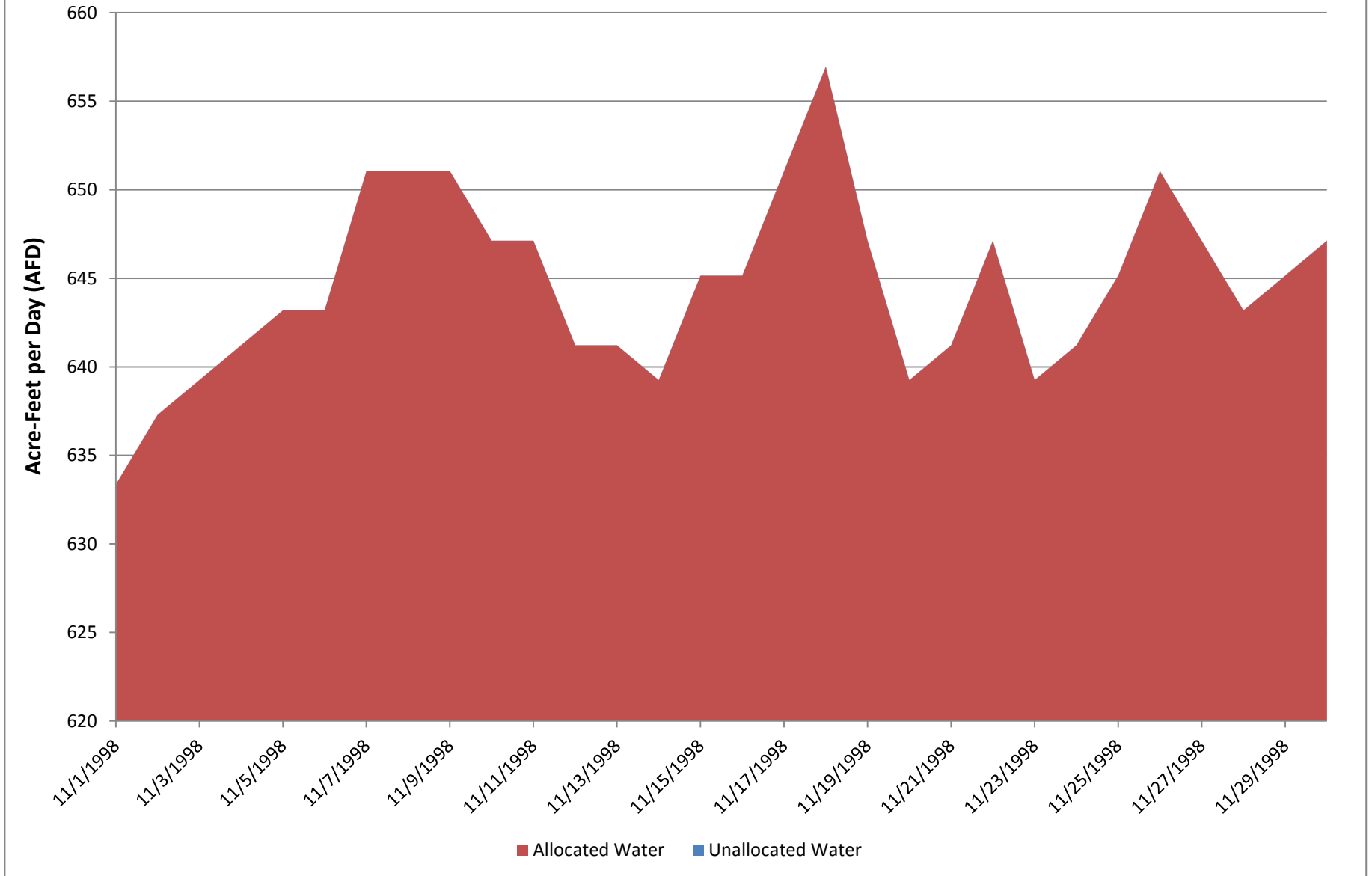
**Figure H-65: Daily Unallocated Water Calculation Downstream of Camanche Reservoir - September 1998 hydrology (2040 diversion assumptions)**



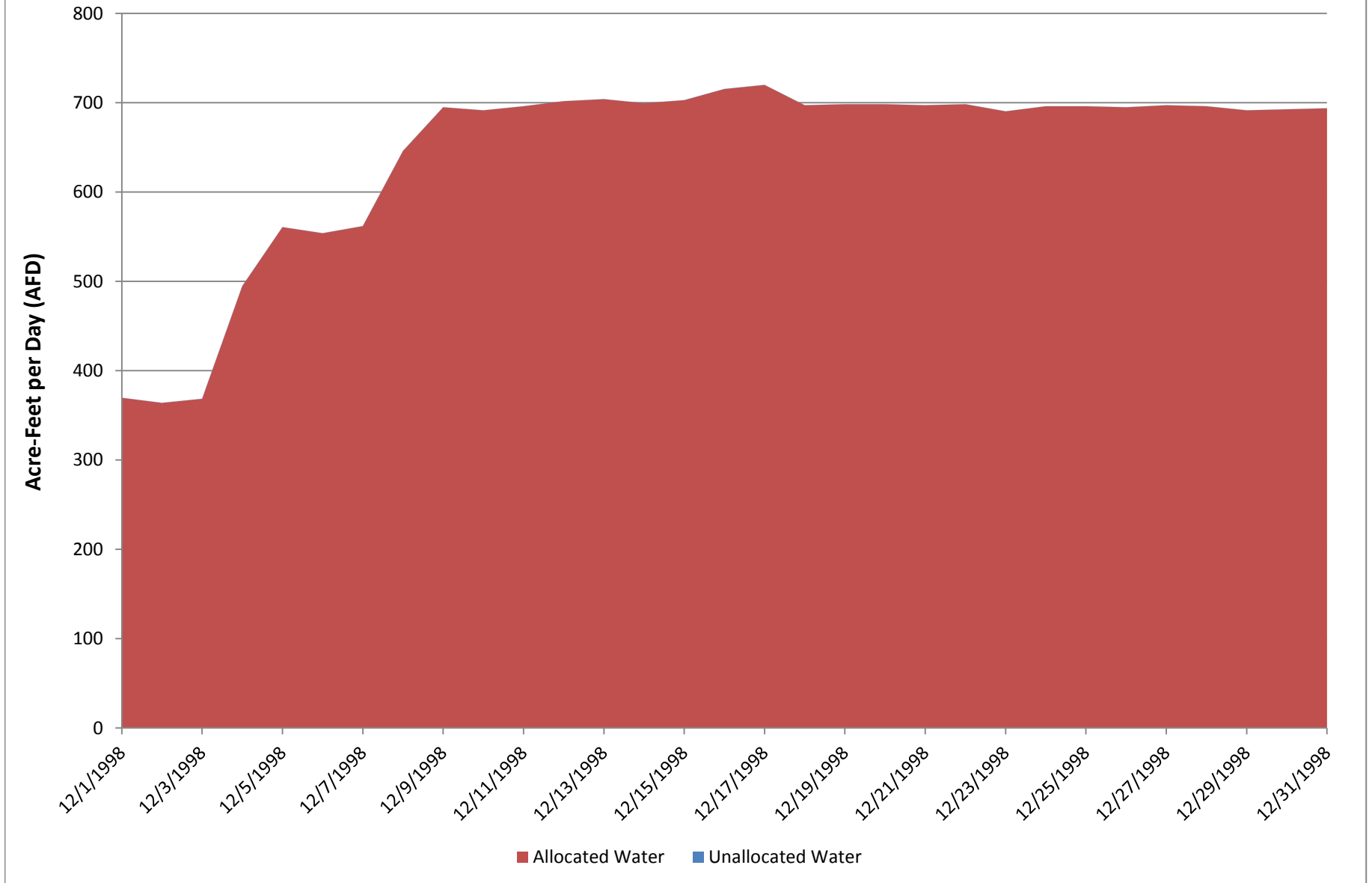
**Figure H-66: Daily Unallocated Water Calculation Downstream of Camanche Reservoir - October 1998 hydrology (2040 diversion assumptions)**



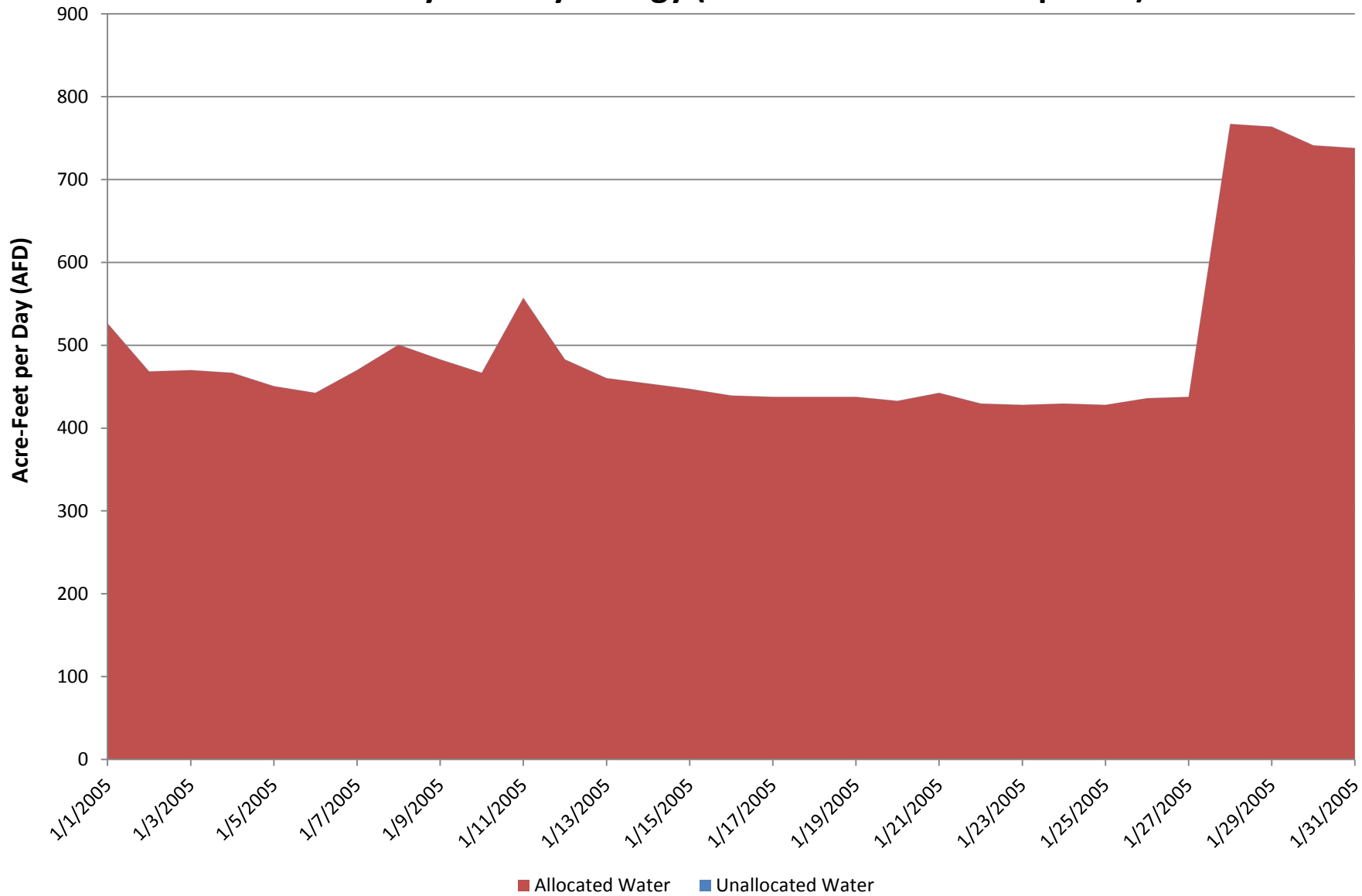
**Figure H-67: Daily Unallocated Water Calculation Downstream of Camanche Reservoir - November 1998 hydrology (2040 diversion assumptions)**



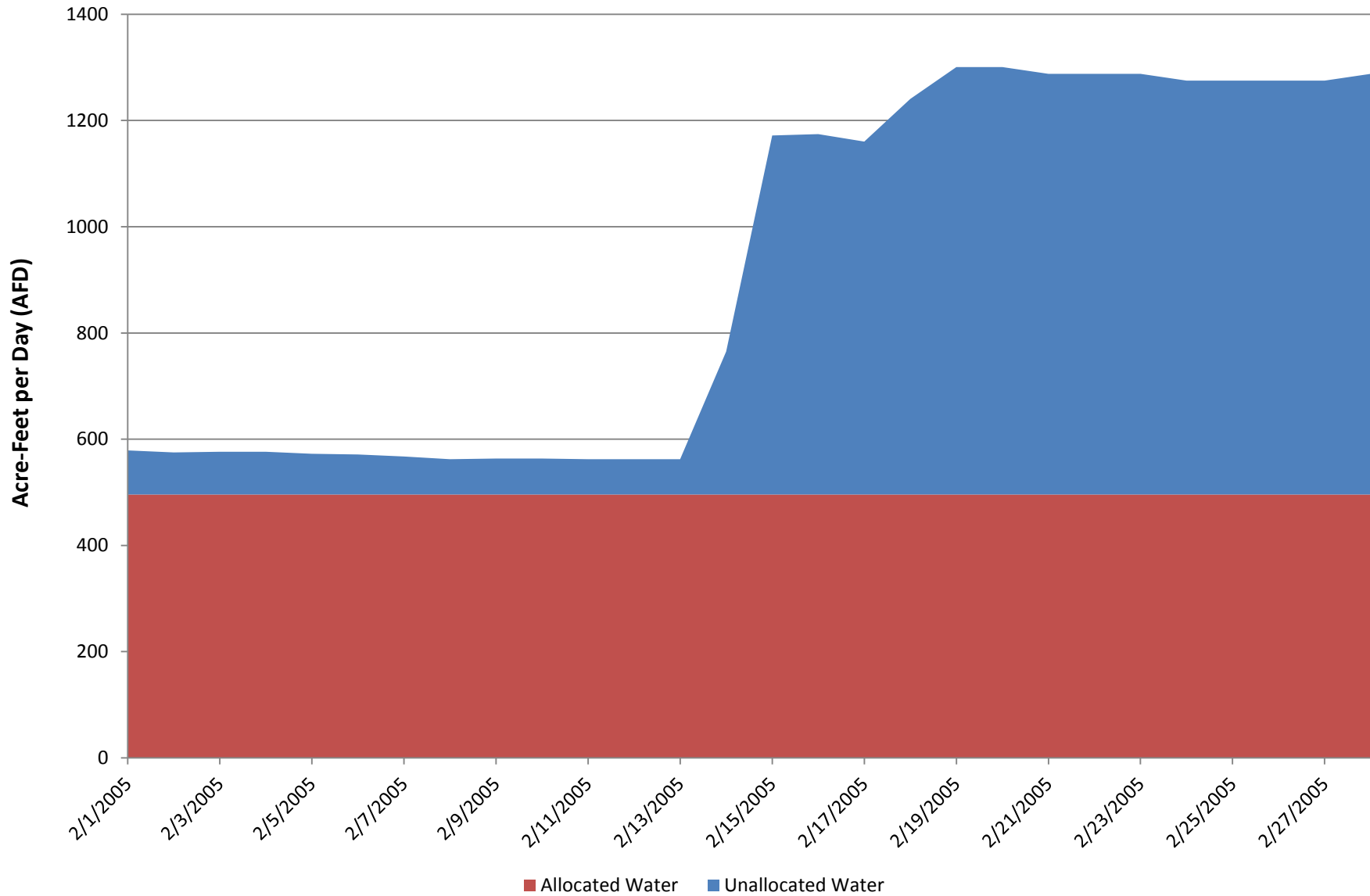
**Figure H-68: Daily Unallocated Water Calculation Downstream of Camanche Reservoir - December 1998 hydrology (2040 diversion assumptions)**



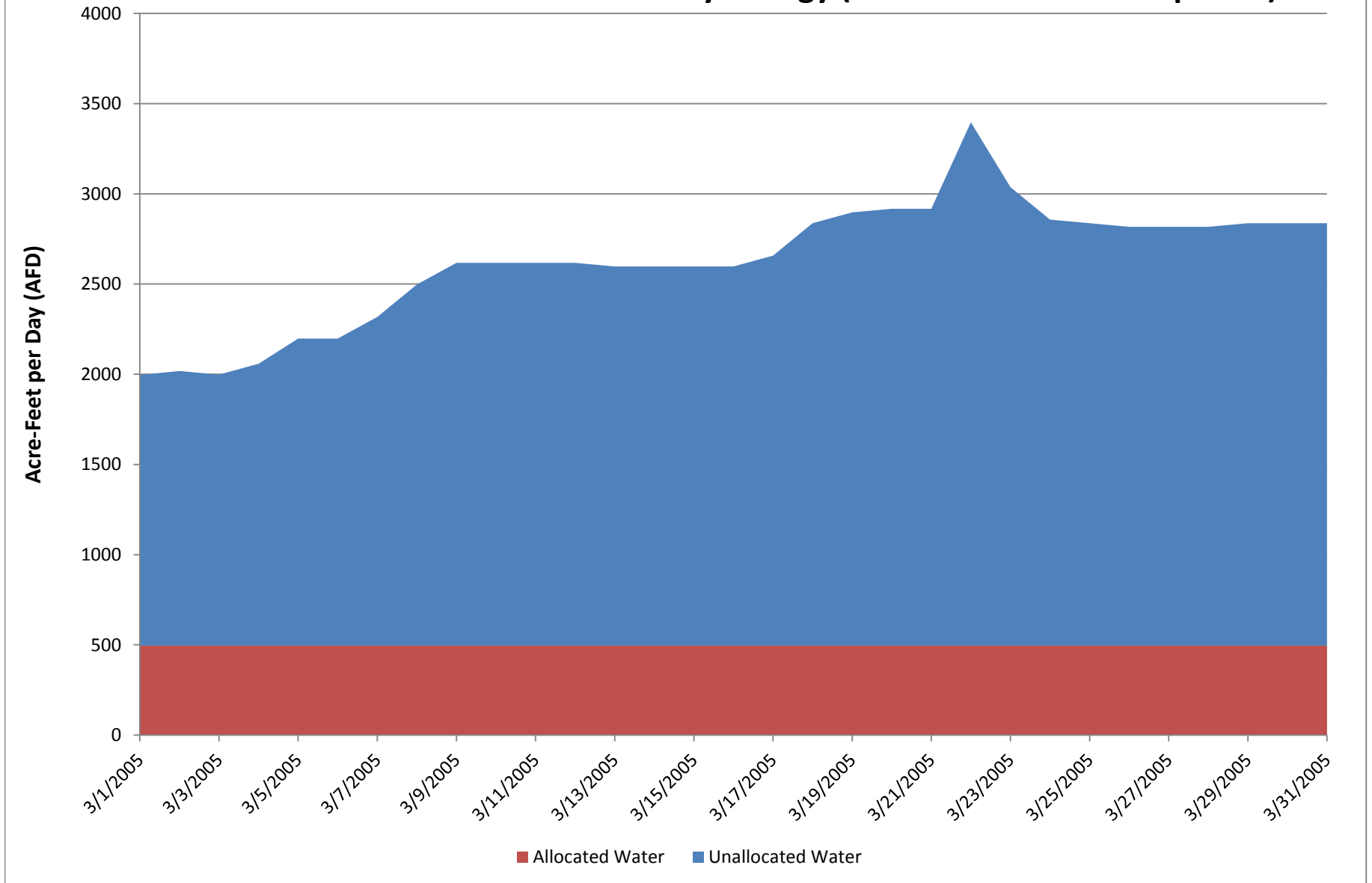
**Figure H-69: Daily Unallocated Water Calculation Downstream of Camanche Reservoir - January 2005 hydrology (2040 diversion assumptions)**



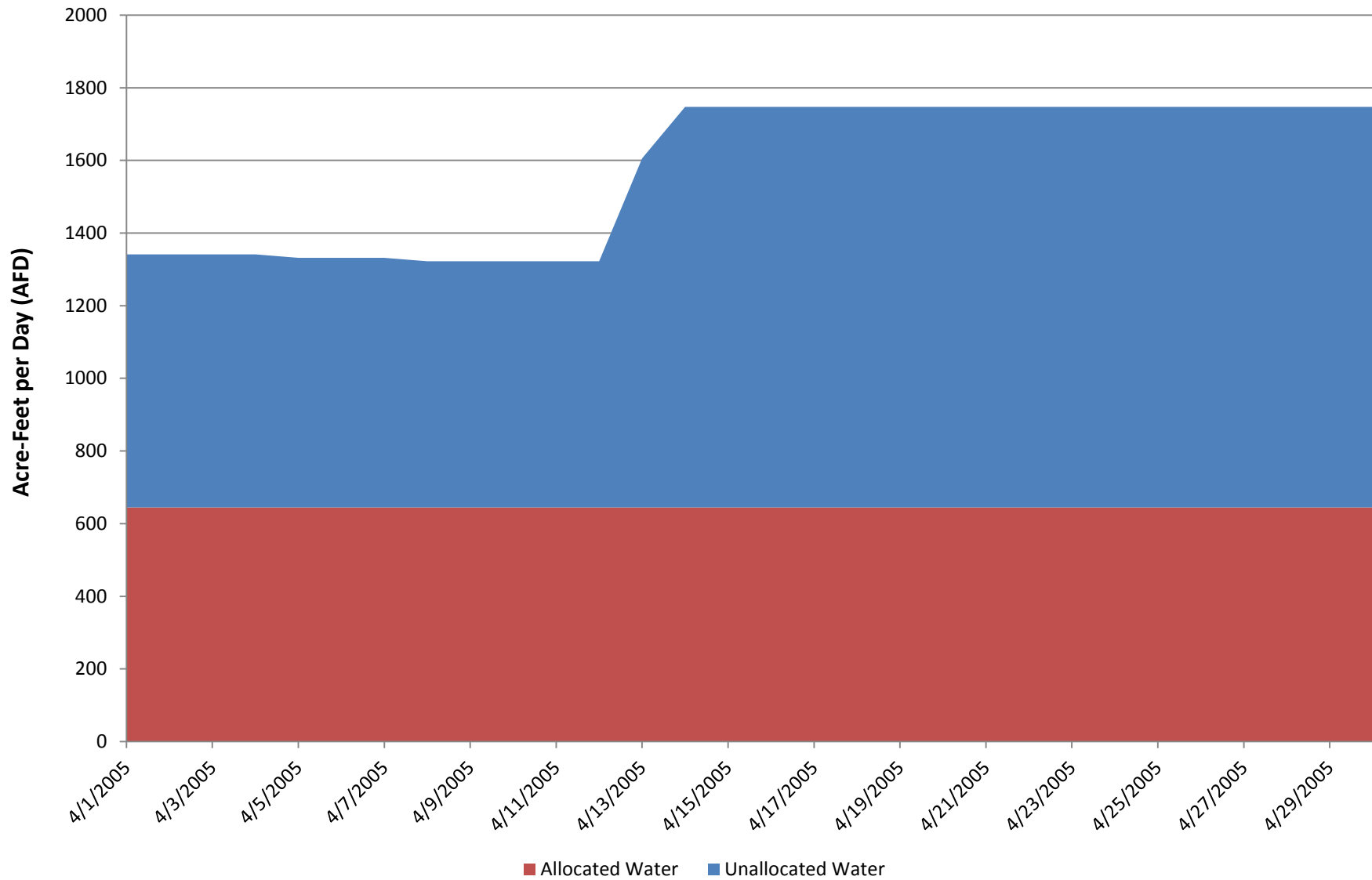
**Figure H-70: Daily Unallocated Water Calculation Downstream of Camanche Reservoir - February 2005 hydrology (2040 diversion assumptions)**



**Figure H-71: Daily Unallocated Water Calculation Downstream of Camanche Reservoir - March 2005 hydrology (2040 diversion assumptions)**

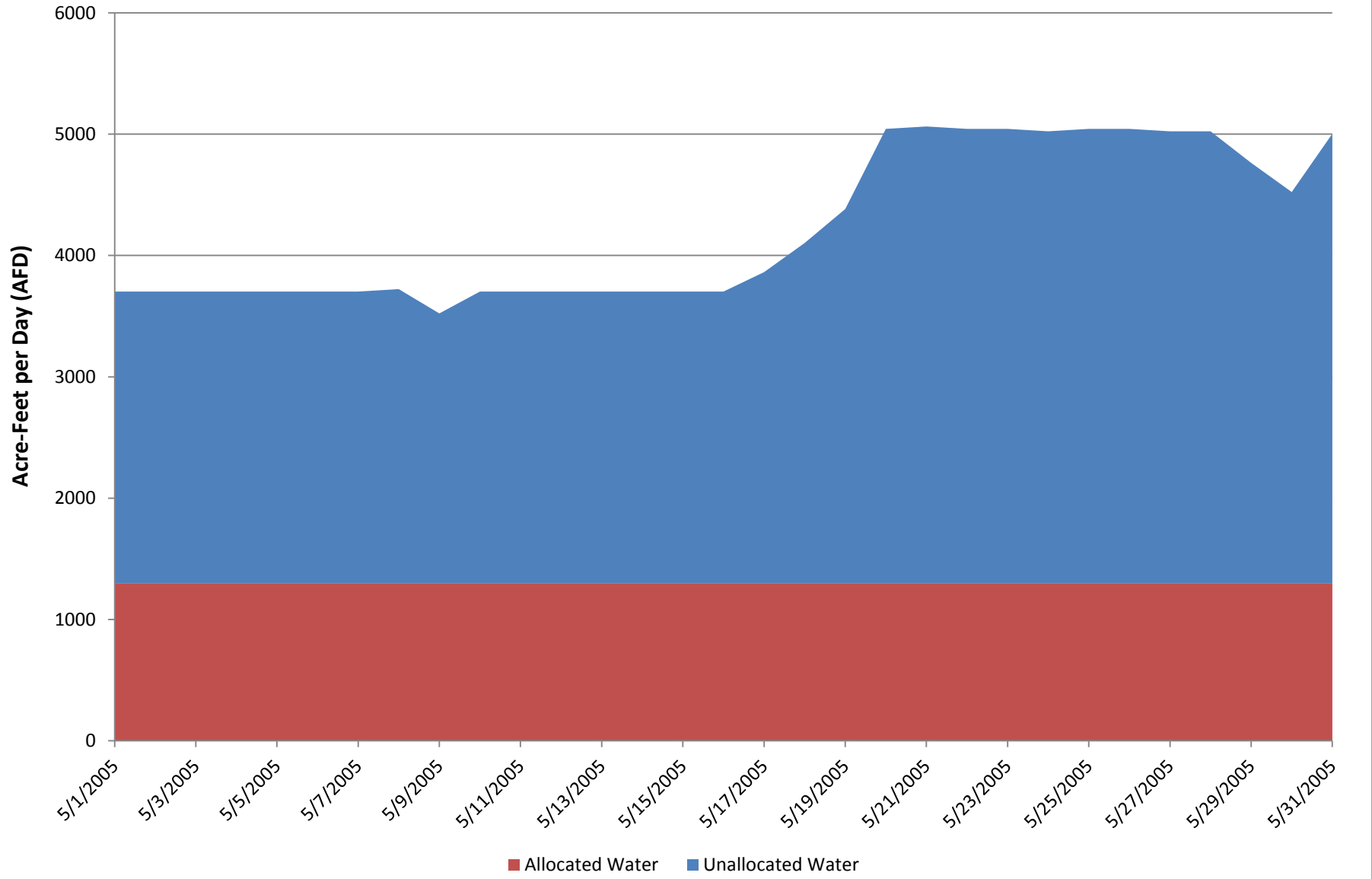


**Figure H-72: Daily Unallocated Water Calculation Downstream of Camanche Reservoir - April 2005 hydrology (2040 diversion assumptions)**

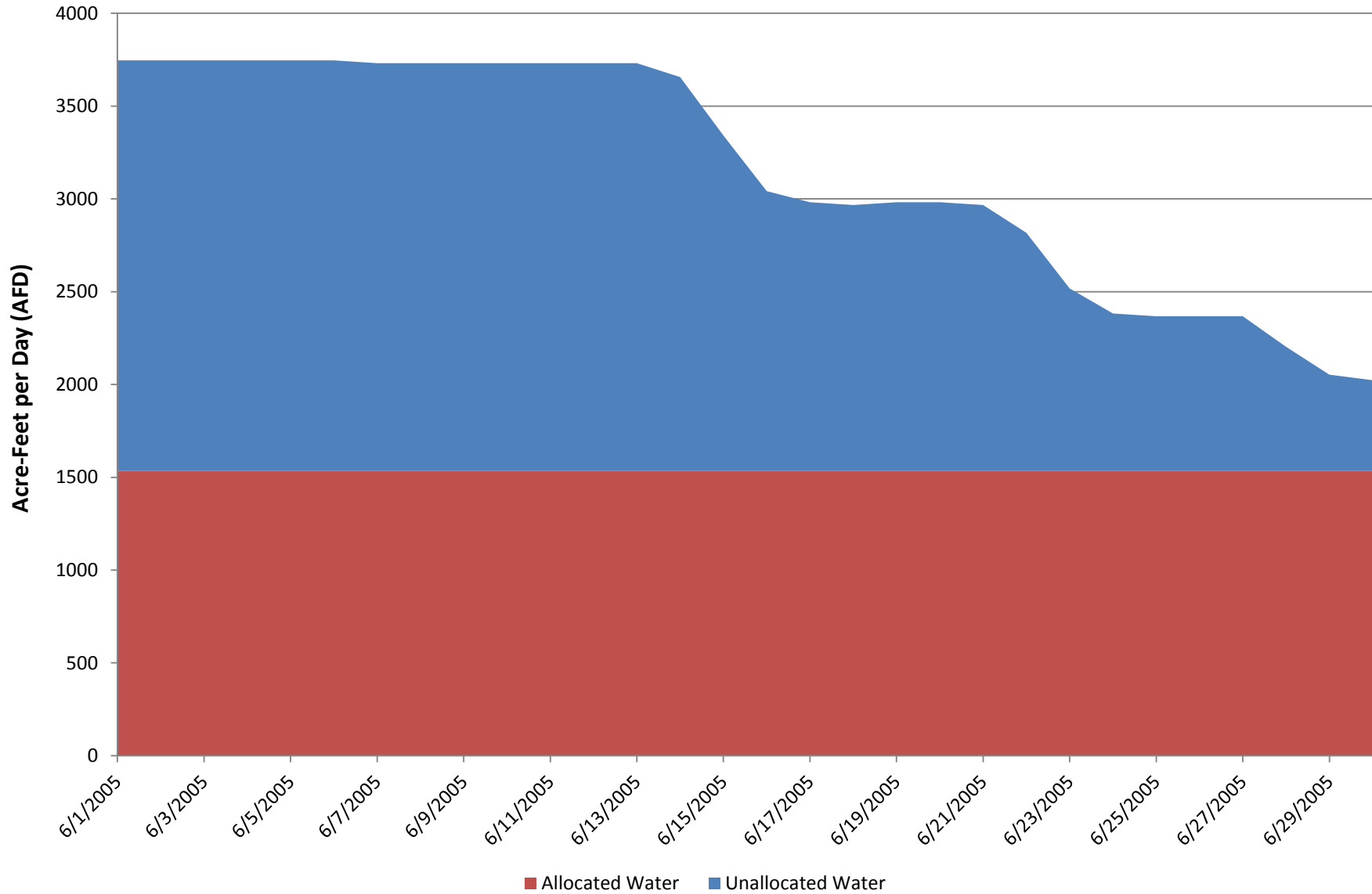




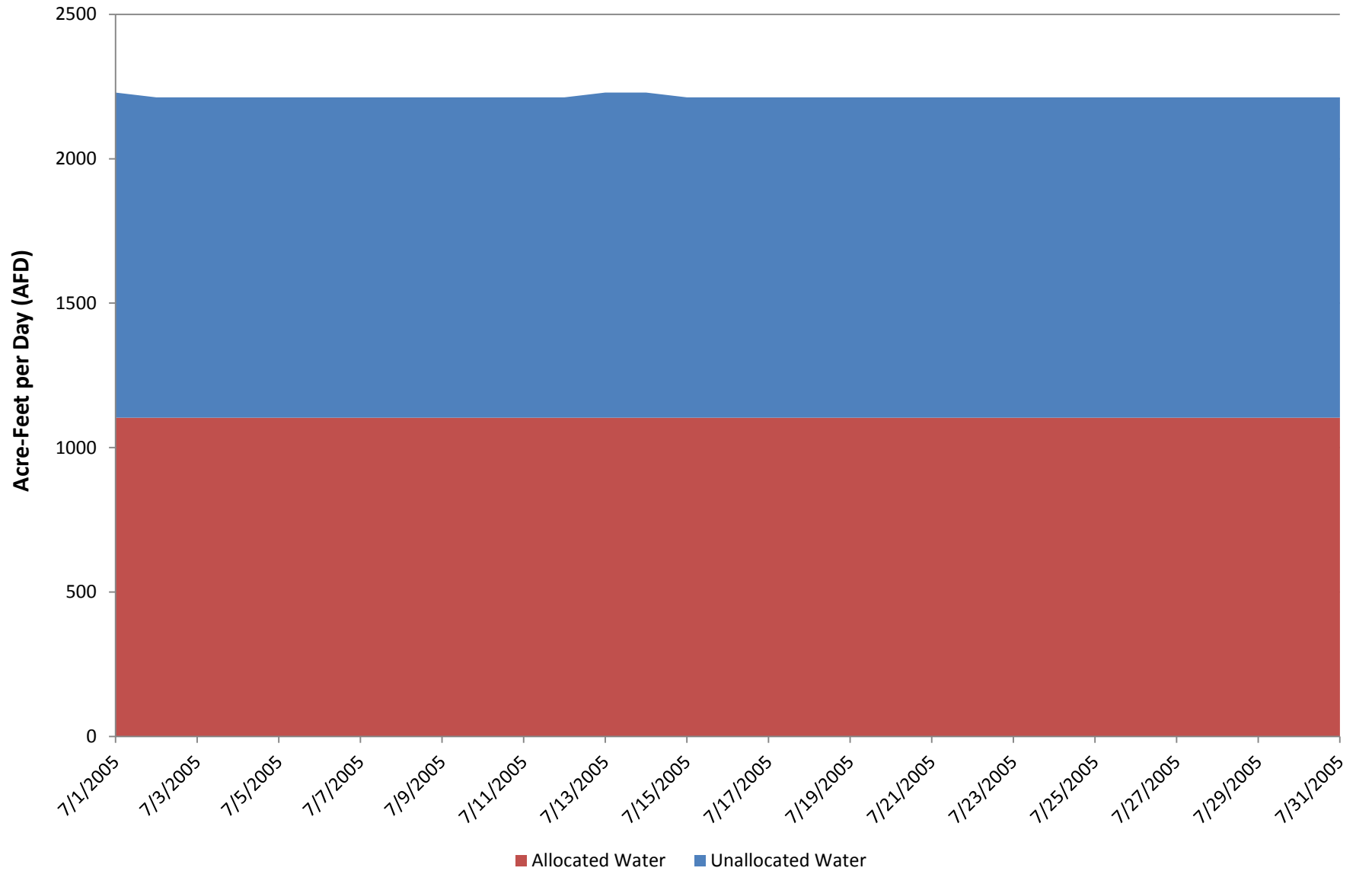
**Figure H-73: Daily Unallocated Water Calculation Downstream of Camanche Reservoir - May 2005 hydrology (2040 diversion assumptions)**



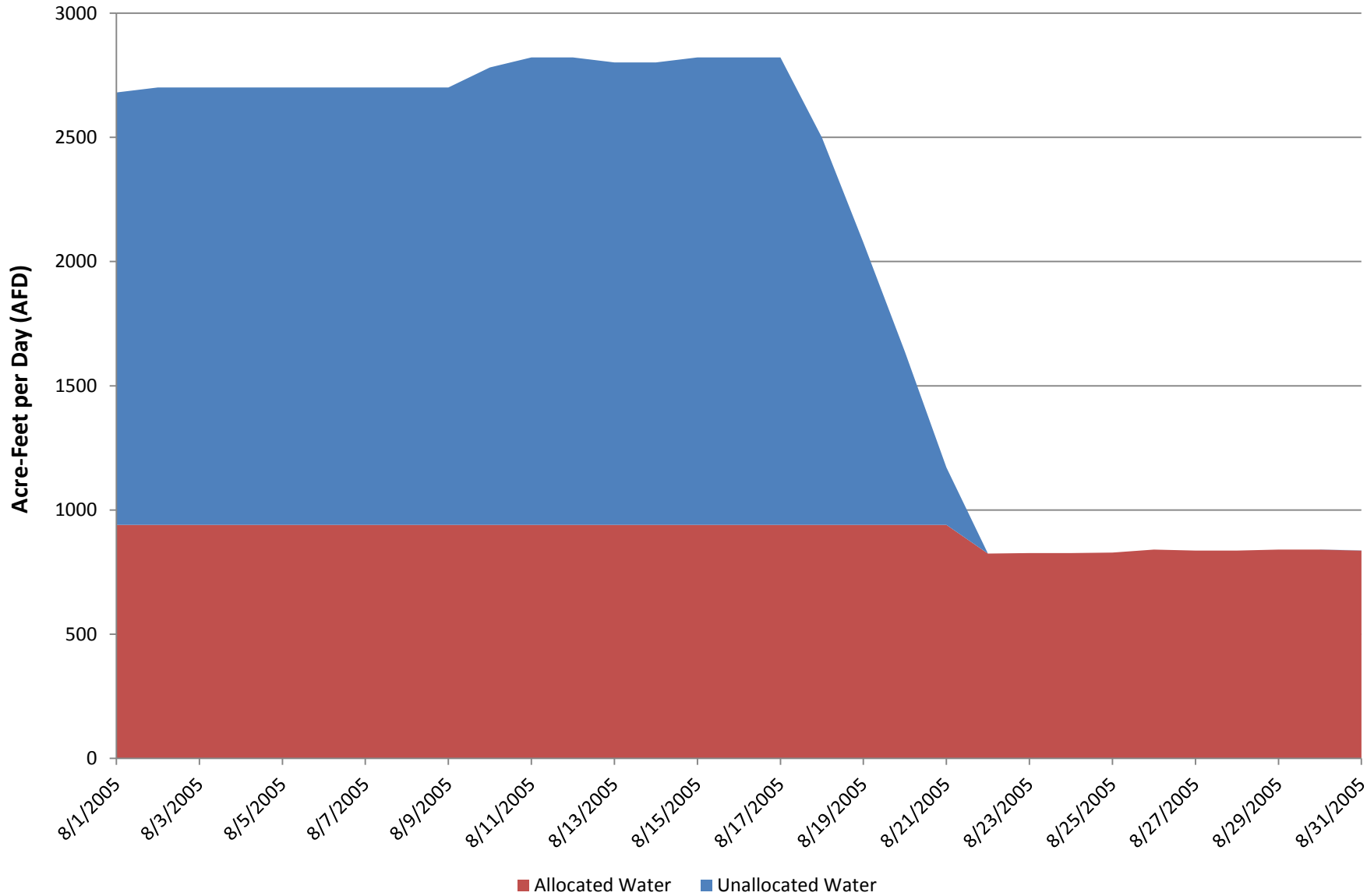
**Figure H-74: Daily Unallocated Water Calculation Downstream of Camanche Reservoir - June 2005 hydrology (2040 diversion assumptions)**



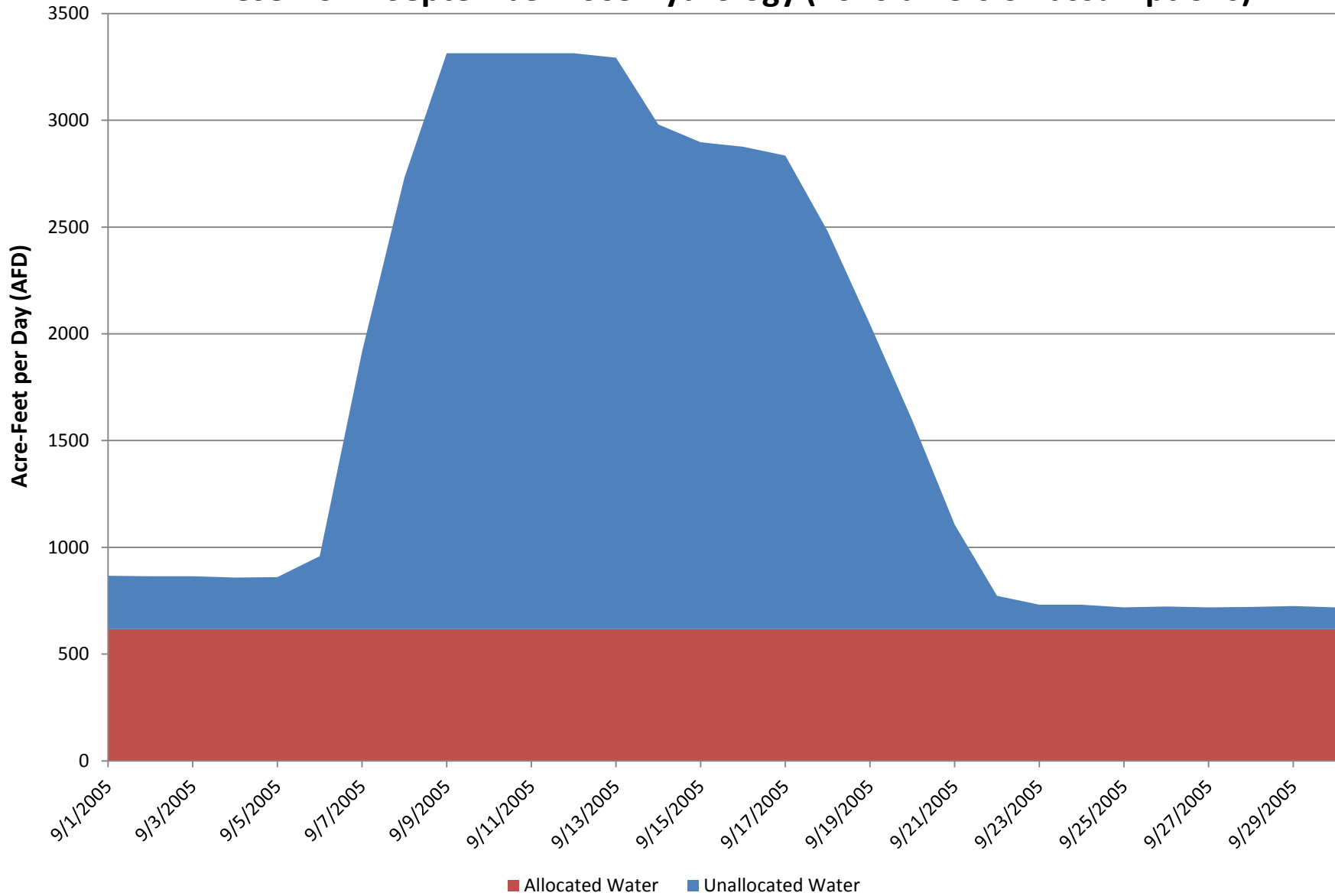
**Figure H-75: Daily Unallocated Water Calculation Downstream of Camanche Reservoir - July 2005 hydrology (2040 diversion assumptions)**



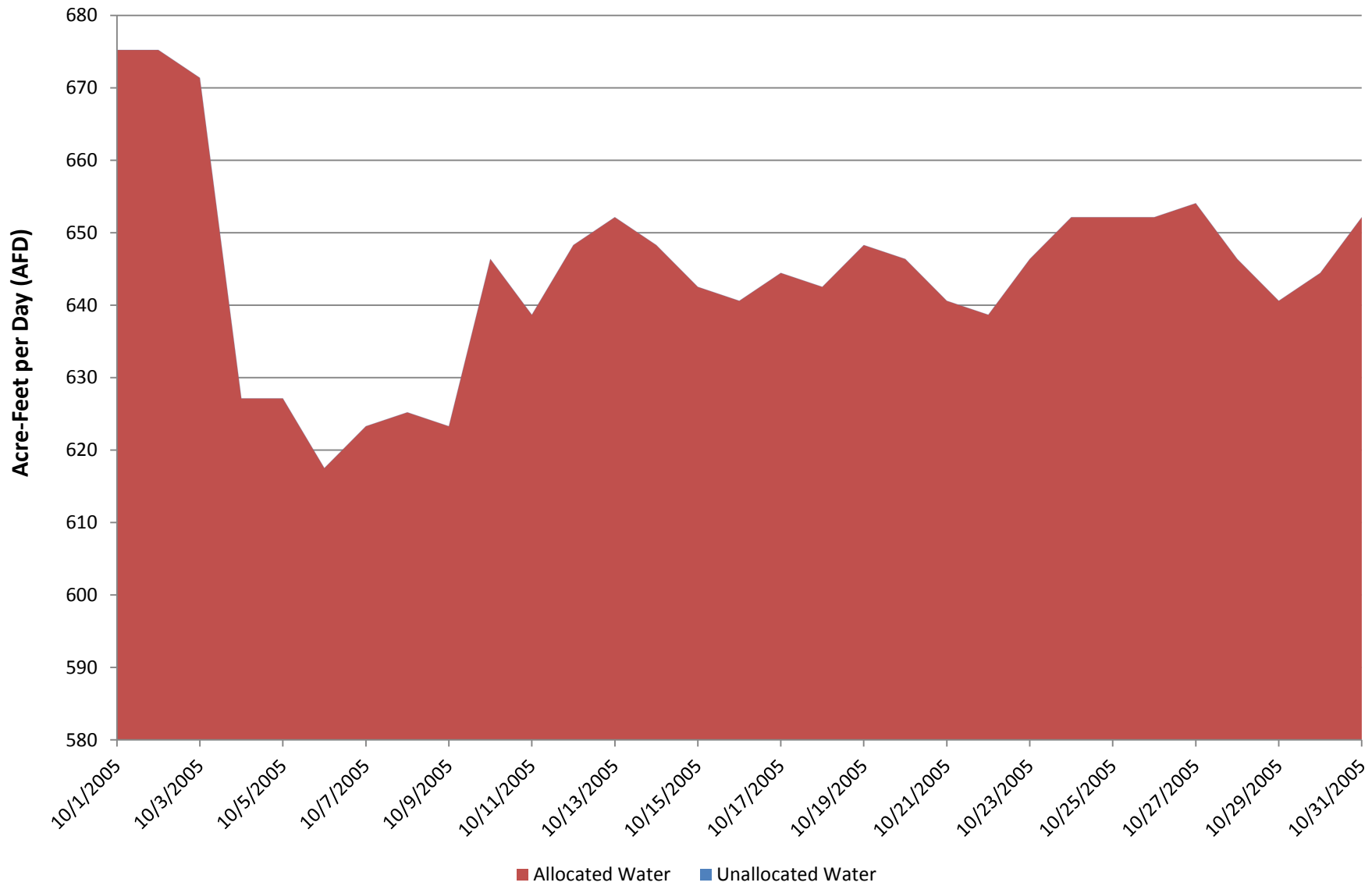
**Figure H-76: Daily Unallocated Water Calculation Downstream of Camanche Reservoir - August 2005 hydrology (2040 diversion assumptions)**



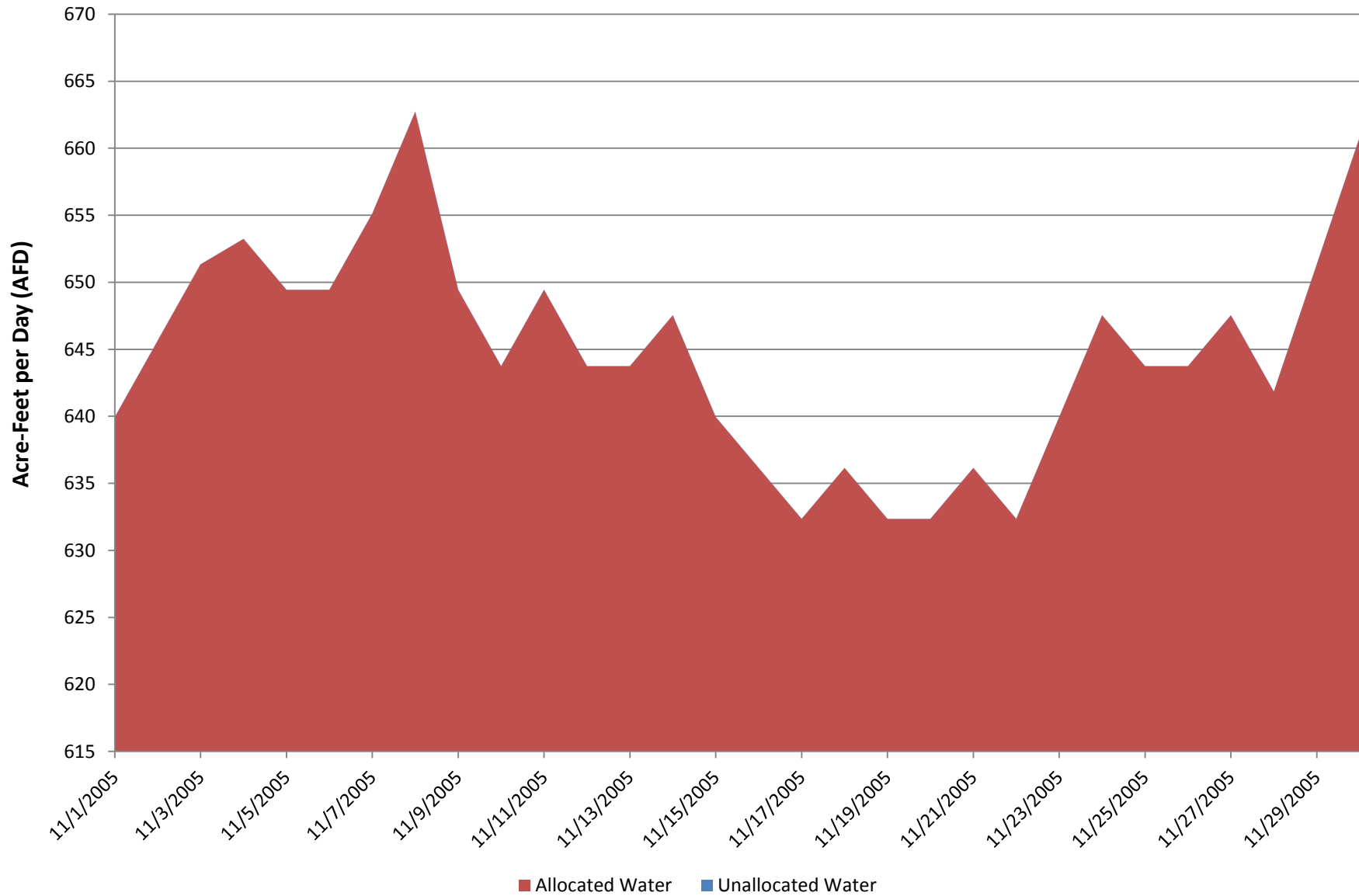
**Figure H-77: Daily Unallocated Water Calculation Downstream of Camanche Reservoir - September 2005 hydrology (2040 diversion assumptions)**



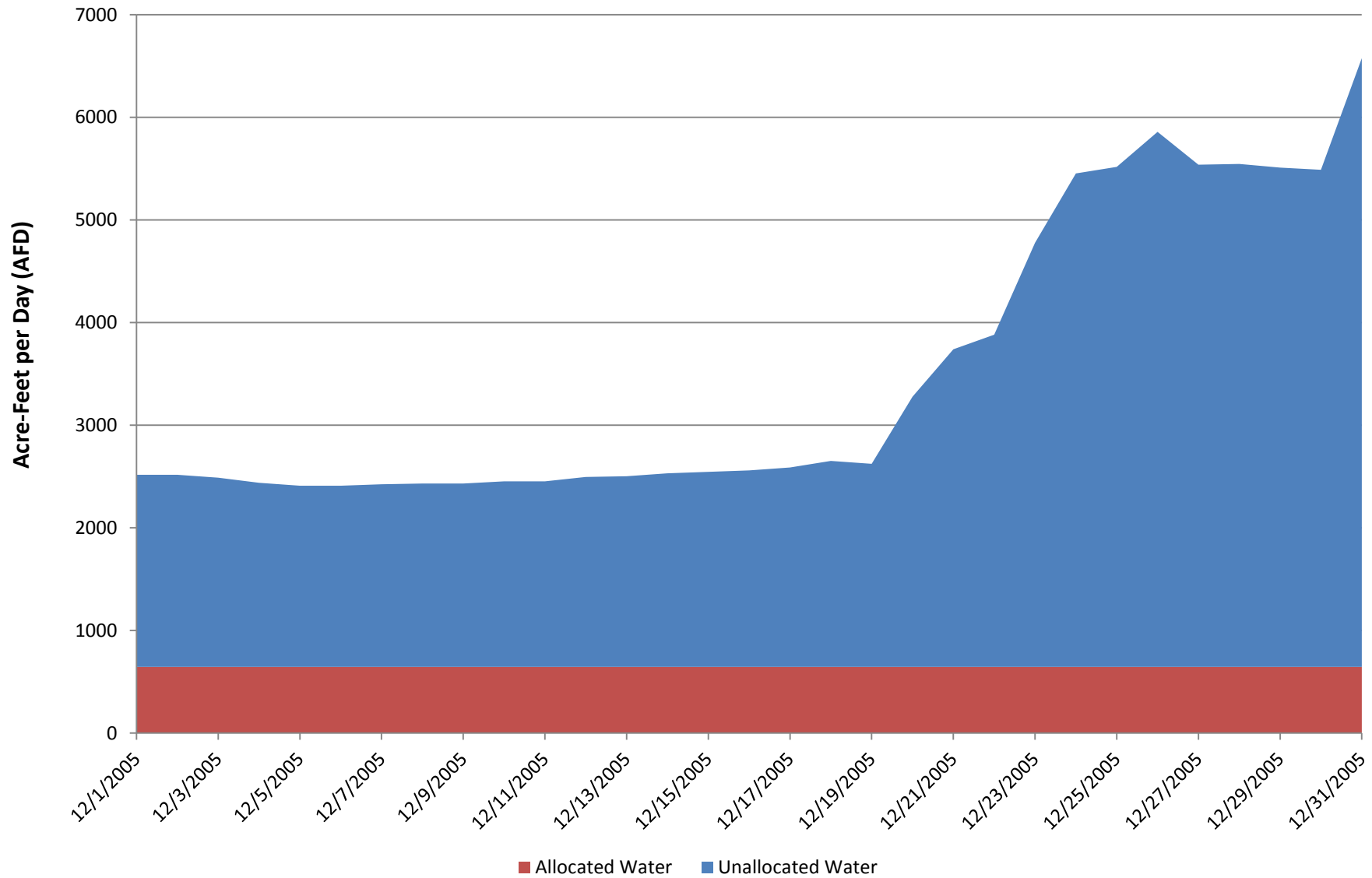
**Figure H-78: Daily Unallocated Water Calculation Downstream of Camanche Reservoir - October 2005 hydrology (2040 diversion assumptions)**



**Figure H-79: Daily Unallocated Water Calculation Downstream of Camanche Reservoir - November 2005 hydrology (2040 diversion assumptions)**

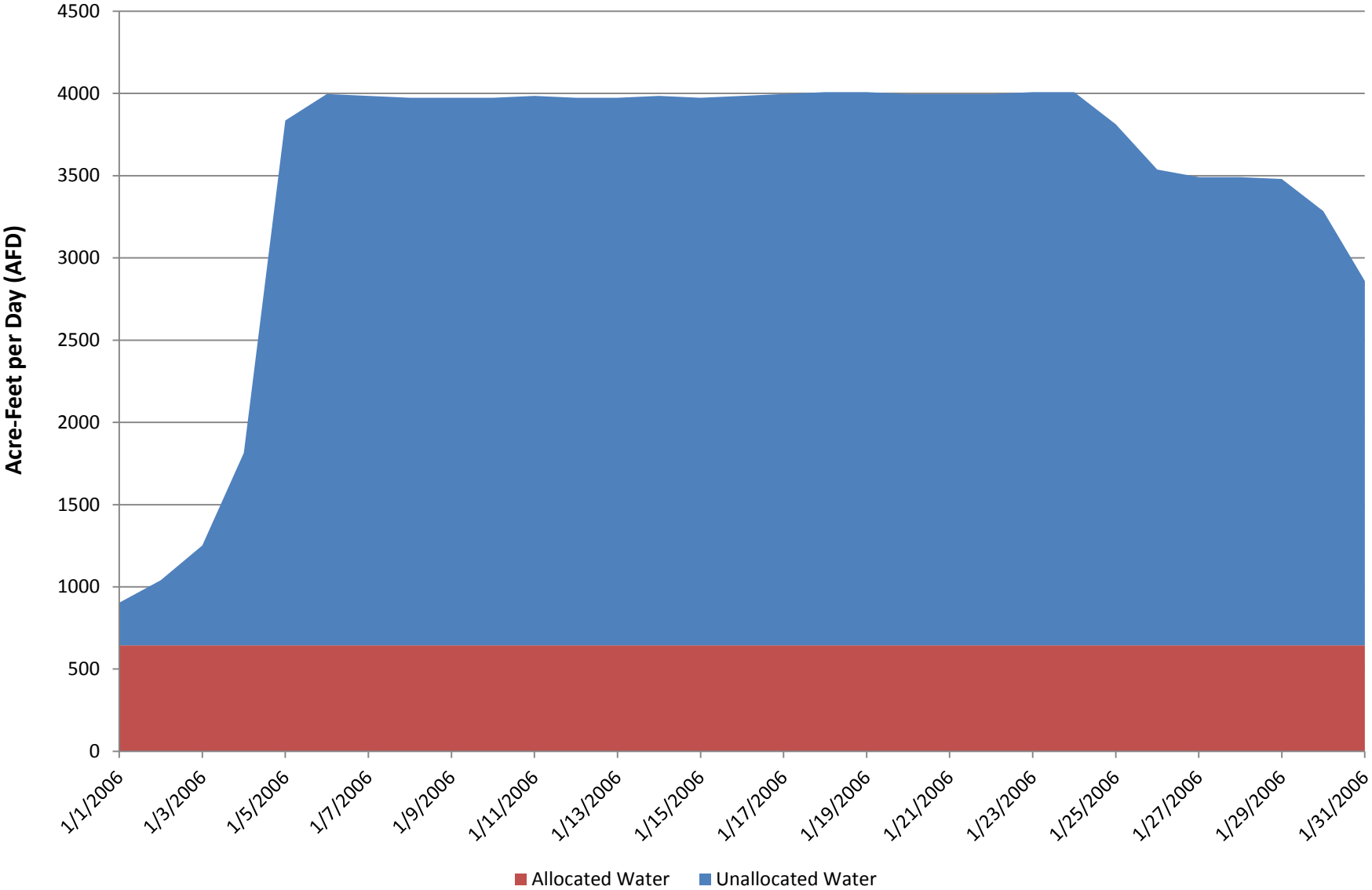


**Figure H-80: Daily Unallocated Water Calculation Downstream of Camanche Reservoir - December 2005 hydrology (2040 diversion assumptions)**





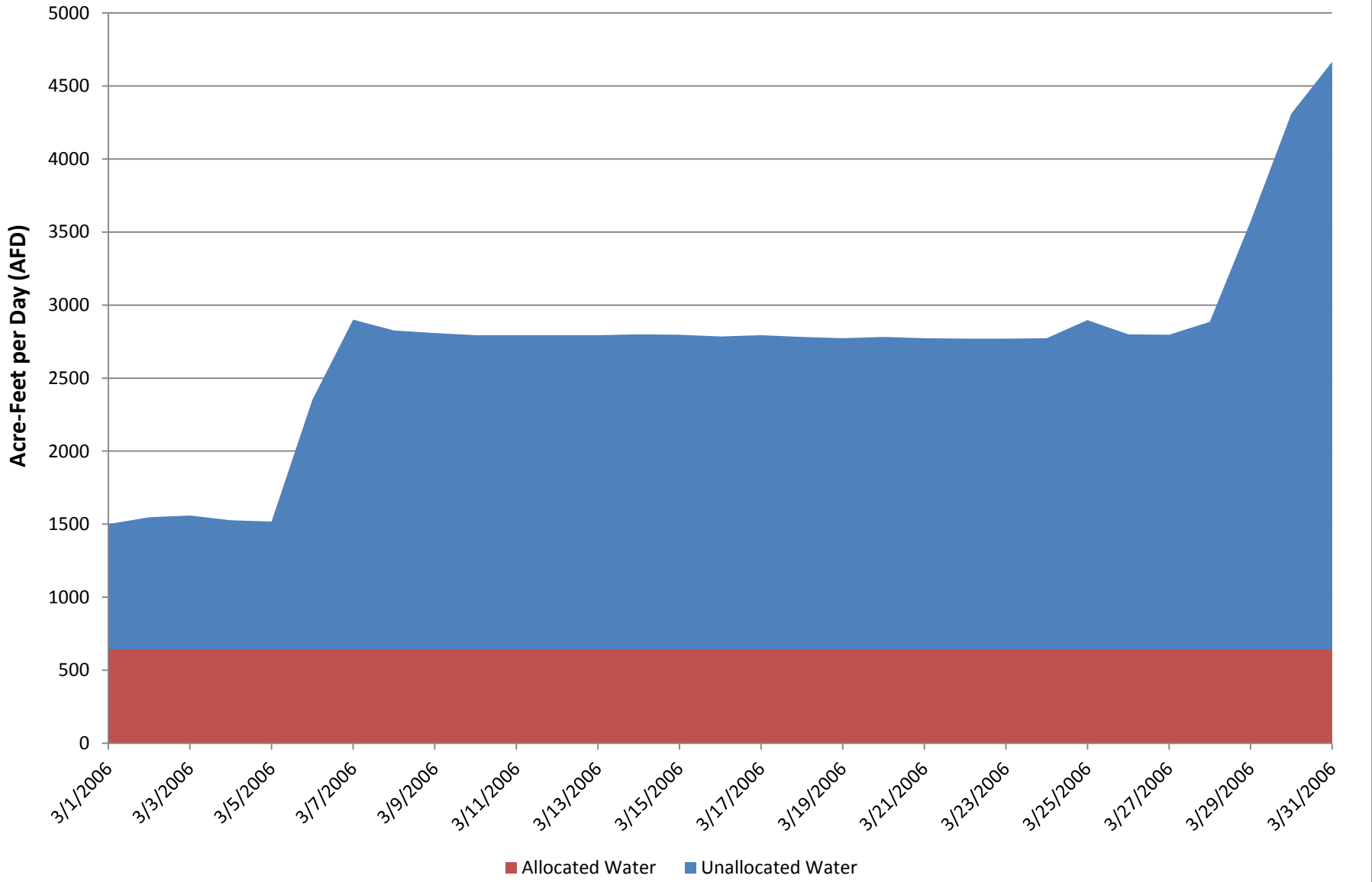
**Figure H-81: Daily Unallocated Water Calculation Downstream of Camanche Reservoir - January 2006 hydrology (2040 diversion assumptions)**



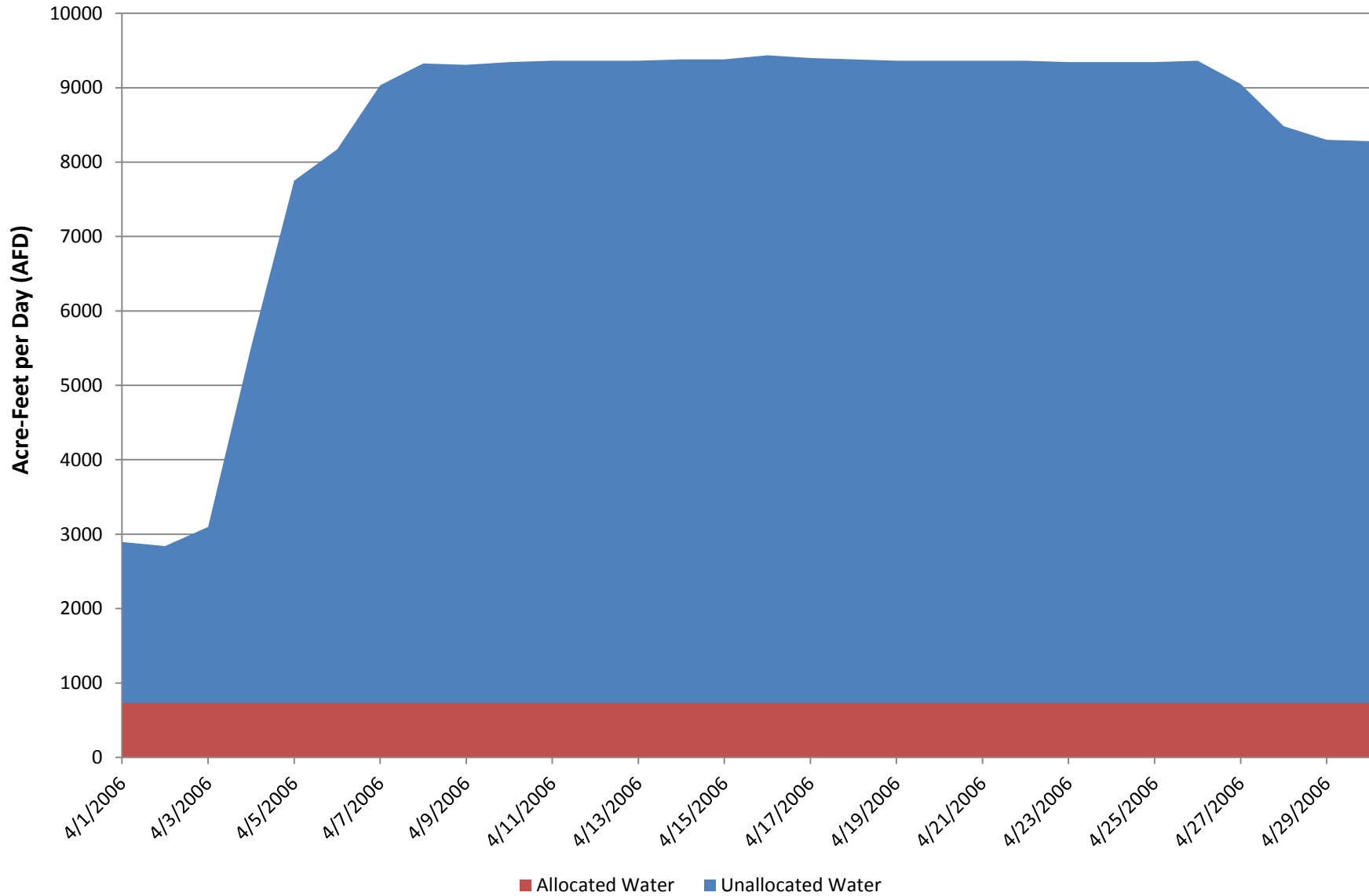
**Figure H-82: Daily Unallocated Water Calculation Downstream of Camanche Reservoir - February 2006 hydrology (2040 diversion assumptions)**



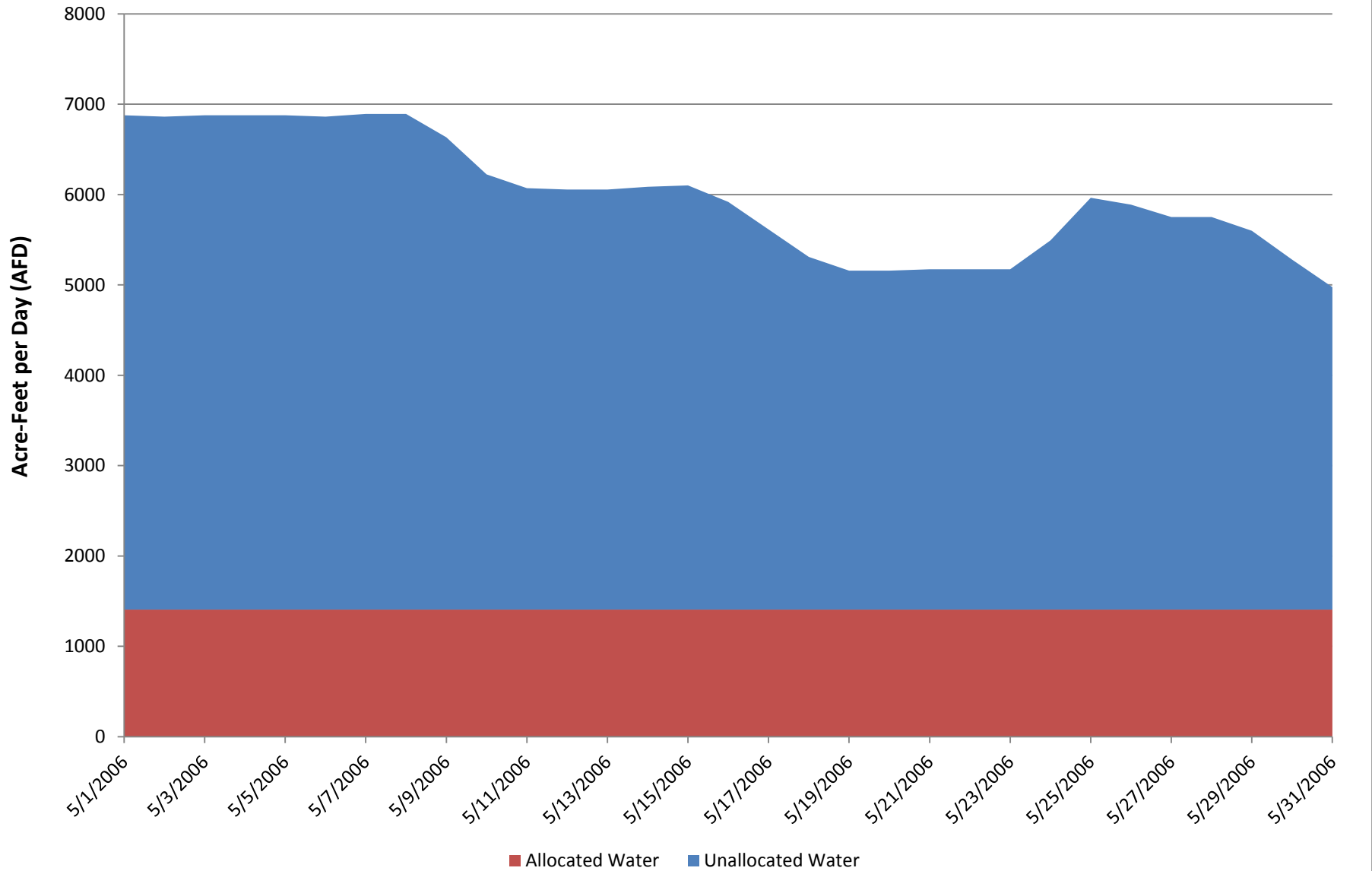
**Figure H-83: Daily Unallocated Water Calculation Downstream of Camanche Reservoir - March 2006 hydrology (2040 diversion assumptions)**



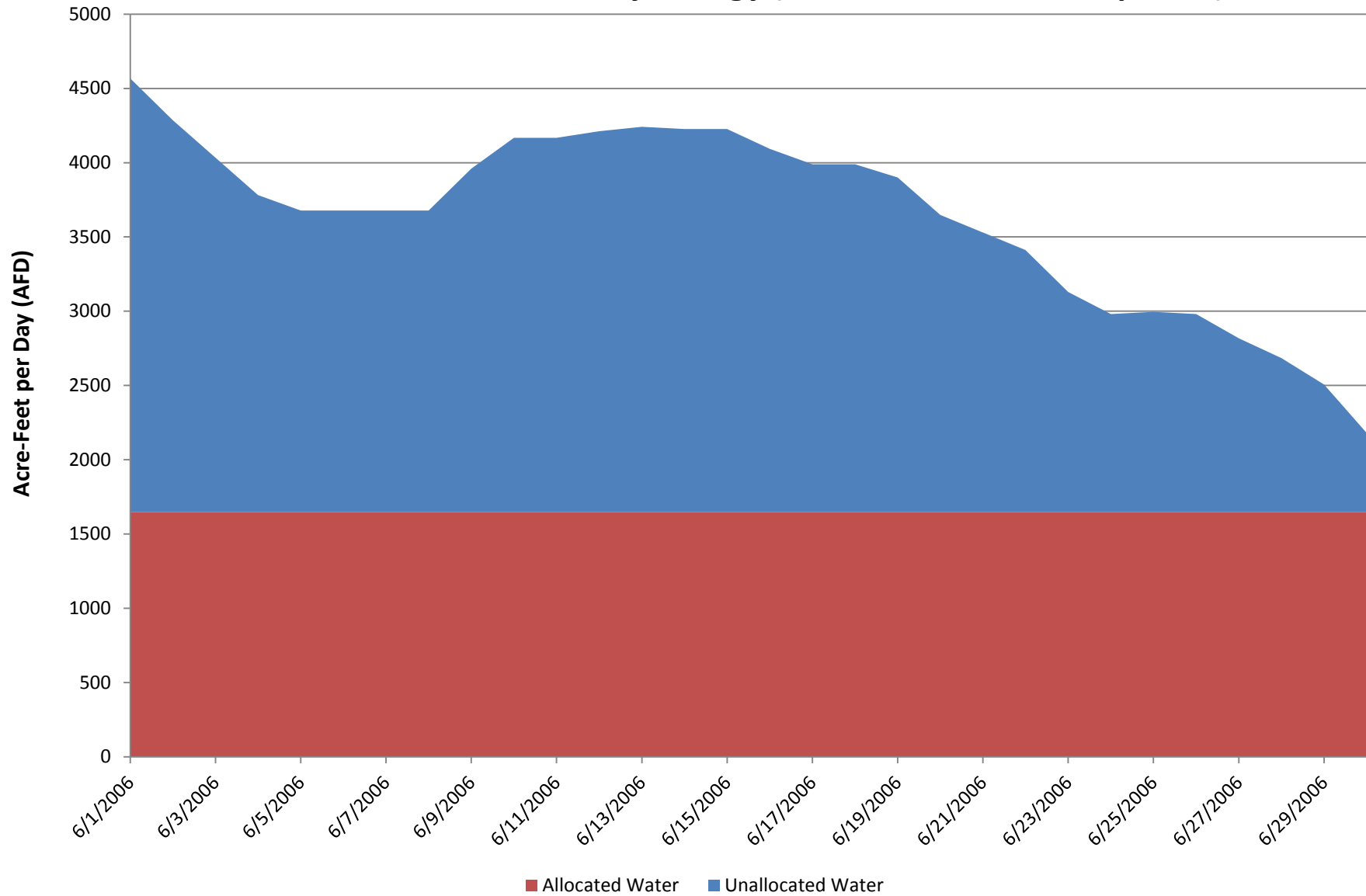
**Figure H-84: Daily Unallocated Water Calculation Downstream of Camanche Reservoir - April 2006 hydrology (2040 diversion assumptions)**



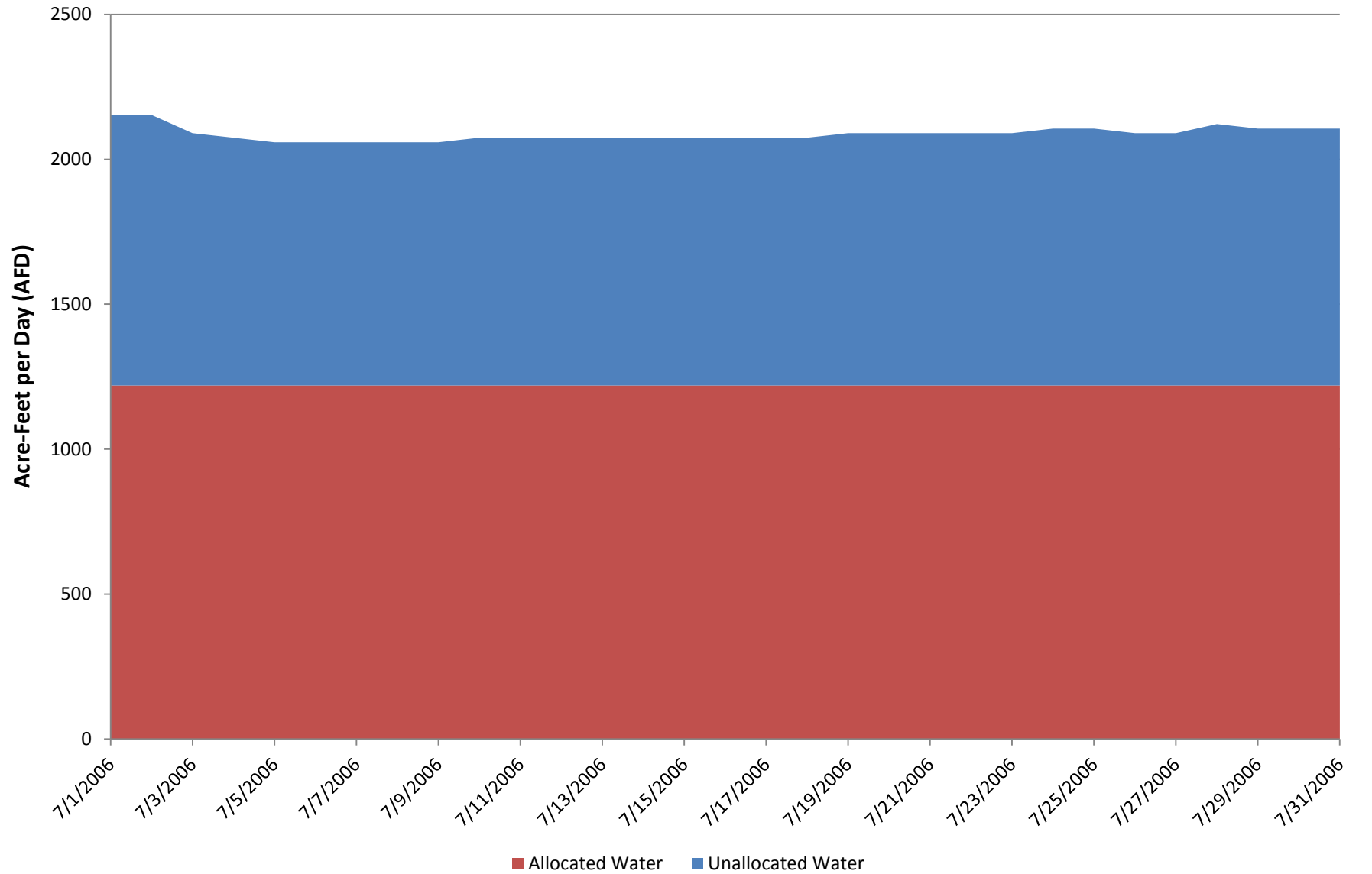
**Figure H-85: Daily Unallocated Water Calculation Downstream of Camanche Reservoir - May 2006 hydrology (2040 diversion assumptions)**



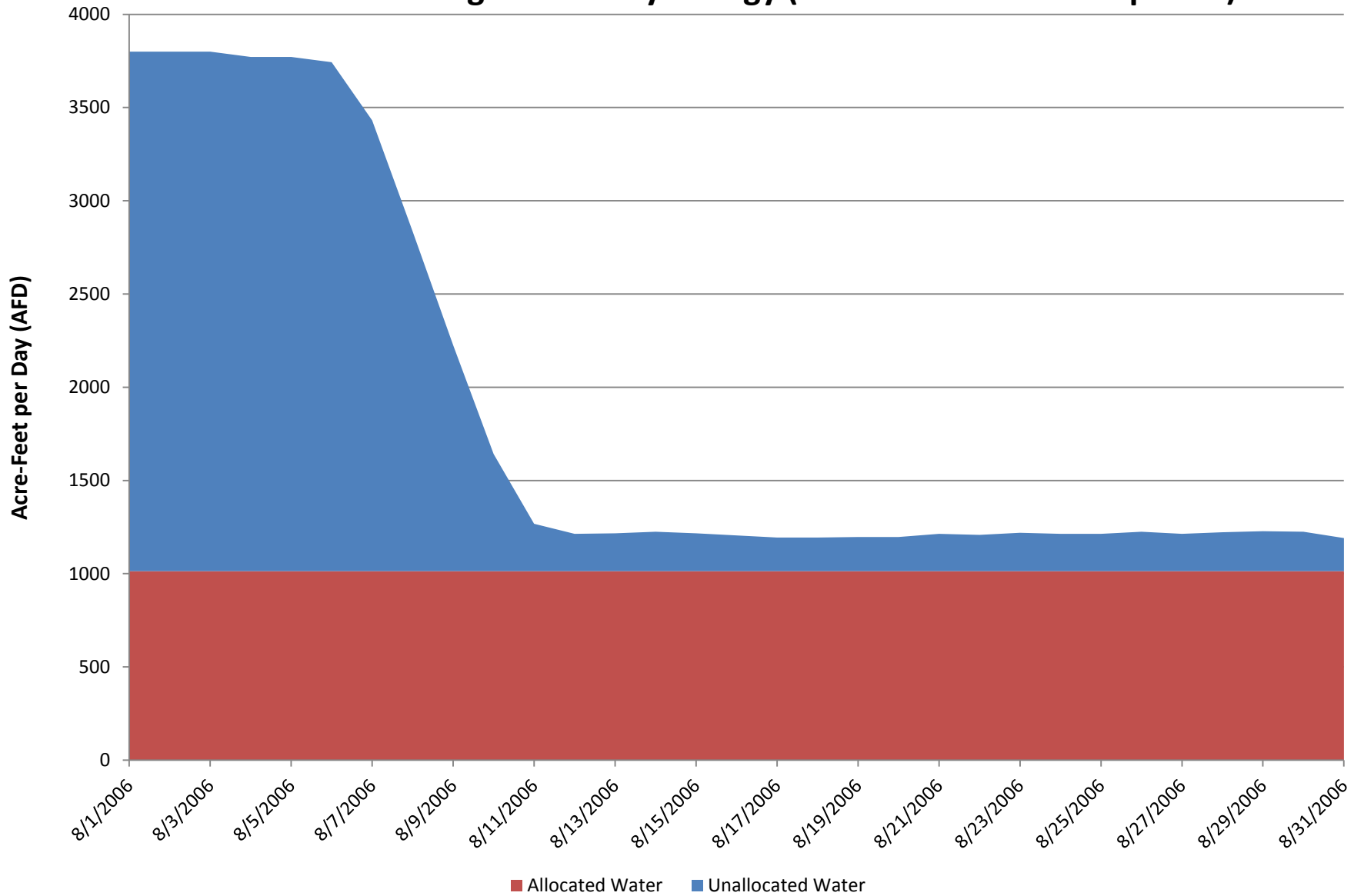
**Figure H-86: Daily Unallocated Water Calculation Downstream of Camanche Reservoir - June 2006 hydrology (2040 diversion assumptions)**



**Figure H-87: Daily Unallocated Water Calculation Downstream of Camanche Reservoir - July 2006 hydrology (2040 diversion assumptions)**

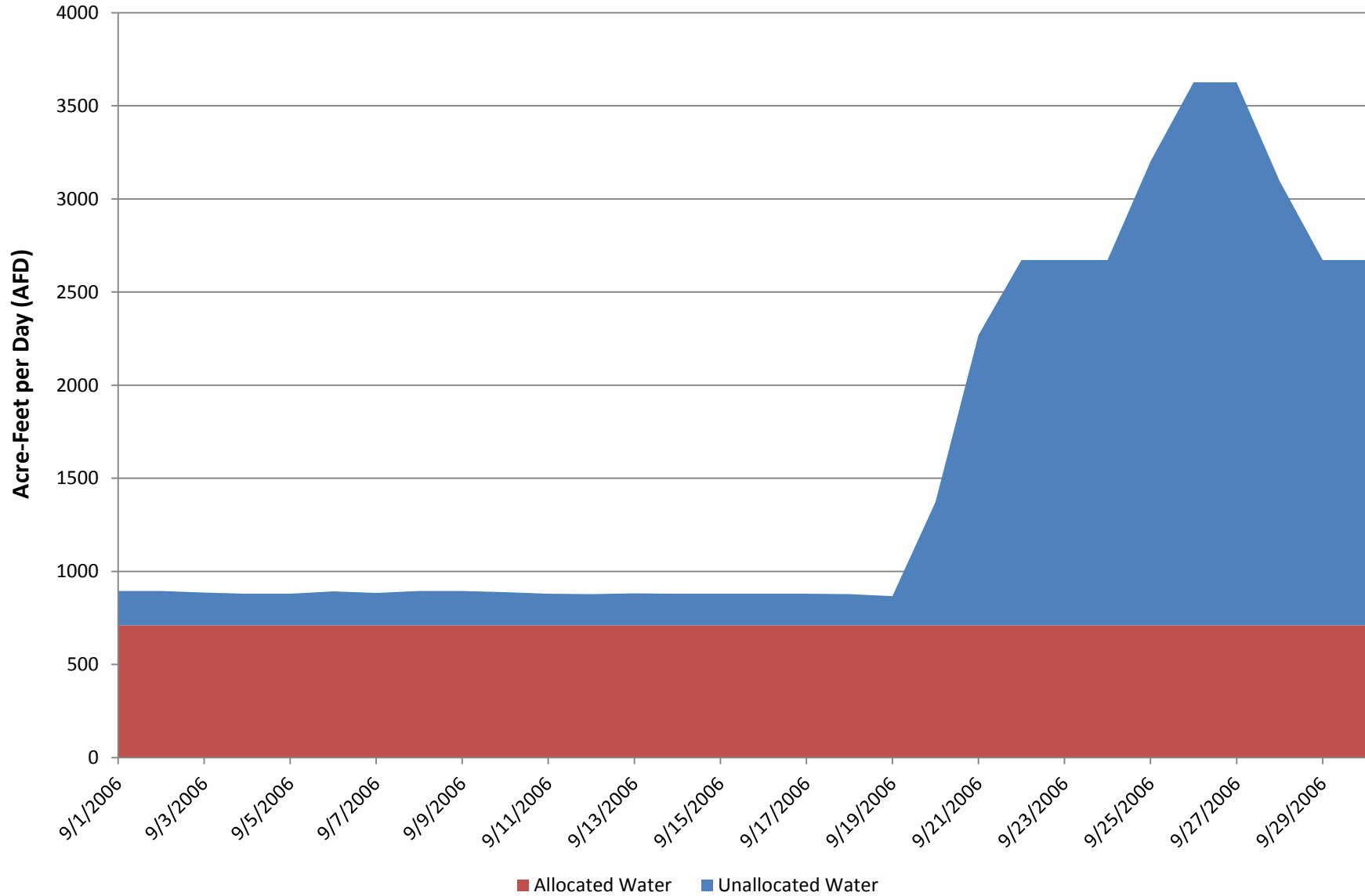


**Figure H-88: Daily Unallocated Water Calculation Downstream of Camanche Reservoir - August 2006 hydrology (2040 diversion assumptions)**

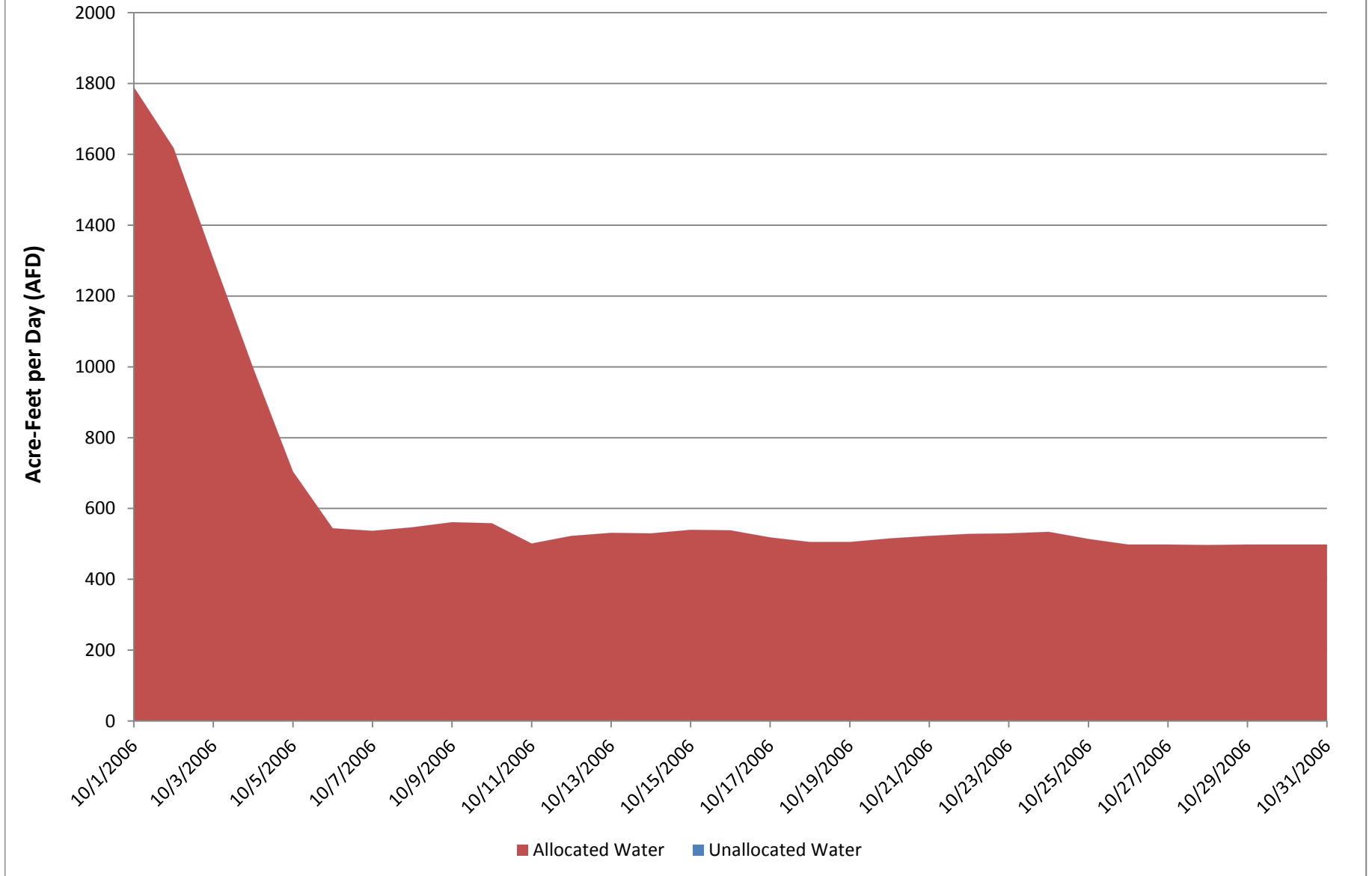




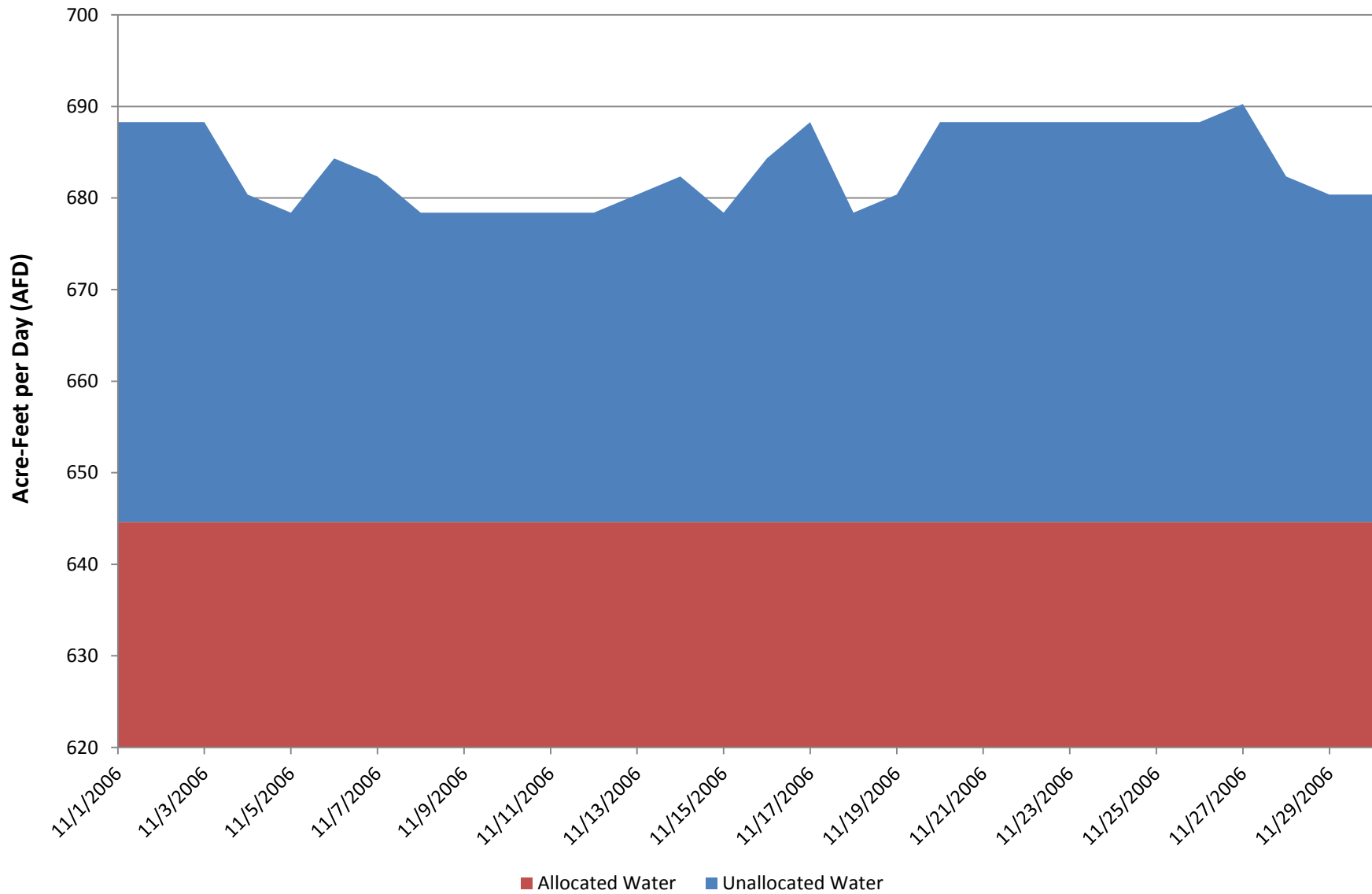
**Figure H-89: Daily Unallocated Water Calculation Downstream of Camanche Reservoir - September 2006 hydrology (2040 diversion assumptions)**



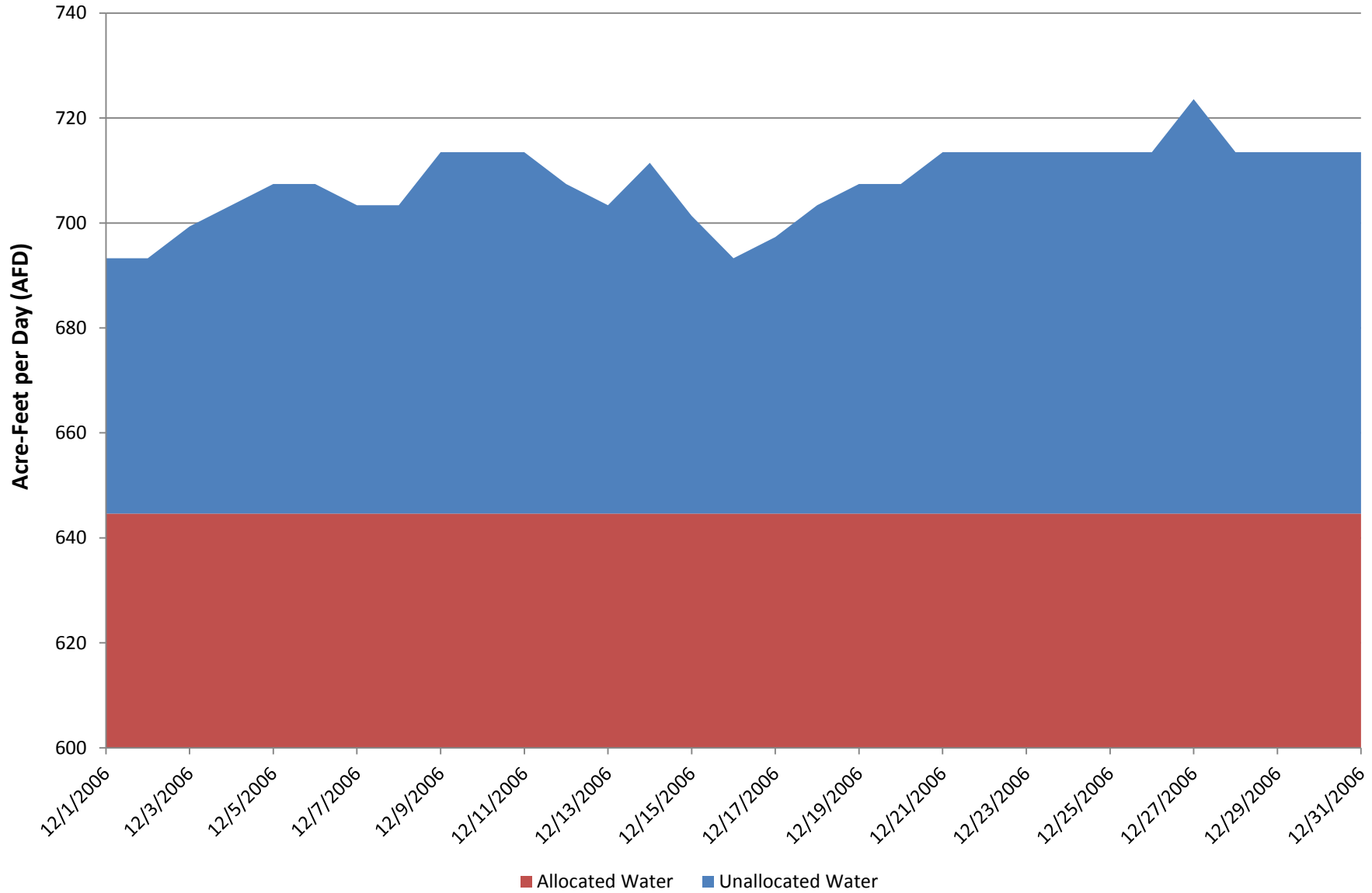
**Figure H-90: Daily Unallocated Water Calculation Downstream of Camanche Reservoir - October 2006 hydrology (2040 diversion assumptions)**



**Figure H-91: Daily Unallocated Water Calculation Downstream of Camanche Reservoir - November 2006 hydrology (2040 diversion assumptions)**



**Figure H-92: Daily Unallocated Water Calculation Downstream of Camanche Reservoir - December 2006 hydrology (2040 diversion assumptions)**



## **Appendix I: Riparian Diversions as Modeled in MOCASIM**

Appendix I shows the riparian diversions at Highway 99, Woodbridge Dam, and Interstate 5. Results indicate that diversions are greatest from May through July.

**Table I-1: Riparian Diversions Above Highway 99 (TAF)\***

	<b>Jan</b>	<b>Feb</b>	<b>Mar</b>	<b>Apr</b>	<b>May</b>	<b>Jun</b>	<b>Jul</b>	<b>Aug</b>	<b>Sep</b>	<b>Oct</b>	<b>Nov</b>	<b>Dec</b>	<b>Total</b>
<b>1953</b>	0.1	0.1	0.3	0.8	2.1	3.1	3.0	2.0	1.0	0.5	0.2	0.3	13.4
<b>1954</b>	0.1	0.1	0.3	0.8	2.1	3.1	3.0	2.0	1.0	0.5	0.2	0.3	13.4
<b>1955</b>	0.1	0.1	0.3	0.8	2.1	3.1	3.0	2.0	1.0	0.5	0.2	0.3	13.4
<b>1956</b>	0.1	0.1	0.3	0.8	2.1	3.1	3.0	2.0	1.0	0.5	0.2	0.3	13.4
<b>1957</b>	0.1	0.1	0.3	0.8	2.1	3.1	3.0	2.0	1.0	0.5	0.2	0.3	13.4
<b>1958</b>	0.1	0.1	0.3	0.8	2.1	3.1	3.0	2.0	1.0	0.5	0.2	0.3	13.4
<b>1959</b>	0.1	0.1	0.3	0.8	2.1	3.1	3.0	2.0	1.0	0.5	0.2	0.3	13.4
<b>1960</b>	0.1	0.1	0.3	0.8	2.1	3.1	3.0	2.0	1.0	0.5	0.2	0.3	13.4
<b>1961</b>	0.1	0.1	0.3	0.8	2.1	3.1	3.0	2.0	1.0	0.5	0.2	0.3	13.4
<b>1962</b>	0.1	0.1	0.3	0.8	2.1	3.1	3.0	2.0	1.0	0.5	0.2	0.3	13.4
<b>1963</b>	0.1	0.1	0.3	0.8	2.1	3.1	3.0	2.0	1.0	0.5	0.2	0.3	13.4
<b>1964</b>	0.1	0.1	0.3	0.8	2.1	3.1	3.0	2.0	1.0	0.5	0.2	0.3	13.4
<b>1965</b>	0.1	0.1	0.3	0.8	2.1	3.1	3.0	2.0	1.0	0.5	0.2	0.3	13.4
<b>1966</b>	0.1	0.1	0.3	0.8	2.1	3.1	3.0	2.0	1.0	0.5	0.2	0.3	13.4
<b>1967</b>	0.1	0.1	0.3	0.8	2.1	3.1	3.0	2.0	1.0	0.5	0.2	0.3	13.4
<b>1968</b>	0.1	0.1	0.3	0.8	2.1	3.1	3.0	2.0	1.0	0.5	0.2	0.3	13.4
<b>1969</b>	0.1	0.1	0.3	0.8	2.1	3.1	3.0	2.0	1.0	0.5	0.2	0.3	13.4
<b>1970</b>	0.1	0.1	0.3	0.8	2.1	3.1	3.0	2.0	1.0	0.5	0.2	0.3	13.4
<b>1971</b>	0.1	0.1	0.3	0.8	2.1	3.1	3.0	2.0	1.0	0.5	0.2	0.3	13.4
<b>1972</b>	0.1	0.1	0.3	0.8	2.1	3.1	3.0	2.0	1.0	0.5	0.2	0.3	13.4
<b>1973</b>	0.1	0.1	0.3	0.8	2.1	3.1	3.0	2.0	1.0	0.5	0.2	0.3	13.4
<b>1974</b>	0.1	0.1	0.3	0.8	2.1	3.1	3.0	2.0	1.0	0.5	0.2	0.3	13.4
<b>1975</b>	0.1	0.1	0.3	0.8	2.1	3.1	3.0	2.0	1.0	0.5	0.2	0.4	13.4
<b>1976</b>	0.1	0.1	0.3	0.8	2.1	3.1	1.5	1.0	0.5	0.5	0.2	0.4	10.4
<b>1977</b>	0.1	0.1	0.3	0.8	2.1	3.1	1.5	1.0	0.5	0.5	0.2	0.3	10.4
<b>1978</b>	0.1	0.1	0.3	0.8	2.1	3.1	3.0	2.0	1.0	0.5	0.2	0.3	13.4
<b>1979</b>	0.1	0.1	0.3	0.8	2.1	3.1	3.0	2.0	1.0	0.5	0.2	0.3	13.4
<b>1980</b>	0.1	0.1	0.3	0.8	2.1	3.1	3.0	2.0	1.0	0.5	0.2	0.3	13.4
<b>1981</b>	0.1	0.1	0.3	0.8	2.1	3.1	3.0	2.0	1.0	0.5	0.2	0.3	13.4
<b>1982</b>	0.1	0.1	0.3	0.8	2.1	3.1	3.0	2.0	1.0	0.5	0.2	0.3	13.4
<b>1983</b>	0.1	0.1	0.3	0.8	2.1	3.1	3.0	2.0	1.0	0.5	0.2	0.3	13.4
<b>1984</b>	0.1	0.1	0.3	0.8	2.1	3.1	3.0	2.0	1.0	0.5	0.2	0.3	13.4
<b>1985</b>	0.1	0.1	0.3	0.8	2.1	3.1	3.0	2.0	1.0	0.5	0.2	0.3	13.4
<b>1986</b>	0.1	0.1	0.3	0.8	2.1	3.1	3.0	2.0	1.0	0.5	0.2	0.3	13.4

**Table I-1: Riparian Diversions Above Highway 99 (TAF)\***

	<b>Jan</b>	<b>Feb</b>	<b>Mar</b>	<b>Apr</b>	<b>May</b>	<b>Jun</b>	<b>Jul</b>	<b>Aug</b>	<b>Sep</b>	<b>Oct</b>	<b>Nov</b>	<b>Dec</b>	<b>Total</b>
<b>1987</b>	0.1	0.1	0.3	0.8	2.1	3.1	3.0	2.0	1.0	0.5	0.2	0.4	13.4
<b>1988</b>	0.1	0.1	0.3	0.8	2.1	3.1	1.5	1.0	0.5	0.5	0.2	0.3	10.4
<b>1989</b>	0.1	0.1	0.3	0.8	2.1	3.1	3.0	2.0	1.0	0.5	0.2	0.3	13.4
<b>1990</b>	0.1	0.1	0.3	0.8	2.1	3.1	3.0	2.0	1.0	0.5	0.2	0.3	13.4
<b>1991</b>	0.1	0.1	0.3	0.8	2.1	3.1	3.0	2.0	1.0	0.5	0.2	0.3	13.4
<b>1992</b>	0.1	0.1	0.3	0.8	2.1	3.1	3.0	2.0	1.0	0.5	0.2	0.3	13.4
<b>1993</b>	0.1	0.1	0.3	0.8	2.1	3.1	3.0	2.0	1.0	0.5	0.2	0.3	13.4
<b>1994</b>	0.1	0.1	0.3	0.8	2.1	3.1	3.0	2.0	1.0	0.5	0.2	0.3	13.4
<b>1995</b>	0.1	0.1	0.3	0.8	2.1	3.1	3.0	2.0	1.0	0.5	0.2	0.3	13.4
<b>1996</b>	0.1	0.1	0.3	0.8	2.1	3.1	3.0	2.0	1.0	0.5	0.2	0.3	13.4
<b>1997</b>	0.1	0.1	0.3	0.8	2.1	3.1	3.0	2.0	1.0	0.5	0.2	0.3	13.4
<b>1998</b>	0.1	0.1	0.3	0.8	2.1	3.1	3.0	2.0	1.0	0.5	0.2	0.3	13.4
<b>1999</b>	0.1	0.1	0.3	0.8	2.1	3.1	3.0	2.0	1.0	0.5	0.2	0.3	13.4
<b>2000</b>	0.1	0.1	0.3	0.8	2.1	3.1	3.0	2.0	1.0	0.5	0.2	0.3	13.4
<b>2001</b>	0.1	0.1	0.3	0.8	2.1	3.1	3.0	2.0	1.0	0.5	0.2	0.3	13.4
<b>2002</b>	0.1	0.1	0.3	0.8	2.1	3.1	3.0	2.0	1.0	0.5	0.2	0.3	13.4
<b>2003</b>	0.1	0.1	0.3	0.8	2.1	3.1	3.0	2.0	1.0	0.5	0.2	0.3	13.4
<b>2004</b>	0.1	0.1	0.3	0.8	2.1	3.1	3.0	2.0	1.0	0.5	0.2	0.3	13.4
<b>2005</b>	0.1	0.1	0.3	0.8	2.1	3.1	3.0	2.0	1.0	0.5	0.2	0.3	13.4
<b>2006</b>	0.1	0.1	0.3	0.8	2.1	3.1	3.0	2.0	1.0	0.5	0.2	0.3	13.4
<b>2007</b>	0.1	0.1	0.3	0.8	2.1	3.1	3.0	2.0	1.0	0.5	0.2	0.3	13.4
<b>2008</b>	0.1	0.1	0.3	0.8	2.1	3.1	3.0	2.0	1.0	0.5	0.2	0.3	13.4
<b>2009</b>	0.1	0.1	0.3	0.8	2.1	3.1	3.0	2.0	1.0	0.5	0.2	0.3	13.4
<b>2010</b>	0.1	0.1	0.3	0.8	2.1	3.1	3.0	2.0	1.0	0.5	0.2	0.4	13.4
<b>Ave</b>	0.1	0.1	0.3	0.8	2.1	3.1	2.9	1.9	0.9	0.5	0.2	0.3	13.2
<b>Max</b>	0.1	0.1	0.3	0.8	2.1	3.1	3.0	2.0	1.0	0.5	0.2	0.4	13.4
<b>Min</b>	0.1	0.1	0.3	0.8	2.1	3.1	1.5	1.0	0.5	0.5	0.2	0.3	10.4

\*Note: Riparian diversions are the same for both the 2010 and 2040 baseline cases.

**Table I-2: Riparian Diversions Above Woodbridge Diversion Dam (TAF)\***

	<b>Jan</b>	<b>Feb</b>	<b>Mar</b>	<b>Apr</b>	<b>May</b>	<b>Jun</b>	<b>Jul</b>	<b>Aug</b>	<b>Sep</b>	<b>Oct</b>	<b>Nov</b>	<b>Dec</b>	<b>Total</b>
<b>1953</b>	0.0	0.0	0.0	0.1	0.2	0.2	0.2	0.2	0.1	0.0	0.0	0.0	1.0
<b>1954</b>	0.0	0.0	0.0	0.1	0.2	0.2	0.2	0.2	0.1	0.0	0.0	0.0	1.0
<b>1955</b>	0.0	0.0	0.0	0.1	0.2	0.2	0.2	0.2	0.1	0.0	0.0	0.0	1.0
<b>1956</b>	0.0	0.0	0.0	0.1	0.2	0.2	0.2	0.2	0.1	0.0	0.0	0.0	1.0
<b>1957</b>	0.0	0.0	0.0	0.1	0.2	0.2	0.2	0.2	0.1	0.0	0.0	0.0	1.0
<b>1958</b>	0.0	0.0	0.0	0.1	0.2	0.2	0.2	0.2	0.1	0.0	0.0	0.0	1.0
<b>1959</b>	0.0	0.0	0.0	0.1	0.2	0.2	0.2	0.2	0.1	0.0	0.0	0.0	1.0
<b>1960</b>	0.0	0.0	0.0	0.1	0.2	0.2	0.2	0.2	0.1	0.0	0.0	0.0	1.0
<b>1961</b>	0.0	0.0	0.0	0.1	0.2	0.2	0.2	0.2	0.1	0.0	0.0	0.0	1.0
<b>1962</b>	0.0	0.0	0.0	0.1	0.2	0.2	0.2	0.2	0.1	0.0	0.0	0.0	1.0
<b>1963</b>	0.0	0.0	0.0	0.1	0.2	0.2	0.2	0.2	0.1	0.0	0.0	0.0	1.0
<b>1964</b>	0.0	0.0	0.0	0.1	0.2	0.2	0.2	0.2	0.1	0.0	0.0	0.0	1.0
<b>1965</b>	0.0	0.0	0.0	0.1	0.2	0.2	0.2	0.2	0.1	0.0	0.0	0.0	1.0
<b>1966</b>	0.0	0.0	0.0	0.1	0.2	0.2	0.2	0.2	0.1	0.0	0.0	0.0	1.0
<b>1967</b>	0.0	0.0	0.0	0.1	0.2	0.2	0.2	0.2	0.1	0.0	0.0	0.0	1.0
<b>1968</b>	0.0	0.0	0.0	0.1	0.2	0.2	0.2	0.2	0.1	0.0	0.0	0.0	1.0
<b>1969</b>	0.0	0.0	0.0	0.1	0.2	0.2	0.2	0.2	0.1	0.0	0.0	0.0	1.0
<b>1970</b>	0.0	0.0	0.0	0.1	0.2	0.2	0.2	0.2	0.1	0.0	0.0	0.0	1.0
<b>1971</b>	0.0	0.0	0.0	0.1	0.2	0.2	0.2	0.2	0.1	0.0	0.0	0.0	1.0
<b>1972</b>	0.0	0.0	0.0	0.1	0.2	0.2	0.2	0.2	0.1	0.0	0.0	0.0	1.0
<b>1973</b>	0.0	0.0	0.0	0.1	0.2	0.2	0.2	0.2	0.1	0.0	0.0	0.0	1.0
<b>1974</b>	0.0	0.0	0.0	0.1	0.2	0.2	0.2	0.2	0.1	0.0	0.0	0.0	1.0
<b>1975</b>	0.0	0.0	0.0	0.1	0.2	0.2	0.2	0.2	0.1	0.0	0.0	0.0	1.0
<b>1976</b>	0.0	0.0	0.0	0.1	0.2	0.2	0.1	0.1	0.0	0.0	0.0	0.0	0.8
<b>1977</b>	0.0	0.0	0.0	0.1	0.2	0.2	0.1	0.1	0.0	0.0	0.0	0.0	0.8
<b>1978</b>	0.0	0.0	0.0	0.1	0.2	0.2	0.2	0.2	0.1	0.0	0.0	0.0	1.0
<b>1979</b>	0.0	0.0	0.0	0.1	0.2	0.2	0.2	0.2	0.1	0.0	0.0	0.0	1.0
<b>1980</b>	0.0	0.0	0.0	0.1	0.2	0.2	0.2	0.2	0.1	0.0	0.0	0.0	1.0
<b>1981</b>	0.0	0.0	0.0	0.1	0.2	0.2	0.2	0.2	0.1	0.0	0.0	0.0	1.0
<b>1982</b>	0.0	0.0	0.0	0.1	0.2	0.2	0.2	0.2	0.1	0.0	0.0	0.0	1.0
<b>1983</b>	0.0	0.0	0.0	0.1	0.2	0.2	0.2	0.2	0.1	0.0	0.0	0.0	1.0
<b>1984</b>	0.0	0.0	0.0	0.1	0.2	0.2	0.2	0.2	0.1	0.0	0.0	0.0	1.0
<b>1985</b>	0.0	0.0	0.0	0.1	0.2	0.2	0.2	0.2	0.1	0.0	0.0	0.0	1.0
<b>1986</b>	0.0	0.0	0.0	0.1	0.2	0.2	0.2	0.2	0.1	0.0	0.0	0.0	1.0



**Table I-2: Riparian Diversions Above Woodbridge Diversion Dam (TAF)\***

	<b>Jan</b>	<b>Feb</b>	<b>Mar</b>	<b>Apr</b>	<b>May</b>	<b>Jun</b>	<b>Jul</b>	<b>Aug</b>	<b>Sep</b>	<b>Oct</b>	<b>Nov</b>	<b>Dec</b>	<b>Total</b>
<b>1987</b>	0.0	0.0	0.0	0.1	0.2	0.2	0.2	0.2	0.1	0.0	0.0	0.0	1.0
<b>1988</b>	0.0	0.0	0.0	0.1	0.2	0.2	0.1	0.1	0.0	0.0	0.0	0.0	0.8
<b>1989</b>	0.0	0.0	0.0	0.1	0.2	0.2	0.2	0.2	0.1	0.0	0.0	0.0	1.0
<b>1990</b>	0.0	0.0	0.0	0.1	0.2	0.2	0.2	0.2	0.1	0.0	0.0	0.0	1.0
<b>1991</b>	0.0	0.0	0.0	0.1	0.2	0.2	0.2	0.2	0.1	0.0	0.0	0.0	1.0
<b>1992</b>	0.0	0.0	0.0	0.1	0.2	0.2	0.2	0.2	0.1	0.0	0.0	0.0	1.0
<b>1993</b>	0.0	0.0	0.0	0.1	0.2	0.2	0.2	0.2	0.1	0.0	0.0	0.0	1.0
<b>1994</b>	0.0	0.0	0.0	0.1	0.2	0.2	0.2	0.2	0.1	0.0	0.0	0.0	1.0
<b>1995</b>	0.0	0.0	0.0	0.1	0.2	0.2	0.2	0.2	0.1	0.0	0.0	0.0	1.0
<b>1996</b>	0.0	0.0	0.0	0.1	0.2	0.2	0.2	0.2	0.1	0.0	0.0	0.0	1.0
<b>1997</b>	0.0	0.0	0.0	0.1	0.2	0.2	0.2	0.2	0.1	0.0	0.0	0.0	1.0
<b>1998</b>	0.0	0.0	0.0	0.1	0.2	0.2	0.2	0.2	0.1	0.0	0.0	0.0	1.0
<b>1999</b>	0.0	0.0	0.0	0.1	0.2	0.2	0.2	0.2	0.1	0.0	0.0	0.0	1.0
<b>2000</b>	0.0	0.0	0.0	0.1	0.2	0.2	0.2	0.2	0.1	0.0	0.0	0.0	1.0
<b>2001</b>	0.0	0.0	0.0	0.1	0.2	0.2	0.2	0.2	0.1	0.0	0.0	0.0	1.0
<b>2002</b>	0.0	0.0	0.0	0.1	0.2	0.2	0.2	0.2	0.1	0.0	0.0	0.0	1.0
<b>2003</b>	0.0	0.0	0.0	0.1	0.2	0.2	0.2	0.2	0.1	0.0	0.0	0.0	1.0
<b>2004</b>	0.0	0.0	0.0	0.1	0.2	0.2	0.2	0.2	0.1	0.0	0.0	0.0	1.0
<b>2005</b>	0.0	0.0	0.0	0.1	0.2	0.2	0.2	0.2	0.1	0.0	0.0	0.0	1.0
<b>2006</b>	0.0	0.0	0.0	0.1	0.2	0.2	0.2	0.2	0.1	0.0	0.0	0.0	1.0
<b>2007</b>	0.0	0.0	0.0	0.1	0.2	0.2	0.2	0.2	0.1	0.0	0.0	0.0	1.0
<b>2008</b>	0.0	0.0	0.0	0.1	0.2	0.2	0.2	0.2	0.1	0.0	0.0	0.0	1.0
<b>2009</b>	0.0	0.0	0.0	0.1	0.2	0.2	0.2	0.2	0.1	0.0	0.0	0.0	1.0
<b>2010</b>	0.0	0.0	0.0	0.1	0.2	0.2	0.2	0.2	0.1	0.0	0.0	0.0	1.0
<b>Ave</b>	0.0	0.0	0.0	0.1	0.2	0.2	0.2	0.1	0.1	0.0	0.0	0.0	1.0
<b>Max</b>	0.0	0.0	0.0	0.1	0.2	0.2	0.2	0.2	0.1	0.0	0.0	0.0	1.0
<b>Min</b>	0.0	0.0	0.0	0.1	0.2	0.2	0.1	0.1	0.0	0.0	0.0	0.0	0.8

\*Note: Riparian diversions are the same for both the 2010 and 2040 baseline cases.

**Table I-3: Riparian Diversions Above Interstate 5 (TAF)\***

	<b>Jan</b>	<b>Feb</b>	<b>Mar</b>	<b>Apr</b>	<b>May</b>	<b>Jun</b>	<b>Jul</b>	<b>Aug</b>	<b>Sep</b>	<b>Oct</b>	<b>Nov</b>	<b>Dec</b>	<b>Total</b>
<b>1953</b>	0.0	0.0	0.1	0.4	1.0	1.4	1.4	0.9	0.4	0.2	0.1	0.2	6.2
<b>1954</b>	0.0	0.0	0.1	0.4	1.0	1.4	1.4	0.9	0.4	0.2	0.1	0.2	6.2
<b>1955</b>	0.0	0.0	0.1	0.4	1.0	1.4	1.4	0.9	0.4	0.2	0.1	0.2	6.2
<b>1956</b>	0.0	0.0	0.1	0.4	1.0	1.4	1.4	0.9	0.4	0.2	0.1	0.2	6.2
<b>1957</b>	0.0	0.0	0.1	0.4	1.0	1.4	1.4	0.9	0.4	0.2	0.1	0.2	6.2
<b>1958</b>	0.0	0.0	0.1	0.4	1.0	1.4	1.4	0.9	0.4	0.2	0.1	0.2	6.2
<b>1959</b>	0.0	0.0	0.1	0.4	1.0	1.4	1.4	0.9	0.4	0.2	0.1	0.2	6.2
<b>1960</b>	0.0	0.0	0.1	0.4	1.0	1.4	1.4	0.9	0.4	0.2	0.1	0.2	6.2
<b>1961</b>	0.0	0.0	0.1	0.4	1.0	1.4	1.4	0.9	0.4	0.2	0.1	0.2	6.2
<b>1962</b>	0.0	0.0	0.1	0.4	1.0	1.4	1.4	0.9	0.4	0.2	0.1	0.2	6.2
<b>1963</b>	0.0	0.0	0.1	0.4	1.0	1.4	1.4	0.9	0.4	0.2	0.1	0.2	6.2
<b>1964</b>	0.0	0.0	0.1	0.4	1.0	1.4	1.4	0.9	0.4	0.2	0.1	0.2	6.2
<b>1965</b>	0.0	0.0	0.1	0.4	1.0	1.4	1.4	0.9	0.4	0.2	0.1	0.2	6.2
<b>1966</b>	0.0	0.0	0.1	0.4	1.0	1.4	1.4	0.9	0.4	0.2	0.1	0.2	6.2
<b>1967</b>	0.0	0.0	0.1	0.4	1.0	1.4	1.4	0.9	0.4	0.2	0.1	0.2	6.2
<b>1968</b>	0.0	0.0	0.1	0.4	1.0	1.4	1.4	0.9	0.4	0.2	0.1	0.2	6.2
<b>1969</b>	0.0	0.0	0.1	0.4	1.0	1.4	1.4	0.9	0.4	0.2	0.1	0.2	6.2
<b>1970</b>	0.0	0.0	0.1	0.4	1.0	1.4	1.4	0.9	0.4	0.2	0.1	0.2	6.2
<b>1971</b>	0.0	0.0	0.1	0.4	1.0	1.4	1.4	0.9	0.4	0.2	0.1	0.2	6.2
<b>1972</b>	0.0	0.0	0.1	0.4	1.0	1.4	1.4	0.9	0.4	0.2	0.1	0.2	6.2
<b>1973</b>	0.0	0.0	0.1	0.4	1.0	1.4	1.4	0.9	0.4	0.2	0.1	0.2	6.2
<b>1974</b>	0.0	0.0	0.1	0.4	1.0	1.4	1.4	0.9	0.4	0.2	0.1	0.2	6.2
<b>1975</b>	0.0	0.0	0.1	0.4	1.0	1.4	1.4	0.9	0.4	0.2	0.1	0.2	6.2
<b>1976</b>	0.0	0.0	0.1	0.4	1.0	1.4	0.7	0.4	0.2	0.2	0.1	0.2	4.8
<b>1977</b>	0.0	0.0	0.1	0.4	1.0	1.4	0.7	0.4	0.2	0.2	0.1	0.2	4.8
<b>1978</b>	0.0	0.0	0.1	0.4	1.0	1.4	1.4	0.9	0.4	0.2	0.1	0.2	6.2
<b>1979</b>	0.0	0.0	0.1	0.4	1.0	1.4	1.4	0.9	0.4	0.2	0.1	0.2	6.2
<b>1980</b>	0.0	0.0	0.1	0.4	1.0	1.4	1.4	0.9	0.4	0.2	0.1	0.2	6.2
<b>1981</b>	0.0	0.0	0.1	0.4	1.0	1.4	1.4	0.9	0.4	0.2	0.1	0.2	6.2
<b>1982</b>	0.0	0.0	0.1	0.4	1.0	1.4	1.4	0.9	0.4	0.2	0.1	0.2	6.2
<b>1983</b>	0.0	0.0	0.1	0.4	1.0	1.4	1.4	0.9	0.4	0.2	0.1	0.2	6.2
<b>1984</b>	0.0	0.0	0.1	0.4	1.0	1.4	1.4	0.9	0.4	0.2	0.1	0.2	6.2
<b>1985</b>	0.0	0.0	0.1	0.4	1.0	1.4	1.4	0.9	0.4	0.2	0.1	0.2	6.2
<b>1986</b>	0.0	0.0	0.1	0.4	1.0	1.4	1.4	0.9	0.4	0.2	0.1	0.2	6.2

**Table I-3: Riparian Diversions Above Interstate 5 (TAF)\***

	<b>Jan</b>	<b>Feb</b>	<b>Mar</b>	<b>Apr</b>	<b>May</b>	<b>Jun</b>	<b>Jul</b>	<b>Aug</b>	<b>Sep</b>	<b>Oct</b>	<b>Nov</b>	<b>Dec</b>	<b>Total</b>
<b>1987</b>	0.0	0.0	0.1	0.4	1.0	1.4	1.4	0.9	0.4	0.2	0.1	0.2	6.2
<b>1988</b>	0.0	0.0	0.1	0.4	1.0	1.4	0.7	0.4	0.2	0.2	0.1	0.2	4.8
<b>1989</b>	0.0	0.0	0.1	0.4	1.0	1.4	1.4	0.9	0.4	0.2	0.1	0.2	6.2
<b>1990</b>	0.0	0.0	0.1	0.4	1.0	1.4	1.4	0.9	0.4	0.2	0.1	0.2	6.2
<b>1991</b>	0.0	0.0	0.1	0.4	1.0	1.4	1.4	0.9	0.4	0.2	0.1	0.2	6.2
<b>1992</b>	0.0	0.0	0.1	0.4	1.0	1.4	1.4	0.9	0.4	0.2	0.1	0.2	6.2
<b>1993</b>	0.0	0.0	0.1	0.4	1.0	1.4	1.4	0.9	0.4	0.2	0.1	0.2	6.2
<b>1994</b>	0.0	0.0	0.1	0.4	1.0	1.4	1.4	0.9	0.4	0.2	0.1	0.2	6.2
<b>1995</b>	0.0	0.0	0.1	0.4	1.0	1.4	1.4	0.9	0.4	0.2	0.1	0.2	6.2
<b>1996</b>	0.0	0.0	0.1	0.4	1.0	1.4	1.4	0.9	0.4	0.2	0.1	0.2	6.2
<b>1997</b>	0.0	0.0	0.1	0.4	1.0	1.4	1.4	0.9	0.4	0.2	0.1	0.2	6.2
<b>1998</b>	0.0	0.0	0.1	0.4	1.0	1.4	1.4	0.9	0.4	0.2	0.1	0.2	6.2
<b>1999</b>	0.0	0.0	0.1	0.4	1.0	1.4	1.4	0.9	0.4	0.2	0.1	0.2	6.2
<b>2000</b>	0.0	0.0	0.1	0.4	1.0	1.4	1.4	0.9	0.4	0.2	0.1	0.2	6.2
<b>2001</b>	0.0	0.0	0.1	0.4	1.0	1.4	1.4	0.9	0.4	0.2	0.1	0.2	6.2
<b>2002</b>	0.0	0.0	0.1	0.4	1.0	1.4	1.4	0.9	0.4	0.2	0.1	0.2	6.2
<b>2003</b>	0.0	0.0	0.1	0.4	1.0	1.4	1.4	0.9	0.4	0.2	0.1	0.2	6.2
<b>2004</b>	0.0	0.0	0.1	0.4	1.0	1.4	1.4	0.9	0.4	0.2	0.1	0.2	6.2
<b>2005</b>	0.0	0.0	0.1	0.4	1.0	1.4	1.4	0.9	0.4	0.2	0.1	0.2	6.2
<b>2006</b>	0.0	0.0	0.1	0.4	1.0	1.4	1.4	0.9	0.4	0.2	0.1	0.2	6.2
<b>2007</b>	0.0	0.0	0.1	0.4	1.0	1.4	1.4	0.9	0.4	0.2	0.1	0.2	6.2
<b>2008</b>	0.0	0.0	0.1	0.4	1.0	1.4	1.4	0.9	0.4	0.2	0.1	0.2	6.2
<b>2009</b>	0.0	0.0	0.1	0.4	1.0	1.4	1.4	0.9	0.4	0.2	0.1	0.2	6.2
<b>2010</b>	0.0	0.0	0.1	0.4	1.0	1.4	1.4	0.9	0.4	0.2	0.1	0.2	6.2
<b>Ave</b>	0.0	0.0	0.1	0.4	1.0	1.4	1.3	0.9	0.4	0.2	0.1	0.2	6.1
<b>Max</b>	0.0	0.0	0.1	0.4	1.0	1.4	1.4	0.9	0.4	0.2	0.1	0.2	6.2
<b>Min</b>	0.0	0.0	0.1	0.4	1.0	1.4	0.7	0.4	0.2	0.2	0.1	0.2	4.8

\*Note: Riparian diversions are the same for both the 2010 and 2040 baseline cases.

## **Appendix J: Unallocated Flow below Camanche as Modeled in MOCASIM**

Appendix J shows unallocated water below Camanche for the 2010 and 2040 baselines. Results indicate that there is generally more unallocated water in the months from January to May, and that there is more unallocated water in the 2010 baseline than in the 2040 baseline.

**Table J-1: 2010 Unallocated Water below Camanche (TAF)**

	<b>Jan</b>	<b>Feb</b>	<b>Mar</b>	<b>Apr</b>	<b>May</b>	<b>Jun</b>	<b>Jul</b>	<b>Aug</b>	<b>Sep</b>	<b>Oct</b>	<b>Nov</b>	<b>Dec</b>	<b>Total</b>
<b>1953</b>	24.7	0.0	0.0	0.0	23.3	22.5	23.3	23.3	22.5	0.0	0.0	0.0	139.5
<b>1954</b>	0.0	0.0	0.0	0.0	0.5	0.5	0.5	0.5	0.5	0.0	0.0	0.0	2.4
<b>1955</b>	0.0	0.0	0.0	0.0	0.0	0.0	0.0	0.0	0.0	0.0	0.0	121.0	121.0
<b>1956</b>	167.0	53.6	7.1	1.6	113.5	66.4	42.9	42.9	41.5	0.0	0.0	0.0	536.6
<b>1957</b>	0.0	0.0	0.0	0.0	11.2	10.8	11.2	11.2	10.8	0.0	0.0	0.0	55.3
<b>1958</b>	0.0	47.9	48.0	95.2	133.5	71.4	48.3	48.3	46.7	0.0	0.0	0.0	539.1
<b>1959</b>	0.0	0.0	0.0	0.0	0.0	0.0	0.0	0.0	0.0	0.0	0.0	0.0	0.0
<b>1960</b>	0.0	0.0	0.0	0.0	0.0	0.0	0.0	0.0	0.0	0.0	0.0	0.0	0.0
<b>1961</b>	0.0	0.0	0.0	0.0	0.0	0.0	0.0	0.0	0.0	0.0	0.0	0.0	0.0
<b>1962</b>	0.0	0.0	0.0	0.0	0.0	0.0	0.0	0.0	0.0	0.0	0.0	0.0	0.0
<b>1963</b>	0.0	62.3	0.0	0.0	77.3	50.4	37.9	37.9	36.7	0.0	23.0	0.0	325.5
<b>1964</b>	0.0	0.0	0.0	0.0	0.0	0.0	0.0	0.0	0.0	0.0	0.0	229.4	229.4
<b>1965</b>	128.3	35.1	0.0	12.2	50.7	49.1	50.7	50.7	49.1	0.0	19.2	2.8	447.8
<b>1966</b>	2.7	0.0	0.0	0.0	0.0	0.0	0.0	0.0	0.0	0.0	0.0	0.0	2.7
<b>1967</b>	25.7	16.3	48.8	55.0	165.1	60.0	62.0	62.0	60.0	0.0	0.0	0.0	554.8
<b>1968</b>	0.0	0.0	0.0	0.0	0.0	0.0	0.0	0.0	0.0	0.0	0.0	0.0	0.0
<b>1969</b>	149.1	78.2	39.8	123.6	176.8	67.8	51.9	51.9	50.3	0.0	0.0	9.9	799.4
<b>1970</b>	195.8	42.7	16.4	0.0	15.4	14.9	15.4	15.4	14.9	0.0	21.7	32.7	385.3
<b>1971</b>	26.9	17.5	17.8	0.0	26.4	25.6	26.4	26.4	25.6	0.0	4.9	7.3	204.8
<b>1972</b>	0.0	0.0	0.0	0.0	0.0	0.0	0.0	0.0	0.0	0.0	0.0	0.0	0.0
<b>1973</b>	45.6	57.0	27.5	0.0	28.9	27.9	28.9	28.9	27.9	0.0	64.4	39.2	376.3
<b>1974</b>	68.3	0.0	38.6	25.7	50.5	42.9	44.3	44.3	42.9	0.0	0.0	0.0	357.5
<b>1975</b>	0.0	0.0	0.0	0.0	50.7	49.0	50.7	50.7	49.0	0.0	4.6	0.0	254.8
<b>1976</b>	0.0	0.0	0.0	0.0	0.0	0.0	0.0	0.0	0.0	0.0	0.0	0.0	0.0
<b>1977</b>	0.0	0.0	0.0	0.0	0.0	0.0	0.0	0.0	0.0	0.0	0.0	0.0	0.0
<b>1978</b>	0.0	0.0	0.0	0.0	20.3	19.6	20.3	20.3	19.6	0.0	0.0	0.0	100.0
<b>1979</b>	0.0	5.7	22.8	0.1	25.6	24.8	25.6	25.6	24.8	0.0	0.0	0.0	155.1
<b>1980</b>	178.1	124.3	17.6	0.0	55.4	47.5	49.1	49.1	47.5	0.0	0.0	0.0	568.6
<b>1981</b>	0.0	0.0	0.0	0.0	0.0	0.0	0.0	0.0	0.0	0.0	0.0	87.2	87.2
<b>1982</b>	79.1	155.0	99.4	198.6	153.0	60.6	62.7	62.7	60.6	0.0	66.4	90.7	1,088.9
<b>1983</b>	70.6	113.7	198.8	93.3	237.8	169.8	100.7	100.7	97.4	0.0	122.3	151.3	1,456.5
<b>1984</b>	77.3	37.4	8.2	0.0	30.3	29.3	30.3	30.3	29.3	0.0	16.6	0.8	289.9
<b>1985</b>	0.0	0.0	0.0	0.0	0.0	0.0	0.0	0.0	0.0	0.0	0.0	0.0	0.0
<b>1986</b>	0.0	285.4	157.4	8.0	80.5	34.4	35.5	35.5	34.4	0.0	0.0	0.0	670.9

**Table J-1: 2010 Unallocated Water below Camanche (TAF)**

	<b>Jan</b>	<b>Feb</b>	<b>Mar</b>	<b>Apr</b>	<b>May</b>	<b>Jun</b>	<b>Jul</b>	<b>Aug</b>	<b>Sep</b>	<b>Oct</b>	<b>Nov</b>	<b>Dec</b>	<b>Total</b>
<b>1987</b>	0.0	0.0	0.0	0.0	0.0	0.0	0.0	0.0	0.0	0.0	0.0	0.0	0.0
<b>1988</b>	0.0	0.0	0.0	0.0	0.0	0.0	0.0	0.0	0.0	0.0	0.0	0.0	0.0
<b>1989</b>	0.0	0.0	0.0	0.0	0.0	0.0	0.0	0.0	0.0	0.0	0.0	0.0	0.0
<b>1990</b>	0.0	0.0	0.0	0.0	0.0	0.0	0.0	0.0	0.0	0.0	0.0	0.0	0.0
<b>1991</b>	0.0	0.0	0.0	0.0	0.0	0.0	0.0	0.0	0.0	0.0	0.0	0.0	0.0
<b>1992</b>	0.0	0.0	0.0	0.0	0.0	0.0	0.0	0.0	0.0	0.0	0.0	0.0	0.0
<b>1993</b>	0.0	0.0	0.0	0.0	35.8	34.7	35.8	35.8	34.7	0.0	0.0	0.0	176.8
<b>1994</b>	0.0	0.0	0.0	0.0	0.0	0.0	0.0	0.0	0.0	0.0	0.0	0.0	0.0
<b>1995</b>	0.0	33.2	167.0	138.0	242.1	89.5	78.3	78.3	75.8	0.0	0.0	0.0	902.3
<b>1996</b>	0.0	111.1	52.9	9.2	92.0	27.8	28.7	28.7	27.8	0.0	18.1	129.3	525.7
<b>1997</b>	359.2	74.9	12.8	0.0	12.7	12.3	12.7	12.7	12.3	0.0	10.2	0.0	520.1
<b>1998</b>	23.5	106.1	67.3	88.1	139.6	74.8	67.7	67.7	65.6	0.0	0.8	0.0	701.3
<b>1999</b>	20.9	90.4	29.0	0.0	41.3	46.2	39.2	39.2	38.0	0.0	0.0	0.0	344.3
<b>2000</b>	0.0	48.4	26.9	0.0	18.4	17.8	18.4	18.4	17.8	0.0	0.0	0.0	166.2
<b>2001</b>	0.0	0.0	0.0	0.0	0.0	0.0	0.0	0.0	0.0	0.0	0.0	0.0	0.0
<b>2002</b>	0.0	0.0	0.0	0.0	0.0	0.0	0.0	0.0	0.0	0.0	0.0	0.0	0.0
<b>2003</b>	0.0	0.1	0.0	0.0	16.7	16.2	16.7	16.7	16.2	0.0	0.0	0.0	82.6
<b>2004</b>	0.0	3.2	13.0	0.0	0.0	0.0	0.0	0.0	0.0	0.0	0.0	0.0	16.1
<b>2005</b>	0.0	31.9	67.6	29.6	95.3	54.3	40.0	40.0	38.7	0.0	0.0	91.6	489.0
<b>2006</b>	90.0	49.8	65.7	230.8	146.7	65.9	32.7	32.7	31.6	0.0	2.7	3.4	751.9
<b>2007</b>	0.0	0.0	0.0	0.0	0.0	0.0	0.0	0.0	0.0	0.0	0.0	0.0	0.0
<b>2008</b>	0.0	0.0	0.0	0.0	0.0	0.0	0.0	0.0	0.0	0.0	0.0	0.0	0.0
<b>2009</b>	0.0	0.0	0.0	0.0	5.0	4.8	5.0	5.0	4.8	0.0	0.0	0.0	24.7
<b>2010</b>	0.0	0.0	0.0	0.0	31.6	30.6	31.6	31.6	30.6	0.0	25.1	74.4	255.4
<b>Ave</b>	29.9	29.0	21.6	19.1	41.4	24.5	21.1	21.1	20.4	0.0	6.9	18.5	253.5
<b>Max</b>	359.2	285.4	198.8	230.8	242.1	169.8	100.7	100.7	97.4	0.0	122.3	229.4	1,456.5
<b>Min</b>	0.0	0.0	0.0	0.0	0.0	0.0	0.0	0.0	0.0	0.0	0.0	0.0	0.0

**Table J-2: 2040 Unallocated Water below Camanche (TAF)**

	<b>Jan</b>	<b>Feb</b>	<b>Mar</b>	<b>Apr</b>	<b>May</b>	<b>Jun</b>	<b>Jul</b>	<b>Aug</b>	<b>Sep</b>	<b>Oct</b>	<b>Nov</b>	<b>Dec</b>	<b>Total</b>
<b>1953</b>	23.3	0.0	0.0	0.0	16.5	16.0	16.5	16.5	16.0	0.0	0.0	0.0	105.0
<b>1954</b>	0.0	0.0	0.0	0.0	0.0	0.0	0.0	0.0	0.0	0.0	0.0	0.0	0.0
<b>1955</b>	0.0	0.0	0.0	0.0	0.0	0.0	0.0	0.0	0.0	0.0	0.0	108.1	108.1
<b>1956</b>	165.6	52.3	5.6	0.2	108.8	60.5	37.1	37.1	35.9	0.0	0.0	0.0	503.0
<b>1957</b>	0.0	0.0	0.0	0.0	4.0	3.9	4.0	4.0	3.9	0.0	0.0	0.0	19.7
<b>1958</b>	0.0	42.2	46.5	93.8	128.9	65.5	42.5	42.5	41.1	0.0	0.0	0.0	502.9
<b>1959</b>	0.0	0.0	0.0	0.0	0.0	0.0	0.0	0.0	0.0	0.0	0.0	0.0	0.0
<b>1960</b>	0.0	0.0	0.0	0.0	0.0	0.0	0.0	0.0	0.0	0.0	0.0	0.0	0.0
<b>1961</b>	0.0	0.0	0.0	0.0	0.0	0.0	0.0	0.0	0.0	0.0	0.0	0.0	0.0
<b>1962</b>	0.0	0.0	0.0	0.0	0.0	0.0	0.0	0.0	0.0	0.0	0.0	0.0	0.0
<b>1963</b>	0.0	105.9	0.0	0.0	64.0	43.9	31.6	31.6	30.5	0.0	21.5	0.0	329.0
<b>1964</b>	0.0	0.0	0.0	0.0	0.0	0.0	0.0	0.0	0.0	0.0	0.0	193.3	193.3
<b>1965</b>	126.9	33.8	0.0	9.1	45.4	43.6	45.0	45.0	43.6	0.0	17.7	1.3	411.3
<b>1966</b>	1.3	0.0	0.0	0.0	0.0	0.0	0.0	0.0	0.0	0.0	0.0	0.0	1.3
<b>1967</b>	4.4	15.1	47.3	53.7	160.6	54.5	56.3	56.3	54.5	0.0	0.0	0.0	502.6
<b>1968</b>	0.0	0.0	0.0	0.0	0.0	0.0	0.0	0.0	0.0	0.0	0.0	0.0	0.0
<b>1969</b>	142.3	77.0	38.5	122.2	172.2	61.9	46.2	46.2	44.7	0.0	0.0	6.9	758.2
<b>1970</b>	194.4	41.4	14.9	0.0	9.4	9.1	9.4	9.4	9.1	0.0	20.2	31.3	348.8
<b>1971</b>	25.5	16.2	16.3	0.0	20.3	19.6	20.3	20.3	19.6	0.0	3.4	5.9	167.2
<b>1972</b>	0.0	0.0	0.0	0.0	0.0	0.0	0.0	0.0	0.0	0.0	0.0	0.0	0.0
<b>1973</b>	22.8	55.7	26.0	0.0	23.2	22.5	23.2	23.2	22.5	0.0	62.9	37.7	319.9
<b>1974</b>	66.9	0.0	35.8	24.1	45.8	37.2	38.4	38.4	37.2	0.0	0.0	0.0	323.8
<b>1975</b>	0.0	0.0	0.0	0.0	43.1	41.7	43.1	43.1	41.7	0.0	3.1	0.0	215.7
<b>1976</b>	0.0	0.0	0.0	0.0	0.0	0.0	0.0	0.0	0.0	0.0	0.0	0.0	0.0
<b>1977</b>	0.0	0.0	0.0	0.0	0.0	0.0	0.0	0.0	0.0	0.0	0.0	0.0	0.0
<b>1978</b>	0.0	0.0	0.0	0.0	5.9	5.7	5.9	5.9	5.7	0.0	0.0	0.0	29.2
<b>1979</b>	0.0	0.0	21.3	0.0	19.5	18.8	19.5	19.5	18.8	0.0	0.0	0.0	117.4
<b>1980</b>	173.8	123.0	16.1	0.0	49.3	41.8	43.2	43.2	41.8	0.0	0.0	0.0	532.2
<b>1981</b>	0.0	0.0	0.0	0.0	0.0	0.0	0.0	0.0	0.0	0.0	0.0	72.3	72.3
<b>1982</b>	77.7	153.7	97.9	197.0	148.1	54.8	56.6	56.6	54.8	0.0	64.9	89.3	1,051.2
<b>1983</b>	69.2	112.5	197.3	91.7	232.8	163.7	94.7	94.7	91.6	0.0	120.8	149.9	1,418.9
<b>1984</b>	75.9	36.1	6.8	0.0	24.1	23.3	24.1	24.1	23.3	0.0	15.1	0.0	252.9
<b>1985</b>	0.0	0.0	0.0	0.0	0.0	0.0	0.0	0.0	0.0	0.0	0.0	0.0	0.0

**Table J-2: 2040 Unallocated Water below Camanche (TAF)**

	<b>Jan</b>	<b>Feb</b>	<b>Mar</b>	<b>Apr</b>	<b>May</b>	<b>Jun</b>	<b>Jul</b>	<b>Aug</b>	<b>Sep</b>	<b>Oct</b>	<b>Nov</b>	<b>Dec</b>	<b>Total</b>
<b>1986</b>	0.0	260.7	155.9	6.8	76.0	28.9	29.9	29.9	28.9	0.0	0.0	0.0	616.9
<b>1987</b>	0.0	0.0	0.0	0.0	0.0	0.0	0.0	0.0	0.0	0.0	0.0	0.0	0.0
<b>1988</b>	0.0	0.0	0.0	0.0	0.0	0.0	0.0	0.0	0.0	0.0	0.0	0.0	0.0
<b>1989</b>	0.0	0.0	0.0	0.0	0.0	0.0	0.0	0.0	0.0	0.0	0.0	0.0	0.0
<b>1990</b>	0.0	0.0	0.0	0.0	0.0	0.0	0.0	0.0	0.0	0.0	0.0	0.0	0.0
<b>1991</b>	0.0	0.0	0.0	0.0	0.0	0.0	0.0	0.0	0.0	0.0	0.0	0.0	0.0
<b>1992</b>	0.0	0.0	0.0	0.0	0.0	0.0	0.0	0.0	0.0	0.0	0.0	0.0	0.0
<b>1993</b>	0.0	0.0	0.0	0.0	24.8	24.0	24.8	24.8	24.0	0.0	0.0	0.0	122.3
<b>1994</b>	0.0	0.0	0.0	0.0	0.0	0.0	0.0	0.0	0.0	0.0	0.0	0.0	0.0
<b>1995</b>	0.0	18.7	165.7	136.5	237.3	83.5	72.5	72.5	70.1	0.0	0.0	0.0	856.7
<b>1996</b>	0.0	105.4	51.4	7.8	87.4	22.2	22.9	22.9	22.2	0.0	16.6	127.9	486.6
<b>1997</b>	357.8	73.7	11.3	0.0	6.8	6.6	6.8	6.8	6.6	0.0	8.7	0.0	485.2
<b>1998</b>	20.6	104.8	65.9	86.7	134.9	68.9	61.9	61.9	59.9	0.0	0.0	0.0	665.7
<b>1999</b>	17.3	89.2	27.5	0.0	35.4	40.1	33.4	33.4	32.4	0.0	0.0	0.0	308.8
<b>2000</b>	0.0	42.7	25.4	0.0	12.2	11.9	12.2	12.2	11.9	0.0	0.0	0.0	128.5
<b>2001</b>	0.0	0.0	0.0	0.0	0.0	0.0	0.0	0.0	0.0	0.0	0.0	0.0	0.0
<b>2002</b>	0.0	0.0	0.0	0.0	0.0	0.0	0.0	0.0	0.0	0.0	0.0	0.0	0.0
<b>2003</b>	0.0	0.0	0.0	0.0	2.9	2.8	2.9	2.9	2.8	0.0	0.0	0.0	14.2
<b>2004</b>	0.0	0.0	9.0	0.0	0.0	0.0	0.0	0.0	0.0	0.0	0.0	0.0	9.0
<b>2005</b>	0.0	11.9	66.1	27.9	90.8	48.6	34.4	34.4	33.3	0.0	0.0	88.7	436.1
<b>2006</b>	88.6	48.5	64.3	229.4	142.0	60.0	26.9	26.9	26.0	0.0	1.2	2.0	715.7
<b>2007</b>	0.0	0.0	0.0	0.0	0.0	0.0	0.0	0.0	0.0	0.0	0.0	0.0	0.0
<b>2008</b>	0.0	0.0	0.0	0.0	0.0	0.0	0.0	0.0	0.0	0.0	0.0	0.0	0.0
<b>2009</b>	0.0	0.0	0.0	0.0	0.0	0.0	0.0	0.0	0.0	0.0	0.0	0.0	0.0
<b>2010</b>	0.0	0.0	0.0	0.0	22.7	22.0	22.7	22.7	22.0	0.0	23.6	72.9	208.7
<b>Ave</b>	28.5	27.9	20.9	18.7	37.9	20.8	17.4	17.4	16.8	0.0	6.5	17.0	230.0
<b>Max</b>	357.8	260.7	197.3	229.4	237.3	163.7	94.7	94.7	91.6	0.0	120.8	193.3	1,418.9
<b>Min</b>	0.0	0.0	0.0	0.0	0.0	0.0	0.0	0.0	0.0	0.0	0.0	0.0	0.0



## **Appendix K: Relevant Tables and Figures in Cubic Feet per Second (cfs)**

Appendix K presents data for all relevant figures and tables from Appendices D through J in cubic feet per second (cfs) rather than in acre-feet. The values stated provide the average flow in cfs over the time period specified (year, month, etc.). One acre-foot per year is equivalent to 0.00138 cfs.

**Table K-1: Presented as Table 19: Diversion Assumptions for  
Current (2010) and Future (2040) Baselines**  
Values shown provide flow in cubic feet per second (cfs) averaged over the year

<b>Agency</b>	<b>2010 Baseline Diversions (cfs)</b>	<b>2040 Baseline Diversions (cfs)</b>
<b>Amador Water Agency (AWA)<sup>1</sup></b>	11	19
<b>Calaveras County Water District (CCWD)<sup>2</sup></b>	3	3
<b>Calaveras Public Utility District (CPUD)<sup>3</sup></b>	2	4
<b>East Bay Municipal Utility District (EBMUD)<sup>4</sup></b>	334	355
<b>Jackson Valley Irrigation District (JVID)<sup>5</sup></b>	5	4
<b>North San Joaquin Water Conservation District (NSJWCD)<sup>6</sup></b>	4	28
<b>Woodbridge Irrigation District (WID)<sup>7</sup></b>	99	99
<b>TOTAL</b>	<b>459</b>	<b>512</b>

<sup>1</sup> 2010 diversions reflect 97% of historic and projected reported total water use in the AWA 2010 Urban Water Management Plan (UWMP), as 97% of supply is surface water from the Mokelumne River. Projected 2040 diversions are extrapolated from the AWA 2010 UWMP, which reports projected demands through 2030. It is understood that demand may differ in the future from what is presented here depending on actual growth and water use in the AWA service area.

<sup>2</sup> Historic and projected diversions reflect actual and projected data presented in the CCWD 2010 UWMP. It should be noted that projected 2040 use could change significantly in future years, and projections are expected to increase in the 2015 UWMP. However, these are the best available projections currently.

<sup>3</sup> CPUD diversions are confirmed by CPUD and are based on the 2008 Master Plan and 2008-2013 usage summary.

<sup>4</sup> EBMUD 2010 and 2040 diversions based on information provided by the EBMUD Water Resources Division for Mokelumne Supplies.

<sup>5</sup> JVID shares a 5,000 AF right under CAWP with AWA and can currently take up to 3,850 AF. AWA anticipates increasing their portion of the right from 1,250 AF to 2,200 AF, which will decrease JVID's portion to 2,800 AF by 2040.

<sup>6</sup> NSJWCD 2010 diversion reflects actual diversions in 2010. Projected 2040 diversions based on capacity and projected demand.

<sup>7</sup> WID can currently take 60,000 AFY, plus additional spill (which is used for irrigation). In recent years, WID has reported diverting 72,000 AFY. The additional spill is obtainable under WID's combined pre 1914 water rights (1886) and the State Water Resources Control Board (SWRCB) licenses 5945 and 8214. WID's simultaneous diversion under License 5945 and the pre-1914 right may not exceed 300 cfs. WID's water right under License 8214 allows 114 cfs to be diverted from the Mokelumne. All combined, diversions cannot exceed 414.4 cfs.

**Table K-2: Presented as Table E-8: Unallocated, Regulated, and Natural Flow Comparison for January through July below Camanche (2010) (in TAF)\***  
Values shown provide flow in cubic feet per second (cfs) averaged over the monthly period indicated

	January			February			March			April			May			June			July		
	Unallocated	Regulated	Natural	Unallocated	Regulated	Natural	Unallocated	Regulated	Natural	Unallocated	Regulated	Natural	Unallocated	Regulated	Natural	Unallocated	Regulated	Natural	Unallocated	Regulated	Natural
1953	410.0	1,011.5	1,137.9	0.0	679.8	528.8	0.0	747.6	855.0	0.0	1,033.0	2,176.7	386.2	1,262.7	2,515.8	373.8	2,067.0	2,641.7	386.2	918.0	660.1
1954	0.0	635.1	431.9	0.0	629.2	618.5	0.0	940.6	1,470.8	0.0	1,219.2	2,626.1	8.0	1,471.7	2,720.6	7.8	705.3	707.1	8.0	539.8	223.3
1955	0.0	496.5	532.1	0.0	447.3	458.3	0.0	616.7	656.3	0.0	496.4	1,128.5	0.0	808.4	2,855.4	0.0	886.0	1,619.6	0.0	560.6	185.7
1956	2,772.2	2,971.2	3,441.7	889.8	1,640.0	1,289.2	118.0	1,586.5	1,301.7	26.7	1,619.9	1,959.0	1,883.8	3,191.1	4,581.2	1,102.4	3,270.4	3,408.9	712.3	856.1	701.8
1957	0.0	605.1	249.8	0.0	677.2	942.6	0.0	813.6	1,513.8	0.0	700.6	1,522.3	186.0	1,553.3	2,993.7	180.0	2,149.1	2,219.6	186.0	563.5	243.9
1958	0.0	797.9	431.4	794.3	1,329.4	1,446.7	796.7	1,563.2	1,725.3	1,579.5	2,368.9	3,275.1	2,216.6	3,341.8	5,860.1	1,184.9	3,574.8	3,691.5	801.2	1,029.0	875.1
1959	0.0	654.6	525.1	0.0	743.5	706.0	0.0	675.6	904.0	0.0	399.4	1,646.5	0.0	445.3	1,514.4	0.0	514.3	583.9	0.0	546.0	50.0
1960	0.0	340.8	139.1	0.0	567.8	829.3	0.0	516.3	1,266.5	0.0	518.0	1,757.0	0.0	961.6	2,042.8	0.0	897.8	698.1	0.0	522.5	61.7
1961	0.0	387.2	128.7	0.0	252.6	326.2	0.0	292.5	487.8	0.0	307.2	1,213.1	0.0	367.4	1,749.7	0.0	503.5	563.1	0.0	518.7	23.8
1962	0.0	344.3	146.7	0.0	908.5	1,216.8	0.0	843.4	832.6	0.0	1,450.3	2,905.2	0.0	1,151.1	2,727.1	0.0	2,183.8	2,329.1	0.0	654.5	281.7
1963	0.0	780.0	721.1	1,034.1	1,371.8	2,822.3	0.0	767.9	762.5	0.0	1,741.3	2,170.7	1,283.0	3,569.3	4,496.0	837.2	2,322.0	2,335.7	629.0	699.9	456.1
1964	0.0	781.4	413.7	0.0	616.6	367.9	0.0	564.6	526.3	0.0	529.6	1,418.3	0.0	541.7	2,413.6	0.0	562.3	1,165.7	0.0	607.8	147.0
1965	2,129.0	2,684.8	2,577.1	582.9	1,435.0	1,204.2	0.0	1,225.5	1,055.1	202.3	1,890.5	2,696.4	841.9	2,239.3	3,405.8	814.7	2,687.6	2,800.0	841.9	952.6	761.3
1966	44.4	682.4	390.7	0.0	388.7	380.5	0.0	701.8	1,153.7	0.0	858.7	2,264.0	0.0	771.9	2,105.1	0.0	453.9	750.9	0.0	554.2	72.8
1967	427.3	1,128.8	1,074.1	271.0	909.0	964.7	809.5	1,657.2	2,041.7	912.8	1,816.5	1,933.1	2,740.9	2,700.1	4,930.6	995.4	4,158.1	4,952.3	1,028.5	2,139.6	2,073.8
1968	0.0	651.3	334.6	0.0	763.9	1,204.0	0.0	759.7	1,037.3	0.0	627.5	1,452.7	0.0	499.5	1,924.6	0.0	630.4	596.7	0.0	516.7	65.2
1969	2,475.3	2,693.1	3,351.5	1,298.7	1,719.4	1,756.4	660.3	1,617.6	1,477.2	2,051.7	2,471.7	3,498.6	2,935.3	4,695.4	6,351.3	1,125.1	3,661.6	3,881.4	862.1	1,193.9	1,021.1
1970	3,249.9	2,693.0	4,029.4	709.0	1,404.2	1,340.0	272.4	1,660.8	1,416.9	0.0	1,124.9	1,260.9	255.5	1,921.2	3,108.1	247.3	1,996.2	1,952.5	255.5	759.1	306.0
1971	446.0	1,082.1	945.7	289.9	1,020.9	817.3	294.8	1,286.2	1,202.9	0.0	1,216.7	1,792.5	438.9	1,106.9	2,836.9	424.7	2,142.5	3,019.1	438.9	994.5	524.8
1972	0.0	609.6	339.1	0.0	494.8	543.9	0.0	954.4	1,661.3	0.0	815.0	1,333.7	0.0	659.3	2,667.3	0.0	1,187.3	1,126.4	0.0	636.7	115.9
1973	756.6	1,276.0	1,320.8	946.5	1,315.9	1,252.6	457.0	1,319.3	1,142.7	0.0	1,288.7	2,095.9	479.4	2,291.6	4,644.0	463.9	1,701.8	1,793.5	479.4	778.6	167.4
1974	1,133.4	1,515.4	1,881.3	0.0	1,055.9	622.2	640.1	1,958.4	2,032.5	426.9	1,902.2	2,345.0	838.4	2,330.2	4,156.0	712.0	2,337.7	2,471.8	735.7	1,033.0	592.5
1975	0.0	470.3	296.5	0.0	617.1	693.5	0.0	1,246.5	1,418.2	0.0	1,217.7	1,185.2	841.3	1,805.6	4,252.5	814.2	2,956.2	3,877.6	841.3	1,122.9	688.4
1976	0.0	468.3	165.5	0.0	224.2	229.6	0.0	271.5	467.4	0.0	280.2	735.9	0.0	308.0	1,192.7	0.0	281.8	130.6	0.0	284.7	23.0
1977	0.0	184.0	67.1	0.0	100.1	107.6	0.0	124.6	152.3	0.0	226.8	596.0	0.0	304.0	715.4	0.0	269.0	421.1	0.0	280.7	27.0
1978	0.0	1,199.5	1,471.3	0.0	1,089.3	1,017.9	0.0	1,610.8	2,147.4	0.0	1,891.8	2,529.4	336.4	1,882.9	3,950.0	325.6	3,174.6	3,580.3	336.4	1,122.8	839.6
1979	0.0	815.4	789.7	93.8	816.4	784.5	379.2	1,355.2	1,565.1	1.6	1,435.2	2,005.1	425.3	1,968.1	4,346.5	411.6	1,530.6	1,565.3	425.3	655.3	202.5
1980	2,957.2	2,779.6	4,122.8	2,062.7	2,553.1	2,783.7	292.0	1,896.2	1,646.6	0.0	1,448.7	2,205.1	919.8	2,213.8	3,372.7	788.4	2,836.9	2,911.7	814.7	1,308.9	1,134.3
1981	0.0	696.9	308.1	0.0	576.9	447.8	0.0	576.8	780.6	0.0	690.6	1,842.2	0.0	532.0	2,097.9	0.0	536.5	532.8	0.0	572.4	6.5
1982	1,312.9	1,817.5	1,697.3	2,572.2	2,759.9	3,426.1	1,649.8	2,599.6	2,556.3	3,296.5	4,070.4	5,036.3	2,540.3	4,769.9	5,214.4	1,006.8	3,021.0	3,096.3	1,040.3	1,309.8	921.7
1983	1,172.5	1,981.0	1,694.4	1,888.2	2,505.2	2,395.6	3,300.6	4,038.8	4,447.6	1,549.2	2,329.6	2,372.5	3,946.7	3,497.9	5,316.3	2,819.1	6,182.6	6,306.5	1,671.0	3,471.9	3,425.9
1984	1,283.5	1,899.2	1,451.9	621.3	1,466.0	934.4	136.9	1,606.3	1,411.0	0.0	1,330.4	1,437.4	502.7	2,413.6	3,615.2	486.5	1,823.2	1,646.0	502.7	977.3	294.0
1985	0.0	409.0	262.0	0.0	587.1	464.9	0.0	849.7	691.3	0.0	1,032.4	2,152.2	0.0	545.7	2,357.1	0.0	508.5	567.0	0.0	519.3	71.5
1986	0.0	877.6	1,144.9	4,736.8	4,421.5	5,649.6	2,612.1	3,193.5	4,312.4	132.4	2,076.0	2,361.3	1,335.8	3,222.3	3,554.9	570.3	2,211.6	2,367.3	589.3	761.1	406.8
1987	0.0	426.1	130.7	0.0	297.9	352.4	0.0	420.0	691.8	0.0	372.4	1,413.3	0.0	296.3	1,324.1	0.0	367.7	193.0	0.0	550.6	36.4
1988	0.0	367.6	296.5	0.0	247.2	333.3	0.0	291.3	689.2	0.0	320.8	1,123.3	0.0	390.2	1,133.8	0.0	457.2	375.6	0.0	480.1	61.9
1989	0.0	231.5	183.1	0.0	250.2	413.0	0.0	1,011.8	2,405.4	0.0	1,353.0	2,519.5	0.0	1,770.6	2,163.7	0.0	1,174.3	1,050.5	0.0	588.3	105.8

**Table K-2: Presented as Table E-8: Unallocated, Regulated, and Natural Flow Comparison for January through July below Camanche (2010) (in TAF)\***  
**Values shown provide flow in cubic feet per second (cfs) averaged over the monthly period indicated**

	January			February			March			April			May			June			July		
	Unallocated	Regulated	Natural	Unallocated	Regulated	Natural	Unallocated	Regulated	Natural	Unallocated	Regulated	Natural	Unallocated	Regulated	Natural	Unallocated	Regulated	Natural	Unallocated	Regulated	Natural
1990	0.0	552.9	287.7	0.0	378.3	307.1	0.0	552.6	982.3	0.0	405.3	1,620.0	0.0	554.7	1,197.6	0.0	575.7	563.5	0.0	553.6	60.2
1991	0.0	80.9	59.2	0.0	136.0	67.2	0.0	380.1	855.6	0.0	438.7	1,108.7	0.0	512.2	2,218.3	0.0	733.1	1,323.6	0.0	565.9	146.0
1992	0.0	387.7	167.1	0.0	486.1	690.8	0.0	661.9	893.1	0.0	408.3	1,785.3	0.0	360.9	944.7	0.0	309.9	140.6	0.0	513.3	146.1
1993	0.0	1,261.6	1,745.8	0.0	1,225.5	1,150.2	0.0	2,003.0	2,577.7	0.0	1,726.0	2,481.0	594.6	2,940.2	4,529.3	575.4	2,951.0	3,157.6	594.6	891.6	717.3
1994	0.0	345.5	165.1	0.0	269.7	286.9	0.0	312.6	722.0	0.0	293.9	1,294.2	0.0	370.2	1,563.9	0.0	488.8	462.4	0.0	399.3	36.0
1995	0.0	1,825.1	2,404.6	551.0	1,218.5	1,214.2	2,772.7	3,386.5	4,206.0	2,291.2	2,728.3	3,135.1	4,018.2	4,159.5	5,516.9	1,485.2	5,026.4	5,265.0	1,300.4	3,035.6	3,234.1
1996	0.0	740.7	908.6	1,844.7	1,896.2	2,753.8	877.5	2,157.7	2,187.3	152.7	1,977.1	2,537.8	1,527.8	3,785.6	4,313.2	461.7	1,892.7	1,946.4	477.1	759.4	415.5
1997	5,962.7	5,790.2	7,348.6	1,243.7	1,869.2	1,445.0	212.2	1,574.0	1,411.8	0.0	1,580.3	2,063.8	211.6	2,460.3	2,903.7	204.8	1,360.4	1,158.8	211.6	660.6	185.9
1998	390.1	1,038.6	1,370.6	1,760.9	2,053.2	2,342.7	1,118.0	2,112.3	2,650.9	1,462.2	2,057.8	2,642.5	2,317.9	2,683.3	3,704.9	1,242.1	4,694.5	5,797.6	1,124.4	2,247.8	2,286.5
1999	346.5	1,148.3	1,016.4	1,501.1	1,990.0	2,172.9	481.7	1,505.9	1,383.3	0.0	1,448.2	1,867.7	686.1	2,055.4	4,062.9	767.2	2,575.1	2,755.4	651.4	994.4	470.5
2000	0.0	847.0	1,032.6	802.9	1,374.5	1,882.1	446.4	1,562.4	1,589.0	0.0	1,132.7	2,233.9	305.8	2,133.0	3,439.5	295.9	1,384.1	1,148.2	305.8	855.6	164.9
2001	0.0	327.9	212.4	0.0	301.8	347.2	0.0	633.5	1,061.2	0.0	896.7	1,488.7	0.0	742.0	2,329.1	0.0	539.3	203.4	0.0	572.3	67.2
2002	0.0	897.6	722.5	0.0	605.7	611.3	0.0	1,158.2	1,099.0	0.0	1,097.6	2,190.9	0.0	889.3	2,674.6	0.0	1,019.6	1,039.7	0.0	531.5	170.3
2003	0.0	948.9	633.9	1.5	825.2	550.9	0.0	799.7	946.6	0.0	992.2	1,603.1	277.4	1,758.0	3,592.1	268.4	2,055.2	2,196.7	277.4	599.8	268.5
2004	0.0	859.7	378.4	53.0	832.0	812.9	215.0	1,306.8	1,843.6	0.0	785.9	2,018.2	0.0	473.1	1,926.8	0.0	793.7	500.3	0.0	542.2	74.6
2005	0.0	1,392.7	1,200.9	529.7	1,300.5	1,081.3	1,121.7	2,055.3	1,968.6	490.6	2,027.2	2,084.3	1,581.5	3,006.3	5,317.4	900.9	2,817.1	3,298.9	664.2	1,219.9	827.0
2006	1,494.3	1,824.8	2,353.4	826.1	1,325.7	1,591.1	1,091.3	2,650.9	2,182.4	3,830.7	4,846.6	5,190.4	2,435.1	4,874.6	5,916.9	1,093.4	3,170.1	3,182.1	542.6	1,172.0	551.3
2007	0.0	544.0	301.9	0.0	593.4	891.9	0.0	774.9	1,237.1	0.0	481.5	1,638.7	0.0	590.3	1,590.0	0.0	472.1	286.5	0.0	534.9	113.0
2008	0.0	493.9	368.0	0.0	512.3	463.3	0.0	771.2	840.5	0.0	479.5	1,373.9	0.0	672.0	2,374.6	0.0	589.7	849.2	0.0	403.6	93.2
2009	0.0	696.4	527.5	0.0	638.5	751.7	0.0	1,325.1	1,710.6	0.0	1,159.1	1,883.5	83.1	2,653.6	4,035.4	80.4	958.5	898.2	83.1	661.6	161.9
2010	0.0	759.0	443.4	0.0	707.6	514.3	0.0	984.9	974.8	0.0	1,355.0	1,723.8	524.3	1,941.7	2,830.2	507.4	2,207.3	3,910.8	524.3	808.3	505.2

\* Unallocated water is simulated below Camanche and regulated and unimpaired flow is simulated at Mokelumne Hill.

**Table K-3: Presented as Table E-9: Unallocated, Regulated, and Natural Flow Comparison for August through December below Camanche (2010) (in TAF)\***  
**Values shown provide flow in cubic feet per second (cfs) averaged over the monthly period indicated**

	August			September			October			November			December			Total		
	Unallocated	Regulated	Natural	Unallocated	Regulated	Natural	Unallocated	Regulated	Natural	Unallocated	Regulated	Natural	Unallocated	Regulated	Natural	Unallocated	Regulated	Natural
1953	386.2	622.5	66.6	373.8	630.7	37.2	0.0	699.3	94.4	0.0	652.7	188.7	0.0	630.9	244.5	2,316.3	10,955.6	11,147.5
1954	8.0	578.8	0.0	7.8	610.5	38.6	0.0	633.0	67.5	0.0	681.0	131.0	0.0	575.2	474.7	39.7	9,219.4	9,510.1
1955	0.0	571.6	45.9	0.0	541.3	15.0	0.0	559.3	39.5	0.0	560.9	96.2	2,008.1	2,710.2	4,312.9	2,008.1	9,255.1	11,945.4
1956	712.3	614.4	108.7	689.4	570.5	72.8	0.0	665.3	151.0	0.0	714.6	177.9	0.0	751.0	219.5	8,907.0	18,451.1	17,413.3
1957	186.0	523.2	40.0	180.0	537.6	38.9	0.0	660.8	67.2	0.0	723.3	119.6	0.0	723.0	267.1	917.8	10,230.4	10,218.4
1958	801.2	745.6	144.6	775.3	595.4	61.5	0.0	664.2	65.1	0.0	636.5	92.0	0.0	561.8	82.2	8,949.7	17,208.5	17,750.5
1959	0.0	543.3	2.4	0.0	513.1	77.0	0.0	541.4	36.9	0.0	507.8	31.8	0.0	534.7	54.0	0.0	6,619.0	6,132.2
1960	0.0	528.1	0.0	0.0	510.6	17.3	0.0	516.6	8.2	0.0	500.2	110.2	0.0	529.4	179.2	0.0	6,909.6	7,109.5
1961	0.0	500.0	0.0	0.0	500.5	4.2	0.0	514.4	6.6	0.0	317.0	63.0	0.0	311.7	172.1	0.0	4,772.5	4,738.2
1962	0.0	618.7	39.3	0.0	568.8	0.4	0.0	669.4	331.9	0.0	627.5	113.2	0.0	629.0	307.4	0.0	10,649.3	11,231.7
1963	629.0	645.4	47.2	608.7	607.1	56.4	0.0	633.6	115.7	381.9	691.8	770.7	0.0	725.1	397.5	5,403.0	14,555.2	15,151.7
1964	0.0	585.8	34.0	0.0	575.2	40.7	0.0	609.6	73.2	0.0	711.4	259.0	3,807.8	3,365.5	5,237.0	3,807.8	10,051.5	12,096.4
1965	841.9	753.3	346.9	814.7	931.2	115.9	0.0	931.4	88.4	318.4	946.1	440.4	46.3	771.4	363.1	7,434.1	17,448.6	15,854.4
1966	0.0	557.6	17.3	0.0	601.7	30.9	0.0	554.2	24.5	0.0	668.2	292.8	0.0	1,191.3	1,199.4	44.4	7,984.7	8,682.5
1967	1,028.5	672.7	231.6	995.4	639.6	87.2	0.0	658.0	89.0	0.0	662.8	118.0	0.0	667.7	183.2	9,209.4	17,810.1	18,679.3
1968	0.0	525.3	42.1	0.0	537.7	16.8	0.0	543.8	75.6	0.0	665.3	572.9	0.0	739.7	396.6	0.0	7,460.7	7,719.0
1969	862.1	830.3	116.4	834.3	776.0	62.1	0.0	804.8	184.3	0.0	659.2	195.2	164.6	910.4	1,090.2	13,269.4	22,033.4	22,985.8
1970	255.5	589.5	64.1	247.3	567.9	5.8	0.0	608.1	47.6	359.8	871.3	516.4	543.5	1,237.0	893.6	6,395.5	15,433.1	14,941.3
1971	438.9	905.1	55.9	424.7	688.6	9.0	0.0	736.2	52.7	81.3	552.0	200.4	121.8	688.4	494.9	3,399.8	12,420.1	11,952.2
1972	0.0	567.0	15.4	0.0	561.9	15.5	0.0	622.2	72.3	0.0	659.0	187.8	0.0	764.6	641.0	0.0	8,531.8	8,719.6
1973	479.4	575.2	25.7	463.9	576.9	0.2	0.0	643.3	105.3	1,069.6	911.3	1,421.1	650.2	1,261.2	1,225.1	6,245.8	13,939.7	15,194.5
1974	735.7	937.0	96.6	712.0	740.6	14.9	0.0	594.7	51.8	0.0	509.2	87.1	0.0	547.0	188.0	5,934.2	15,461.3	14,539.6
1975	841.3	925.4	123.4	814.2	878.5	48.4	0.0	760.0	363.6	77.1	690.6	380.7	0.0	647.6	199.2	4,229.5	13,338.5	13,527.3
1976	0.0	295.5	71.2	0.0	285.5	35.8	0.0	204.8	32.9	0.0	203.1	41.3	0.0	150.8	31.8	0.0	3,258.2	3,157.6
1977	0.0	273.0	22.7	0.0	291.1	22.5	0.0	18.4	13.7	0.0	48.5	57.2	0.0	393.1	489.7	0.0	2,513.4	2,692.5
1978	336.4	880.0	62.2	325.6	675.7	225.5	0.0	611.7	35.9	0.0	570.5	86.8	0.0	524.9	145.6	1,660.4	15,234.6	16,091.7
1979	425.3	599.4	52.1	411.6	531.6	3.0	0.0	578.5	149.5	0.0	646.0	300.0	0.0	804.0	330.5	2,573.9	11,735.8	12,093.9
1980	814.7	611.1	123.4	788.4	574.5	48.8	0.0	586.1	41.0	0.0	552.2	49.2	0.0	629.5	134.2	9,438.0	17,990.6	18,573.6
1981	0.0	475.2	8.5	0.0	499.6	8.8	0.0	581.7	92.6	0.0	747.0	1,297.8	1,447.0	1,385.0	2,201.5	1,447.0	7,870.5	9,625.0
1982	1,040.3	919.7	131.9	1,006.8	714.7	226.9	0.0	788.0	1,124.8	1,102.7	1,385.4	1,025.2	1,506.3	2,025.4	1,811.9	18,074.9	26,181.2	26,269.2
1983	1,671.0	1,162.5	514.4	1,617.1	956.9	279.6	0.0	931.6	173.3	2,030.8	1,928.6	2,658.5	2,512.1	2,980.2	3,126.9	24,178.5	31,966.7	32,711.3
1984	502.7	832.6	59.0	486.5	587.4	21.7	0.0	647.9	78.0	275.6	768.2	516.6	13.5	716.5	275.1	4,811.8	15,068.5	11,740.3
1985	0.0	573.4	24.5	0.0	565.3	44.4	0.0	616.3	31.9	0.0	657.5	195.6	0.0	659.9	419.1	0.0	7,524.0	7,281.3
1986	589.3	641.7	111.7	570.3	617.8	32.5	0.0	629.9	26.5	0.0	627.4	27.3	0.0	552.4	58.0	11,136.4	19,832.9	20,053.2
1987	0.0	536.2	11.7	0.0	475.1	11.2	0.0	250.8	29.9	0.0	229.1	33.8	0.0	302.4	58.0	0.0	4,524.5	4,286.3
1988	0.0	402.5	13.1	0.0	350.3	10.9	0.0	236.9	3.4	0.0	220.6	157.8	0.0	227.1	156.3	0.0	3,991.8	4,355.1
1989	0.0	535.1	29.7	0.0	560.3	61.1	0.0	400.6	168.6	0.0	612.5	211.9	0.0	590.6	170.4	0.0	9,078.8	9,482.7

**Table K-3: Presented as Table E-9: Unallocated, Regulated, and Natural Flow Comparison for August through December below Camanche (2010) (in TAF)\***  
 Values shown provide flow in cubic feet per second (cfs) averaged over the monthly period indicated

	August			September			October			November			December			Total		
	Unallocated	Regulated	Natural	Unallocated	Regulated	Natural	Unallocated	Regulated	Natural	Unallocated	Regulated	Natural	Unallocated	Regulated	Natural	Unallocated	Regulated	Natural
1990	0.0	492.9	16.4	0.0	479.7	6.8	0.0	538.4	6.1	0.0	154.3	15.7	0.0	204.2	52.2	0.0	5,442.7	5,115.8
1991	0.0	495.5	32.9	0.0	494.8	0.0	0.0	553.4	94.0	0.0	566.2	143.2	0.0	521.4	144.8	0.0	5,478.0	6,193.5
1992	0.0	500.9	19.7	0.0	337.7	36.0	0.0	332.6	36.8	0.0	255.0	89.3	0.0	408.3	310.9	0.0	4,962.7	5,260.4
1993	594.6	900.2	162.9	575.4	587.7	66.6	0.0	673.9	72.1	0.0	532.9	43.6	0.0	537.9	67.5	2,934.6	16,231.6	16,771.6
1994	0.0	440.7	21.8	0.0	553.5	18.7	0.0	555.0	48.2	0.0	240.2	251.9	0.0	546.6	340.8	0.0	4,815.8	5,211.9
1995	1,300.4	847.0	504.7	1,258.5	786.0	124.9	0.0	842.4	78.0	0.0	564.7	73.2	0.0	607.5	519.6	14,977.7	25,027.7	26,276.4
1996	477.1	741.6	100.7	461.7	577.9	39.1	0.0	553.1	0.0	300.4	884.2	670.3	2,146.7	2,349.0	2,685.3	8,727.3	18,315.2	18,558.1
1997	211.6	689.3	75.8	204.8	614.0	54.8	0.0	660.6	37.0	170.0	695.5	147.7	0.0	467.0	191.9	8,633.0	18,421.5	17,024.9
1998	1,124.4	976.6	264.3	1,088.2	832.0	134.0	0.0	709.9	125.0	13.3	696.0	293.4	0.0	819.8	422.3	11,641.6	20,921.8	22,034.5
1999	651.4	691.1	126.8	630.3	628.1	58.0	0.0	588.8	26.6	0.0	660.6	164.2	0.0	574.3	138.0	5,715.7	14,860.1	14,242.6
2000	305.8	722.1	27.3	295.9	552.1	68.9	0.0	575.8	86.8	0.0	604.9	103.8	0.0	578.0	93.1	2,758.5	12,322.1	11,870.0
2001	0.0	532.2	38.2	0.0	466.8	60.0	0.0	427.1	0.0	0.0	336.6	232.0	0.0	617.1	542.0	0.0	6,393.4	6,581.5
2002	0.0	523.6	28.6	0.0	497.9	0.0	0.0	531.0	19.8	0.0	567.6	332.1	0.0	677.6	376.5	0.0	8,997.2	9,265.2
2003	277.4	548.9	16.7	268.4	583.4	14.5	0.0	595.0	12.8	0.0	532.9	65.6	0.0	783.1	506.4	1,370.5	11,022.3	10,407.9
2004	0.0	568.5	5.7	0.0	514.4	0.0	0.0	292.6	160.8	0.0	547.5	195.7	0.0	751.7	408.4	268.0	8,267.9	8,325.3
2005	664.2	818.0	89.5	642.8	681.1	28.1	0.0	542.7	104.5	0.0	621.5	140.7	1,521.0	1,741.0	2,132.8	8,116.7	18,223.3	18,273.9
2006	542.6	887.2	118.7	525.1	529.9	75.9	0.0	571.8	104.8	44.4	615.3	238.5	56.7	758.5	333.0	12,482.3	23,227.2	21,838.6
2007	0.0	517.5	23.1	0.0	495.8	43.0	0.0	351.4	10.3	0.0	544.4	50.1	0.0	419.4	115.3	0.0	6,319.4	6,300.8
2008	0.0	478.3	42.5	0.0	342.8	53.0	0.0	515.1	3.9	0.0	536.1	226.0	0.0	478.3	127.1	0.0	6,272.9	6,815.2
2009	83.1	579.6	54.7	80.4	422.7	26.5	0.0	442.6	66.7	0.0	471.5	49.4	0.0	572.8	178.6	410.0	10,582.0	10,344.7
2010	524.3	476.1	36.6	507.4	346.3	23.7	0.0	700.5	527.4	416.8	667.1	417.8	1,234.4	1,991.9	2,047.7	4,238.8	12,945.8	13,955.8

\* Unallocated water is simulated below Camanche and regulated and unimpaired flow is simulated at Mokelumne Hill.

**Table K-4: Presented as Table E-10: Unallocated, Regulated, and Natural Flow Comparison for January through July below Camanche (2040) (in TAF)\***  
Values shown provide flow in cubic feet per second (cfs) averaged over the monthly period indicated

	January			February			March			April			May			June			July		
	Unallocated	Regulated	Natural	Unallocated	Regulated	Natural	Unallocated	Regulated	Natural	Unallocated	Regulated	Natural	Unallocated	Regulated	Natural	Unallocated	Regulated	Natural	Unallocated	Regulated	Natural
1953	386.8	1,011.5	1,137.9	0.0	679.8	528.8	0.0	747.6	855.0	0.0	1,033.0	2,176.7	274.7	1,262.7	2,515.8	265.8	2,067.0	2,641.7	274.7	918.0	660.1
1954	0.0	635.1	431.9	0.0	629.2	618.5	0.0	940.6	1,470.8	0.0	1,219.2	2,626.1	0.0	1,471.7	2,720.6	0.0	705.3	707.1	0.0	539.8	223.3
1955	0.0	496.5	532.1	0.0	447.3	458.3	0.0	616.7	656.3	0.0	496.4	1,128.5	0.0	808.4	2,855.4	0.0	886.0	1,619.6	0.0	560.6	185.7
1956	2,749.0	2,971.2	3,441.7	868.2	1,640.0	1,289.2	93.3	1,586.5	1,301.7	3.0	1,619.9	1,959.0	1,805.6	3,191.1	4,581.2	1,003.8	3,270.4	3,408.9	615.8	856.1	701.8
1957	0.0	605.1	249.8	0.0	677.2	942.6	0.0	813.6	1,513.8	0.0	700.6	1,522.3	66.3	1,553.3	2,993.7	64.1	2,149.1	2,219.6	66.3	563.5	243.9
1958	0.0	797.9	431.4	700.4	1,329.4	1,446.7	772.0	1,563.2	1,725.3	1,556.3	2,368.9	3,275.1	2,139.0	3,341.8	5,860.1	1,086.9	3,574.8	3,691.5	705.3	1,029.0	875.1
1959	0.0	654.6	525.1	0.0	743.5	706.0	0.0	675.6	904.0	0.0	399.4	1,646.5	0.0	445.3	1,514.4	0.0	514.3	583.9	0.0	546.0	50.0
1960	0.0	340.8	139.1	0.0	567.8	829.3	0.0	516.3	1,266.5	0.0	518.0	1,757.0	0.0	961.6	2,042.8	0.0	897.8	698.1	0.0	522.5	61.7
1961	0.0	387.2	128.7	0.0	252.6	326.2	0.0	292.5	487.8	0.0	307.2	1,213.1	0.0	367.4	1,749.7	0.0	503.5	563.1	0.0	518.7	23.8
1962	0.0	344.3	146.7	0.0	908.5	1,216.8	0.0	843.4	832.6	0.0	1,450.3	2,905.2	0.0	1,151.1	2,727.1	0.0	2,183.8	2,329.1	0.0	654.5	281.7
1963	0.0	780.0	721.1	1,758.6	1,371.8	2,822.3	0.0	767.9	762.5	0.0	1,741.3	2,170.7	1,062.9	3,569.3	4,496.0	729.4	2,322.0	2,335.7	523.8	699.9	456.1
1964	0.0	781.4	413.7	0.0	616.6	367.9	0.0	564.6	526.3	0.0	529.6	1,418.3	0.0	541.7	2,413.6	0.0	562.3	1,165.7	0.0	607.8	147.0
1965	2,105.8	2,684.8	2,577.1	561.8	1,435.0	1,204.2	0.0	1,225.5	1,055.1	150.9	1,890.5	2,696.4	754.3	2,239.3	3,405.8	723.0	2,687.6	2,800.0	747.1	952.6	761.3
1966	21.2	682.4	390.7	0.0	388.7	380.5	0.0	701.8	1,153.7	0.0	858.7	2,264.0	0.0	771.9	2,105.1	0.0	453.9	750.9	0.0	554.2	72.8
1967	73.6	1,128.8	1,074.1	249.9	909.0	964.7	784.8	1,657.2	2,041.7	892.2	1,816.5	1,933.1	2,666.1	2,700.1	4,930.6	903.9	4,158.1	4,952.3	934.1	2,139.6	2,073.8
1968	0.0	651.3	334.6	0.0	763.9	1,204.0	0.0	759.7	1,037.3	0.0	627.5	1,452.7	0.0	499.5	1,924.6	0.0	630.4	596.7	0.0	516.7	65.2
1969	2,361.9	2,693.1	3,351.5	1,277.6	1,719.4	1,756.4	639.8	1,617.6	1,477.2	2,029.2	2,471.7	3,498.6	2,858.6	4,695.4	6,351.3	1,028.0	3,661.6	3,881.4	767.0	1,193.9	1,021.1
1970	3,226.6	2,693.0	4,029.4	687.8	1,404.2	1,340.0	247.7	1,660.8	1,416.9	0.0	1,124.9	1,260.9	156.8	1,921.2	3,108.1	151.7	1,996.2	1,952.5	156.8	759.1	306.0
1971	422.7	1,082.1	945.7	268.8	1,020.9	817.3	270.1	1,286.2	1,202.9	0.0	1,216.7	1,792.5	336.4	1,106.9	2,836.9	325.5	2,142.5	3,019.1	336.4	994.5	524.8
1972	0.0	609.6	339.1	0.0	494.8	543.9	0.0	954.4	1,661.3	0.0	815.0	1,333.7	0.0	659.3	2,667.3	0.0	1,187.3	1,126.4	0.0	636.7	115.9
1973	379.1	1,276.0	1,320.8	925.4	1,315.9	1,252.6	432.3	1,319.3	1,142.7	0.0	1,288.7	2,095.9	385.7	2,291.6	4,644.0	373.2	1,701.8	1,793.5	385.7	778.6	167.4
1974	1,110.2	1,515.4	1,881.3	0.0	1,055.9	622.2	594.3	1,958.4	2,032.5	400.1	1,902.2	2,345.0	760.2	2,330.2	4,156.0	617.3	2,337.7	2,471.8	637.9	1,033.0	592.5
1975	0.0	470.3	296.5	0.0	617.1	693.5	0.0	1,246.5	1,418.2	0.0	1,217.7	1,185.2	715.1	1,805.6	4,252.5	692.0	2,956.2	3,877.6	715.1	1,122.9	688.4
1976	0.0	468.3	165.5	0.0	224.2	229.6	0.0	271.5	467.4	0.0	280.2	735.9	0.0	308.0	1,192.7	0.0	281.8	130.6	0.0	284.7	23.0
1977	0.0	184.0	67.1	0.0	100.1	107.6	0.0	124.6	152.3	0.0	226.8	596.0	0.0	304.0	715.4	0.0	269.0	421.1	0.0	280.7	27.0
1978	0.0	1,199.5	1,471.3	0.0	1,089.3	1,017.9	0.0	1,610.8	2,147.4	0.0	1,891.8	2,529.4	98.1	1,882.9	3,950.0	94.9	3,174.6	3,580.3	98.1	1,122.8	839.6
1979	0.0	815.4	789.7	0.0	816.4	784.5	354.4	1,355.2	1,565.1	0.0	1,435.2	2,005.1	323.2	1,968.1	4,346.5	312.7	1,530.6	1,565.3	323.2	655.3	202.5
1980	2,884.6	2,779.6	4,122.8	2,041.0	2,553.1	2,783.7	267.3	1,896.2	1,646.6	0.0	1,448.7	2,205.1	818.9	2,213.8	3,372.7	694.3	2,836.9	2,911.7	717.4	1,308.9	1,134.3
1981	0.0	696.9	308.1	0.0	576.9	447.8	0.0	576.8	780.6	0.0	690.6	1,842.2	0.0	532.0	2,097.9	0.0	536.5	532.8	0.0	572.4	6.5
1982	1,289.7	1,817.5	1,697.3	2,551.1	2,759.9	3,426.1	1,625.1	2,599.6	2,556.3	3,269.7	4,070.4	5,036.3	2,458.8	4,769.9	5,214.4	909.0	3,021.0	3,096.3	939.3	1,309.8	921.7
1983	1,149.3	1,981.0	1,694.4	1,867.1	2,505.2	2,395.6	3,276.0	4,038.8	4,447.6	1,522.5	2,329.6	2,372.5	3,865.3	3,497.9	5,316.3	2,717.2	6,182.6	6,306.5	1,571.3	3,471.9	3,425.9
1984	1,260.2	1,899.2	1,451.9	599.6	1,466.0	934.4	112.3	1,606.3	1,411.0	0.0	1,330.4	1,437.4	400.2	2,413.6	3,615.2	387.3	1,823.2	1,646.0	400.2	977.3	294.0
1985	0.0	409.0	262.0	0.0	587.1	464.9	0.0	849.7	691.3	0.0	1,032.4	2,152.2	0.0	545.7	2,357.1	0.0	508.5	567.0	0.0	519.3	71.5
1986	0.0	877.6	1,144.9	4,328.1	4,421.5	5,649.6	2,587.4	3,193.5	4,312.4	112.5	2,076.0	2,361.3	1,261.8	3,222.3	3,554.9	479.7	2,211.6	2,367.3	495.7	761.1	406.8
1987	0.0	426.1	130.7	0.0	297.9	352.4	0.0	420.0	691.8	0.0	372.4	1,413.3	0.0	296.3	1,324.1	0.0	367.7	193.0	0.0	550.6	36.4
1988	0.0	367.6	296.5	0.0	247.2	333.3	0.0	291.3	689.2	0.0	320.8	1,123.3	0.0	390.2	1,133.8	0.0	457.2	375.6	0.0	480.1	61.9

**Table K-4: Presented as Table E-10: Unallocated, Regulated, and Natural Flow Comparison for January through July below Camanche (2040) (in TAF)\***  
Values shown provide flow in cubic feet per second (cfs) averaged over the monthly period indicated

	January			February			March			April			May			June			July		
	Unallocated	Regulated	Natural	Unallocated	Regulated	Natural	Unallocated	Regulated	Natural	Unallocated	Regulated	Natural	Unallocated	Regulated	Natural	Unallocated	Regulated	Natural	Unallocated	Regulated	Natural
1989	0.0	231.5	183.1	0.0	250.2	413.0	0.0	1,011.8	2,405.4	0.0	1,353.0	2,519.5	0.0	1,770.6	2,163.7	0.0	1,174.3	1,050.5	0.0	588.3	105.8
1990	0.0	552.9	287.7	0.0	378.3	307.1	0.0	552.6	982.3	0.0	405.3	1,620.0	0.0	554.7	1,197.6	0.0	575.7	563.5	0.0	553.6	60.2
1991	0.0	80.9	59.2	0.0	136.0	67.2	0.0	380.1	855.6	0.0	438.7	1,108.7	0.0	512.2	2,218.3	0.0	733.1	1,323.6	0.0	565.9	146.0
1992	0.0	387.7	167.1	0.0	486.1	690.8	0.0	661.9	893.1	0.0	408.3	1,785.3	0.0	360.9	944.7	0.0	309.9	140.6	0.0	513.3	146.1
1993	0.0	1,261.6	1,745.8	0.0	1,225.5	1,150.2	0.0	2,003.0	2,577.7	0.0	1,726.0	2,481.0	411.2	2,940.2	4,529.3	397.9	2,951.0	3,157.6	411.2	891.6	717.3
1994	0.0	345.5	165.1	0.0	269.7	286.9	0.0	312.6	722.0	0.0	293.9	1,294.2	0.0	370.2	1,563.9	0.0	488.8	462.4	0.0	399.3	36.0
1995	0.0	1,825.1	2,404.6	310.5	1,218.5	1,214.2	2,749.9	3,386.5	4,206.0	2,266.4	2,728.3	3,135.1	3,938.9	4,159.5	5,516.9	1,385.4	5,026.4	5,265.0	1,202.7	3,035.6	3,234.1
1996	0.0	740.7	908.6	1,750.2	1,896.2	2,753.8	852.8	2,157.7	2,187.3	130.0	1,977.1	2,537.8	1,450.7	3,785.6	4,313.2	368.1	1,892.7	1,946.4	380.3	759.4	415.5
1997	5,939.4	5,790.2	7,348.6	1,222.6	1,869.2	1,445.0	187.6	1,574.0	1,411.8	0.0	1,580.3	2,063.8	113.3	2,460.3	2,903.7	109.6	1,360.4	1,158.8	113.3	660.6	185.9
1998	342.6	1,038.6	1,370.6	1,739.7	2,053.2	2,342.7	1,093.3	2,112.3	2,650.9	1,438.9	2,057.8	2,642.5	2,240.2	2,683.3	3,704.9	1,143.9	4,694.5	5,797.6	1,028.3	2,247.8	2,286.5
1999	287.3	1,148.3	1,016.4	1,480.0	1,990.0	2,172.9	457.0	1,505.9	1,383.3	0.0	1,448.2	1,867.7	587.9	2,055.4	4,062.9	666.1	2,575.1	2,755.4	555.2	994.4	470.5
2000	0.0	847.0	1,032.6	708.2	1,374.5	1,882.1	421.8	1,562.4	1,589.0	0.0	1,132.7	2,233.9	203.3	2,133.0	3,439.5	196.7	1,384.1	1,148.2	203.3	855.6	164.9
2001	0.0	327.9	212.4	0.0	301.8	347.2	0.0	633.5	1,061.2	0.0	896.7	1,488.7	0.0	742.0	2,329.1	0.0	539.3	203.4	0.0	572.3	67.2
2002	0.0	897.6	722.5	0.0	605.7	611.3	0.0	1,158.2	1,099.0	0.0	1,097.6	2,190.9	0.0	889.3	2,674.6	0.0	1,019.6	1,039.7	0.0	531.5	170.3
2003	0.0	948.9	633.9	0.0	825.2	550.9	0.0	799.7	946.6	0.0	992.2	1,603.1	47.8	1,758.0	3,592.1	46.3	2,055.2	2,196.7	47.8	599.8	268.5
2004	0.0	859.7	378.4	0.0	832.0	812.9	148.8	1,306.8	1,843.6	0.0	785.9	2,018.2	0.0	473.1	1,926.8	0.0	793.7	500.3	0.0	542.2	74.6
2005	0.0	1,392.7	1,200.9	197.1	1,300.5	1,081.3	1,097.0	2,055.3	1,968.6	463.9	2,027.2	2,084.3	1,507.2	3,006.3	5,317.4	806.1	2,817.1	3,298.9	571.5	1,219.9	827.0
2006	1,471.0	1,824.8	2,353.4	804.9	1,325.7	1,591.1	1,066.7	2,650.9	2,182.4	3,807.5	4,846.6	5,190.4	2,357.5	4,874.6	5,916.9	995.3	3,170.1	3,182.1	446.6	1,172.0	551.3
2007	0.0	544.0	301.9	0.0	593.4	891.9	0.0	774.9	1,237.1	0.0	481.5	1,638.7	0.0	590.3	1,590.0	0.0	472.1	286.5	0.0	534.9	113.0
2008	0.0	493.9	368.0	0.0	512.3	463.3	0.0	771.2	840.5	0.0	479.5	1,373.9	0.0	672.0	2,374.6	0.0	589.7	849.2	0.0	403.6	93.2
2009	0.0	696.4	527.5	0.0	638.5	751.7	0.0	1,325.1	1,710.6	0.0	1,159.1	1,883.5	0.0	2,653.6	4,035.4	0.0	958.5	898.2	0.0	661.6	161.9
2010	0.0	759.0	443.4	0.0	707.6	514.3	0.0	984.9	974.8	0.0	1,355.0	1,723.8	377.3	1,941.7	2,830.2	365.1	2,207.3	3,910.8	377.3	808.3	505.2

\* Unallocated water is simulated below Camanche and regulated and unimpaired flow is simulated at Mokelumne Hill.



**Table K-5: Presented as Table E-11: Unallocated, Regulated, and Natural Flow Comparison for August through December below Camanche (2040) (in TAF)\***  
**Values shown provide flow in cubic feet per second (cfs) averaged over the monthly period indicated**

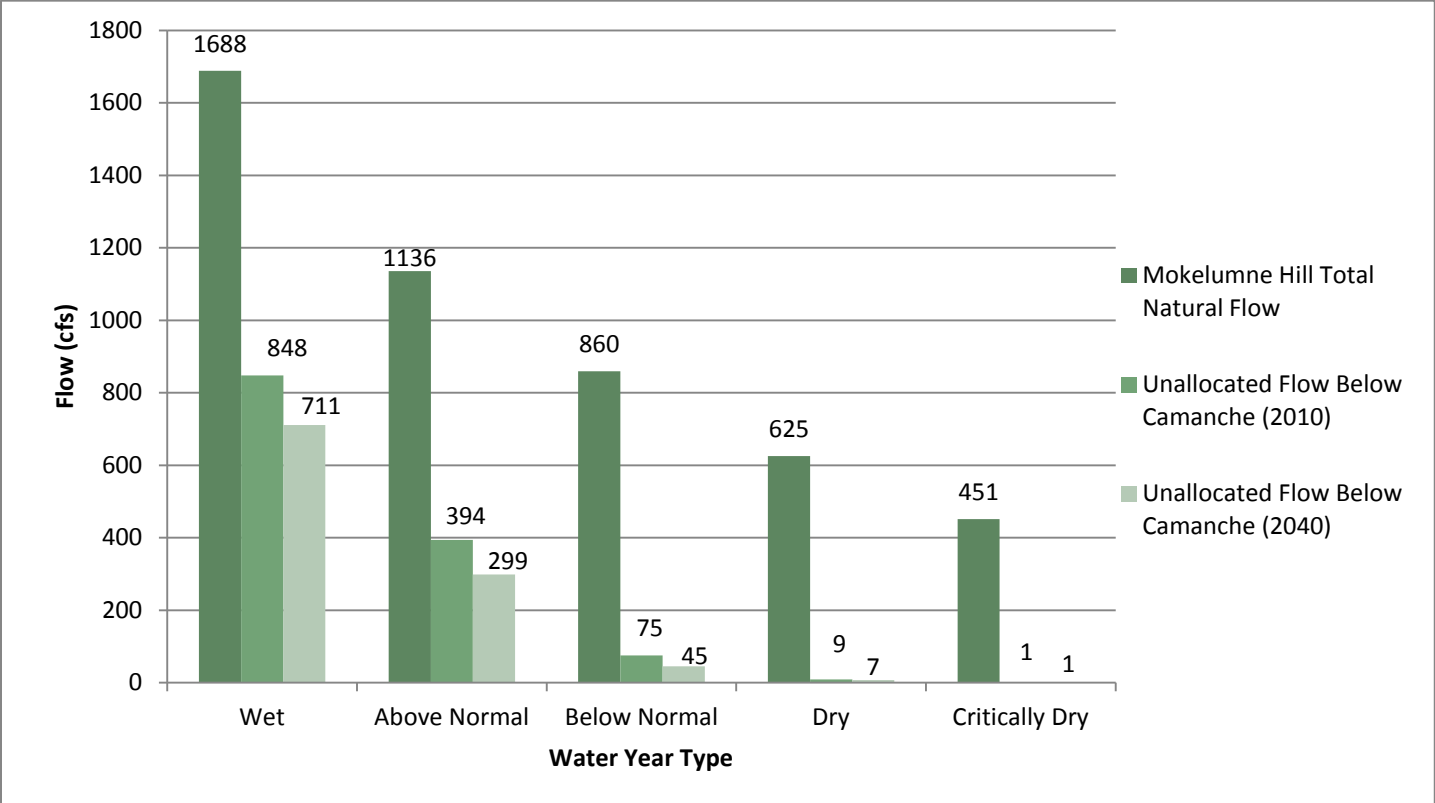
	August			September			October			November			December			Total		
	Unallocated	Regulated	Natural	Unallocated	Regulated	Natural	Unallocated	Regulated	Natural	Unallocated	Regulated	Natural	Unallocated	Regulated	Natural	Unallocated	Regulated	Natural
1953	274.7	622.5	66.6	265.8	630.7	37.2	0.0	699.3	94.4	0.0	652.7	188.7	0.0	630.9	244.5	1,742.3	10,955.6	11,147.5
1954	0.0	578.8	0.0	0.0	610.5	38.6	0.0	633.0	67.5	0.0	681.0	131.0	0.0	575.2	474.7	0.0	9,219.4	9,510.1
1955	0.0	571.6	45.9	0.0	541.3	15.0	0.0	559.3	39.5	0.0	560.9	96.2	1,794.7	2,710.2	4,312.9	1,794.7	9,255.1	11,945.4
1956	615.8	614.4	108.7	596.0	570.5	72.8	0.0	665.3	151.0	0.0	714.6	177.9	0.0	751.0	219.5	8,350.4	18,451.1	17,413.3
1957	66.3	523.2	40.0	64.1	537.6	38.9	0.0	660.8	67.2	0.0	723.3	119.6	0.0	723.0	267.1	327.2	10,230.4	10,218.4
1958	705.3	745.6	144.6	682.5	595.4	61.5	0.0	664.2	65.1	0.0	636.5	92.0	0.0	561.8	82.2	8,347.7	17,208.5	17,750.5
1959	0.0	543.3	2.4	0.0	513.1	77.0	0.0	541.4	36.9	0.0	507.8	31.8	0.0	534.7	54.0	0.0	6,619.0	6,132.2
1960	0.0	528.1	0.0	0.0	510.6	17.3	0.0	516.6	8.2	0.0	500.2	110.2	0.0	529.4	179.2	0.0	6,909.6	7,109.5
1961	0.0	500.0	0.0	0.0	500.5	4.2	0.0	514.4	6.6	0.0	317.0	63.0	0.0	311.7	172.1	0.0	4,772.5	4,738.2
1962	0.0	618.7	39.3	0.0	568.8	0.4	0.0	669.4	331.9	0.0	627.5	113.2	0.0	629.0	307.4	0.0	10,649.3	11,231.7
1963	523.8	645.4	47.2	506.9	607.1	56.4	0.0	633.6	115.7	356.9	691.8	770.7	0.0	725.1	397.5	5,462.2	14,555.2	15,151.7
1964	0.0	585.8	34.0	0.0	575.2	40.7	0.0	609.6	73.2	0.0	711.4	259.0	3,209.5	3,365.5	5,237.0	3,209.5	10,051.5	12,096.4
1965	747.1	753.3	346.9	723.0	931.2	115.9	0.0	931.4	88.4	293.3	946.1	440.4	22.1	771.4	363.1	6,828.3	17,448.6	15,854.4
1966	0.0	557.6	17.3	0.0	601.7	30.9	0.0	554.2	24.5	0.0	668.2	292.8	0.0	1,191.3	1,199.4	21.2	7,984.7	8,682.5
1967	934.1	672.7	231.6	903.9	639.6	87.2	0.0	658.0	89.0	0.0	662.8	118.0	0.0	667.7	183.2	8,342.7	17,810.1	18,679.3
1968	0.0	525.3	42.1	0.0	537.7	16.8	0.0	543.8	75.6	0.0	665.3	572.9	0.0	739.7	396.6	0.0	7,460.7	7,719.0
1969	767.0	830.3	116.4	742.3	776.0	62.1	0.0	804.8	184.3	0.0	659.2	195.2	115.3	910.4	1,090.2	12,586.6	22,033.4	22,985.8
1970	156.8	589.5	64.1	151.7	567.9	5.8	0.0	608.1	47.6	334.7	871.3	516.4	519.3	1,237.0	893.6	5,790.1	15,433.1	14,941.3
1971	336.4	905.1	55.9	325.5	688.6	9.0	0.0	736.2	52.7	56.2	552.0	200.4	97.7	688.4	494.9	2,775.8	12,420.1	11,952.2
1972	0.0	567.0	15.4	0.0	561.9	15.5	0.0	622.2	72.3	0.0	659.0	187.8	0.0	764.6	641.0	0.0	8,531.8	8,719.6
1973	385.7	575.2	25.7	373.2	576.9	0.2	0.0	643.3	105.3	1,044.6	911.3	1,421.1	626.0	1,261.2	1,225.1	5,311.0	13,939.7	15,194.5
1974	637.9	937.0	96.6	617.3	740.6	14.9	0.0	594.7	51.8	0.0	509.2	87.1	0.0	547.0	188.0	5,375.2	15,461.3	14,539.6
1975	715.1	925.4	123.4	692.0	878.5	48.4	0.0	760.0	363.6	52.0	690.6	380.7	0.0	647.6	199.2	3,581.4	13,338.5	13,527.3
1976	0.0	295.5	71.2	0.0	285.5	35.8	0.0	204.8	32.9	0.0	203.1	41.3	0.0	150.8	31.8	0.0	3,258.2	3,157.6
1977	0.0	273.0	22.7	0.0	291.1	22.5	0.0	18.4	13.7	0.0	48.5	57.2	0.0	393.1	489.7	0.0	2,513.4	2,692.5
1978	98.1	880.0	62.2	94.9	675.7	225.5	0.0	611.7	35.9	0.0	570.5	86.8	0.0	524.9	145.6	484.2	15,234.6	16,091.7
1979	323.2	599.4	52.1	312.7	531.6	3.0	0.0	578.5	149.5	0.0	646.0	300.0	0.0	804.0	330.5	1,949.3	11,735.8	12,093.9
1980	717.4	611.1	123.4	694.3	574.5	48.8	0.0	586.1	41.0	0.0	552.2	49.2	0.0	629.5	134.2	8,835.2	17,990.6	18,573.6
1981	0.0	475.2	8.5	0.0	499.6	8.8	0.0	581.7	92.6	0.0	747.0	1,297.8	1,200.1	1,385.0	2,201.5	1,200.1	7,870.5	9,625.0
1982	939.3	919.7	131.9	909.0	714.7	226.9	0.0	788.0	1,124.8	1,077.7	1,385.4	1,025.2	1,482.2	2,025.4	1,811.9	17,450.7	26,181.2	26,269.2
1983	1,571.3	1,162.5	514.4	1,520.6	956.9	279.6	0.0	931.6	173.3	2,005.8	1,928.6	2,658.5	2,487.9	2,980.2	3,126.9	23,554.0	31,966.7	32,711.3
1984	400.2	832.6	59.0	387.3	587.4	21.7	0.0	647.9	78.0	250.5	768.2	516.6	0.0	716.5	275.1	4,197.9	15,068.5	11,740.3
1985	0.0	573.4	24.5	0.0	565.3	44.4	0.0	616.3	31.9	0.0	657.5	195.6	0.0	659.9	419.1	0.0	7,524.0	7,281.3
1986	495.7	641.7	111.7	479.7	617.8	32.5	0.0	629.9	26.5	0.0	627.4	27.3	0.0	552.4	58.0	10,240.8	19,832.9	20,053.2
1987	0.0	536.2	11.7	0.0	475.1	11.2	0.0	250.8	29.9	0.0	229.1	33.8	0.0	302.4	58.0	0.0	4,524.5	4,286.3
1988	0.0	402.5	13.1	0.0	350.3	10.9	0.0	236.9	3.4	0.0	220.6	157.8	0.0	227.1	156.3	0.0	3,991.8	4,355.1

**Table K-5: Presented as Table E-11: Unallocated, Regulated, and Natural Flow Comparison for August through December below Camanche (2040) (in TAF)\***  
 Values shown provide flow in cubic feet per second (cfs) averaged over the monthly period indicated

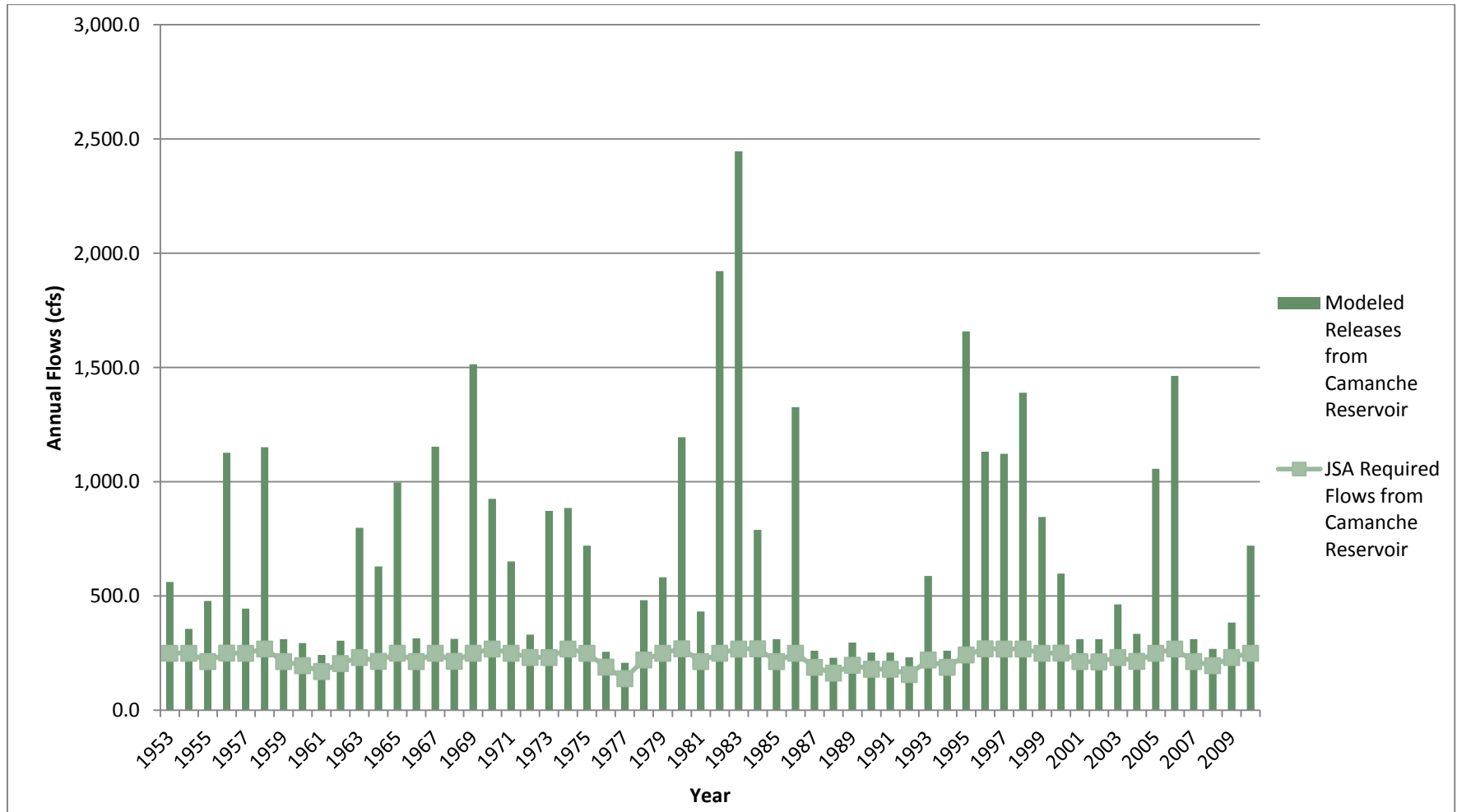
	August			September			October			November			December			Total		
	Unallocated	Regulated	Natural	Unallocated	Regulated	Natural	Unallocated	Regulated	Natural	Unallocated	Regulated	Natural	Unallocated	Regulated	Natural	Unallocated	Regulated	Natural
1989	0.0	535.1	29.7	0.0	560.3	61.1	0.0	400.6	168.6	0.0	612.5	211.9	0.0	590.6	170.4	0.0	9,078.8	9,482.7
1990	0.0	492.9	16.4	0.0	479.7	6.8	0.0	538.4	6.1	0.0	154.3	15.7	0.0	204.2	52.2	0.0	5,442.7	5,115.8
1991	0.0	495.5	32.9	0.0	494.8	0.0	0.0	553.4	94.0	0.0	566.2	143.2	0.0	521.4	144.8	0.0	5,478.0	6,193.5
1992	0.0	500.9	19.7	0.0	337.7	36.0	0.0	332.6	36.8	0.0	255.0	89.3	0.0	408.3	310.9	0.0	4,962.7	5,260.4
1993	411.2	900.2	162.9	397.9	587.7	66.6	0.0	673.9	72.1	0.0	532.9	43.6	0.0	537.9	67.5	2,029.5	16,231.6	16,771.6
1994	0.0	440.7	21.8	0.0	553.5	18.7	0.0	555.0	48.2	0.0	240.2	251.9	0.0	546.6	340.8	0.0	4,815.8	5,211.9
1995	1,202.7	847.0	504.7	1,163.9	786.0	124.9	0.0	842.4	78.0	0.0	564.7	73.2	0.0	607.5	519.6	14,220.4	25,027.7	26,276.4
1996	380.3	741.6	100.7	368.1	577.9	39.1	0.0	553.1	0.0	275.4	884.2	670.3	2,122.5	2,349.0	2,685.3	8,078.3	18,315.2	18,558.1
1997	113.3	689.3	75.8	109.6	614.0	54.8	0.0	660.6	37.0	144.9	695.5	147.7	0.0	467.0	191.9	8,053.7	18,421.5	17,024.9
1998	1,028.3	976.6	264.3	995.1	832.0	134.0	0.0	709.9	125.0	0.0	696.0	293.4	0.0	819.8	422.3	11,050.1	20,921.8	22,034.5
1999	555.2	691.1	126.8	537.3	628.1	58.0	0.0	588.8	26.6	0.0	660.6	164.2	0.0	574.3	138.0	5,126.0	14,860.1	14,242.6
2000	203.3	722.1	27.3	196.7	552.1	68.9	0.0	575.8	86.8	0.0	604.9	103.8	0.0	578.0	93.1	2,133.4	12,322.1	11,870.0
2001	0.0	532.2	38.2	0.0	466.8	60.0	0.0	427.1	0.0	0.0	336.6	232.0	0.0	617.1	542.0	0.0	6,393.4	6,581.5
2002	0.0	523.6	28.6	0.0	497.9	0.0	0.0	531.0	19.8	0.0	567.6	332.1	0.0	677.6	376.5	0.0	8,997.2	9,265.2
2003	47.8	548.9	16.7	46.3	583.4	14.5	0.0	595.0	12.8	0.0	532.9	65.6	0.0	783.1	506.4	236.1	11,022.3	10,407.9
2004	0.0	568.5	5.7	0.0	514.4	0.0	0.0	292.6	160.8	0.0	547.5	195.7	0.0	751.7	408.4	148.8	8,267.9	8,325.3
2005	571.5	818.0	89.5	553.1	681.1	28.1	0.0	542.7	104.5	0.0	621.5	140.7	1,471.7	1,741.0	2,132.8	7,239.2	18,223.3	18,273.9
2006	446.6	887.2	118.7	432.2	529.9	75.9	0.0	571.8	104.8	19.4	615.3	238.5	32.5	758.5	333.0	11,880.1	23,227.2	21,838.6
2007	0.0	517.5	23.1	0.0	495.8	43.0	0.0	351.4	10.3	0.0	544.4	50.1	0.0	419.4	115.3	0.0	6,319.4	6,300.8
2008	0.0	478.3	42.5	0.0	342.8	53.0	0.0	515.1	3.9	0.0	536.1	226.0	0.0	478.3	127.1	0.0	6,272.9	6,815.2
2009	0.0	579.6	54.7	0.0	422.7	26.5	0.0	442.6	66.7	0.0	471.5	49.4	0.0	572.8	178.6	0.0	10,582.0	10,344.7
2010	377.3	476.1	36.6	365.1	346.3	23.7	0.0	700.5	527.4	391.8	667.1	417.8	1,210.3	1,991.9	2,047.7	3,464.0	12,945.8	13,955.8

\* Unallocated water is simulated below Camanche and regulated and unimpaired flow is simulated at Mokelumne Hill.

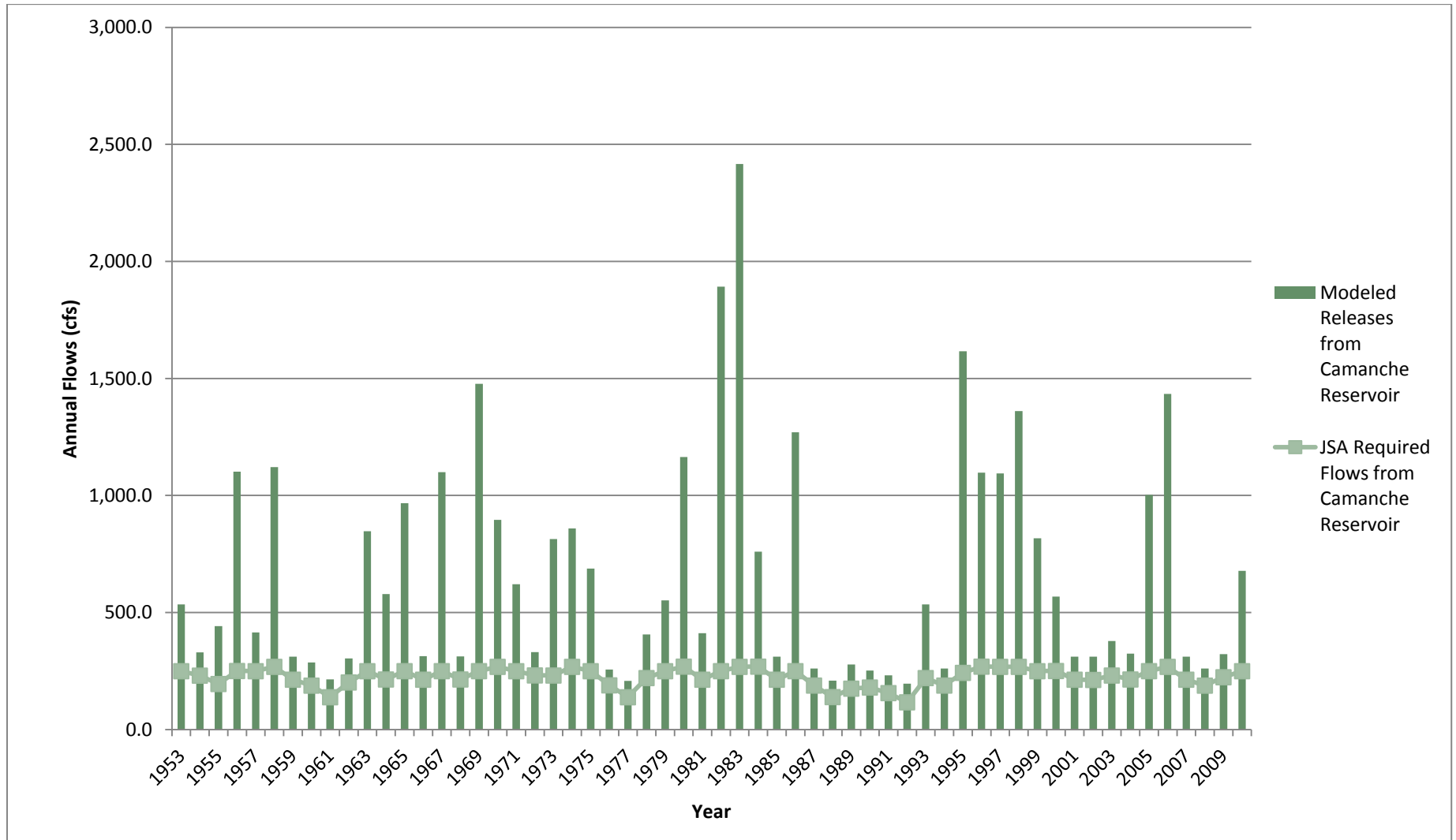
**Figure K-1: Presented as Figure F-1: Average Total Natural Flow at Mokelumne Hill Compared to Unallocated Flow below Camanche in 2010 and 2040 Baseline Conditions by Water Year Type (in TAF)**  
**Values shown provide flow in cubic feet per second (cfs) averaged over the water year type indicated**



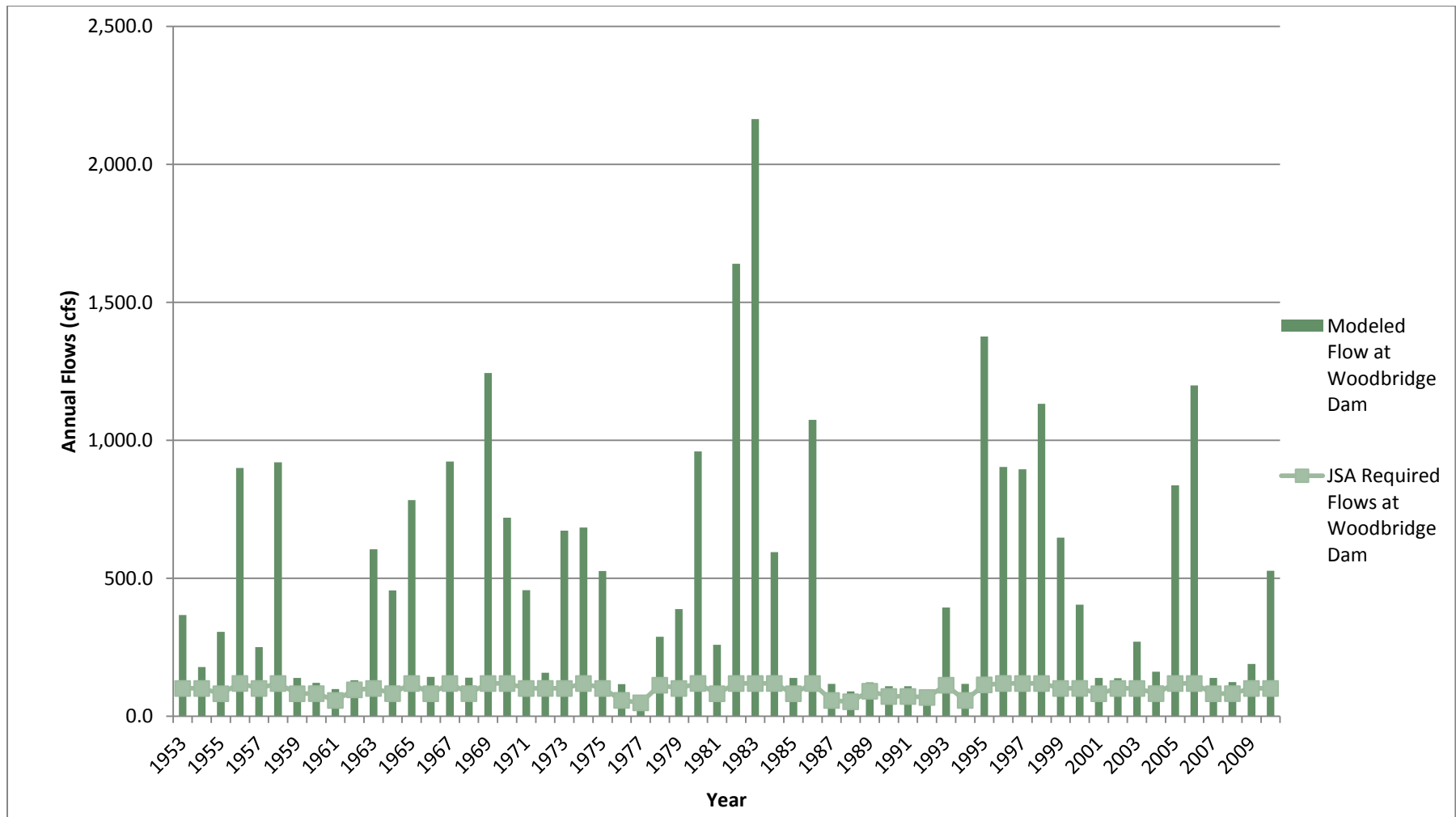
**Figure K-2: Presented as Figure G-1: Required and Modeled Annual Flows for the 2010 Base Case from Camanche Reservoir**  
Values shown provide flow in cubic feet per second (cfs) averaged over the yearly period indicated



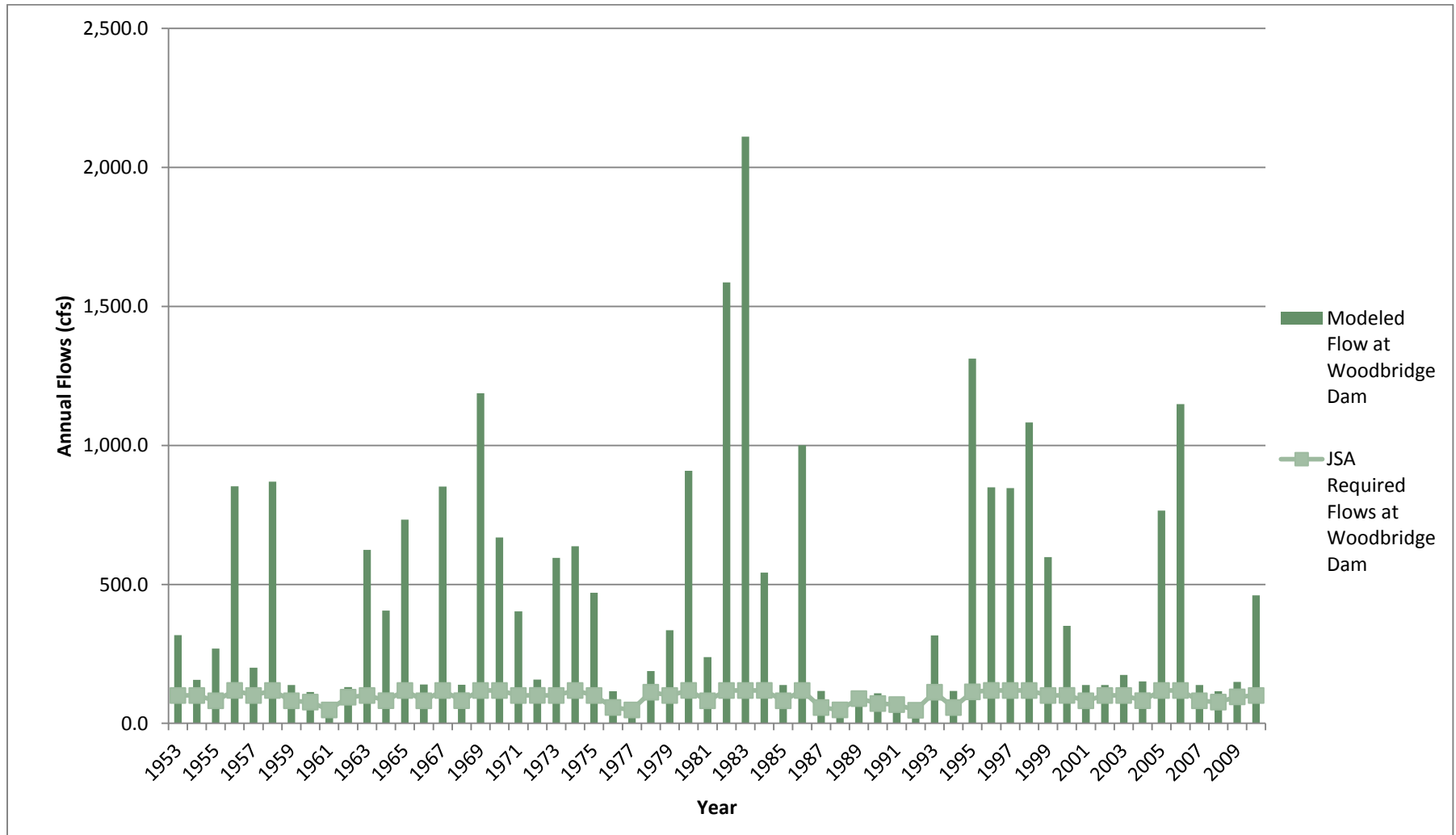
**Figure K-3: Presented as Figure G-2: Required and Modeled Annual Flows for the 2040 Base Case from Camanche Reservoir**  
Values shown provide flow in cubic feet per second (cfs) averaged over the yearly period indicated



**Figure K-4: Presented as Figure G-3: Required and Modeled Annual Flows  
for the 2010 Base Case from Woodbridge Dam**  
Values shown provide flow in cubic feet per second (cfs) averaged over the yearly period indicated



**Figure K-5: Presented as Figure G-4: Required and Modeled Annual Flows for the 2040 Base Case from Woodbridge Dam**  
Values shown provide flow in cubic feet per second (cfs) averaged over the yearly period indicated



**Table K-6: Presented as Table I-1: Riparian Diversions Above Highway 99\***  
Values shown provide flow in cubic feet per second (cfs) averaged over the monthly period indicated

	Jan	Feb	Mar	Apr	May	Jun	Jul	Aug	Sep	Oct	Nov	Dec	Total
1953	1.6	1.4	4.3	14.1	35.6	50.7	49.6	32.4	16.2	7.6	3.2	5.8	222.5
1954	1.6	1.4	4.3	14.1	35.6	50.7	49.6	32.4	16.2	7.6	3.2	5.8	222.5
1955	1.6	1.4	4.3	14.1	35.6	50.7	49.6	32.4	16.2	7.6	3.2	5.8	222.5
1956	1.6	1.4	4.3	14.1	35.6	50.7	49.6	32.4	16.2	7.6	3.2	5.8	222.5
1957	1.6	1.4	4.3	14.1	35.6	50.7	49.6	32.4	16.2	7.6	3.2	5.8	222.5
1958	1.6	1.4	4.3	14.1	35.6	50.7	49.6	32.4	16.2	7.6	3.2	5.8	222.5
1959	1.6	1.4	4.3	14.1	35.6	50.7	49.6	32.4	16.2	7.6	3.2	5.8	222.5
1960	1.6	1.4	4.3	14.1	35.6	50.7	49.6	32.4	16.2	7.6	3.2	5.8	222.5
1961	1.6	1.4	4.3	14.1	35.6	50.7	49.6	32.4	16.2	7.6	3.2	5.8	222.5
1962	1.6	1.4	4.3	14.1	35.6	50.7	49.6	32.4	16.2	7.6	3.2	5.8	222.5
1963	1.6	1.4	4.3	14.1	35.6	50.7	49.6	32.4	16.2	7.6	3.2	5.8	222.5
1964	1.6	1.4	4.3	14.1	35.6	50.7	49.6	32.4	16.2	7.6	3.2	5.8	222.5
1965	1.6	1.4	4.3	14.1	35.6	50.7	49.6	32.4	16.2	7.6	3.2	5.8	222.5
1966	1.6	1.4	4.3	14.1	35.6	50.7	49.6	32.4	16.2	7.6	3.2	5.8	222.5
1967	1.6	1.4	4.3	14.1	35.6	50.7	49.6	32.4	16.2	7.6	3.2	5.8	222.5
1968	1.6	1.4	4.3	14.1	35.6	50.7	49.6	32.4	16.2	7.6	3.2	5.8	222.5
1969	1.6	1.4	4.3	14.1	35.6	50.7	49.6	32.4	16.2	7.6	3.2	5.8	222.5
1970	1.6	1.4	4.3	14.1	35.6	50.7	49.6	32.4	16.2	7.6	3.2	5.8	222.5
1971	1.6	1.4	4.3	14.1	35.6	50.7	49.6	32.4	16.2	7.6	3.2	5.8	222.5
1972	1.6	1.4	4.3	14.1	35.6	50.7	49.6	32.4	16.2	7.6	3.2	5.8	222.5
1973	1.6	1.4	4.3	14.1	35.6	50.7	49.6	32.4	16.2	7.6	3.2	5.8	222.5
1974	1.6	1.4	4.3	14.1	35.6	50.7	49.6	32.4	16.2	7.6	3.2	5.8	222.5
1975	1.6	1.4	4.3	14.1	35.6	50.7	49.6	32.4	16.2	7.6	3.2	5.8	222.5
1976	1.6	1.4	4.3	14.0	35.6	50.7	24.8	16.2	8.1	7.6	3.2	5.8	173.4
1977	1.6	1.4	4.3	14.0	35.6	50.7	24.8	16.2	8.1	7.6	3.2	5.8	173.3
1978	1.6	1.4	4.3	14.1	35.6	50.7	49.6	32.4	16.2	7.6	3.2	5.8	222.5
1979	1.6	1.4	4.3	14.1	35.6	50.7	49.6	32.4	16.2	7.6	3.2	5.8	222.5
1980	1.6	1.4	4.3	14.1	35.6	50.7	49.6	32.4	16.2	7.6	3.2	5.8	222.5
1981	1.6	1.4	4.3	14.1	35.6	50.7	49.6	32.4	16.2	7.6	3.2	5.8	222.5
1982	1.6	1.4	4.3	14.1	35.6	50.7	49.6	32.4	16.2	7.6	3.2	5.8	222.5
1983	1.6	1.4	4.3	14.1	35.6	50.7	49.6	32.4	16.2	7.6	3.2	5.8	222.5



**Table K-6: Presented as Table I-1: Riparian Diversions Above Highway 99\***  
**Values shown provide flow in cubic feet per second (cfs) averaged over the monthly period indicated**

	<b>Jan</b>	<b>Feb</b>	<b>Mar</b>	<b>Apr</b>	<b>May</b>	<b>Jun</b>	<b>Jul</b>	<b>Aug</b>	<b>Sep</b>	<b>Oct</b>	<b>Nov</b>	<b>Dec</b>	<b>Total</b>
<b>1984</b>	1.6	1.4	4.3	14.1	35.6	50.7	49.6	32.4	16.2	7.6	3.2	5.8	222.5
<b>1985</b>	1.6	1.4	4.3	14.1	35.6	50.7	49.6	32.4	16.2	7.6	3.2	5.8	222.5
<b>1986</b>	1.6	1.4	4.3	14.1	35.6	50.7	49.6	32.4	16.2	7.6	3.2	5.8	222.5
<b>1987</b>	1.6	1.4	4.3	14.1	35.6	50.7	49.6	32.4	16.2	7.6	3.2	5.8	222.5
<b>1988</b>	1.6	1.4	4.3	14.0	35.6	50.7	24.8	16.2	8.1	7.6	3.2	5.8	173.3
<b>1989</b>	1.6	1.4	4.3	14.1	35.6	50.7	49.6	32.4	16.2	7.6	3.2	5.8	222.5
<b>1990</b>	1.6	1.4	4.3	14.1	35.6	50.7	49.6	32.4	16.2	7.6	3.2	5.8	222.5
<b>1991</b>	1.6	1.4	4.3	14.1	35.6	50.7	49.6	32.4	16.2	7.6	3.2	5.8	222.5
<b>1992</b>	1.6	1.4	4.3	14.1	35.6	50.7	49.6	32.4	16.2	7.6	3.2	5.8	222.5
<b>1993</b>	1.6	1.4	4.3	14.1	35.6	50.7	49.6	32.4	16.2	7.6	3.2	5.8	222.5
<b>1994</b>	1.6	1.4	4.3	14.1	35.6	50.7	49.6	32.4	16.2	7.6	3.2	5.8	222.5
<b>1995</b>	1.6	1.4	4.3	14.1	35.6	50.7	49.6	32.4	16.2	7.6	3.2	5.8	222.5
<b>1996</b>	1.6	1.4	4.3	14.1	35.6	50.7	49.6	32.4	16.2	7.6	3.2	5.8	222.5
<b>1997</b>	1.6	1.4	4.3	14.1	35.6	50.7	49.6	32.4	16.2	7.6	3.2	5.8	222.5
<b>1998</b>	1.6	1.4	4.3	14.1	35.6	50.7	49.6	32.4	16.2	7.6	3.2	5.8	222.5
<b>1999</b>	1.6	1.4	4.3	14.1	35.6	50.7	49.6	32.4	16.2	7.6	3.2	5.8	222.5
<b>2000</b>	1.6	1.4	4.3	14.1	35.6	50.7	49.6	32.4	16.2	7.6	3.2	5.8	222.5
<b>2001</b>	1.6	1.4	4.3	14.1	35.6	50.7	49.6	32.4	16.2	7.6	3.2	5.8	222.5
<b>2002</b>	1.6	1.4	4.3	14.1	35.6	50.7	49.6	32.4	16.2	7.6	3.2	5.8	222.5
<b>2003</b>	1.6	1.4	4.3	14.1	35.6	50.7	49.6	32.4	16.2	7.6	3.2	5.8	222.5
<b>2004</b>	1.6	1.4	4.3	14.1	35.6	50.7	49.6	32.4	16.2	7.6	3.2	5.8	222.5
<b>2005</b>	1.6	1.4	4.3	14.1	35.6	50.7	49.6	32.4	16.2	7.6	3.2	5.8	222.5
<b>2006</b>	1.6	1.4	4.3	14.1	35.6	50.7	49.6	32.4	16.2	7.6	3.2	5.8	222.5
<b>2007</b>	1.6	1.4	4.3	14.1	35.6	50.7	49.6	32.4	16.2	7.6	3.2	5.8	222.5
<b>2008</b>	1.6	1.4	4.3	14.1	35.6	50.7	49.6	32.4	16.2	7.6	3.2	5.8	222.5
<b>2009</b>	1.6	1.4	4.3	14.1	35.6	50.7	49.6	32.4	16.2	7.6	3.2	5.8	222.5
<b>2010</b>	1.6	1.4	4.3	14.1	35.6	50.7	49.6	32.4	16.2	7.6	3.2	5.8	222.5
<b>Ave</b>	0.1	0.1	0.3	0.8	2.1	3.1	2.9	1.9	0.9	0.5	0.2	0.3	13.2
<b>Max</b>	0.1	0.1	0.3	0.8	2.1	3.1	3.0	2.0	1.0	0.5	0.2	0.4	13.4
<b>Min</b>	0.1	0.1	0.3	0.8	2.1	3.1	1.5	1.0	0.5	0.5	0.2	0.3	10.4

\*Note: Riparian diversions are the same for both the 2010 and 2040 baseline cases.

**Table K-7: Presented as Table I-2: Riparian Diversions Above Woodbridge Diversion Dam\***  
Values shown provide flow in cubic feet per second (cfs) averaged over the monthly period indicated

	Jan	Feb	Mar	Apr	May	Jun	Jul	Aug	Sep	Oct	Nov	Dec	Total
1953	0.1	0.1	0.3	1.1	2.7	3.9	3.8	2.5	1.2	0.6	0.2	0.4	17.1
1954	0.1	0.1	0.3	1.1	2.7	3.9	3.8	2.5	1.2	0.6	0.2	0.4	17.1
1955	0.1	0.1	0.3	1.1	2.7	3.9	3.8	2.5	1.2	0.6	0.2	0.4	17.1
1956	0.1	0.1	0.3	1.1	2.7	3.9	3.8	2.5	1.2	0.6	0.2	0.4	17.1
1957	0.1	0.1	0.3	1.1	2.7	3.9	3.8	2.5	1.2	0.6	0.2	0.4	17.1
1958	0.1	0.1	0.3	1.1	2.7	3.9	3.8	2.5	1.2	0.6	0.2	0.4	17.1
1959	0.1	0.1	0.3	1.1	2.7	3.9	3.8	2.5	1.2	0.6	0.2	0.4	17.1
1960	0.1	0.1	0.3	1.1	2.7	3.9	3.8	2.5	1.2	0.6	0.2	0.4	17.1
1961	0.1	0.1	0.3	1.1	2.7	3.9	3.8	2.5	1.2	0.6	0.2	0.4	17.1
1962	0.1	0.1	0.3	1.1	2.7	3.9	3.8	2.5	1.2	0.6	0.2	0.4	17.1
1963	0.1	0.1	0.3	1.1	2.7	3.9	3.8	2.5	1.2	0.6	0.2	0.4	17.1
1964	0.1	0.1	0.3	1.1	2.7	3.9	3.8	2.5	1.2	0.6	0.2	0.4	17.1
1965	0.1	0.1	0.3	1.1	2.7	3.9	3.8	2.5	1.2	0.6	0.2	0.4	17.1
1966	0.1	0.1	0.3	1.1	2.7	3.9	3.8	2.5	1.2	0.6	0.2	0.4	17.1
1967	0.1	0.1	0.3	1.1	2.7	3.9	3.8	2.5	1.2	0.6	0.2	0.4	17.1
1968	0.1	0.1	0.3	1.1	2.7	3.9	3.8	2.5	1.2	0.6	0.2	0.4	17.1
1969	0.1	0.1	0.3	1.1	2.7	3.9	3.8	2.5	1.2	0.6	0.2	0.4	17.1
1970	0.1	0.1	0.3	1.1	2.7	3.9	3.8	2.5	1.2	0.6	0.2	0.4	17.1
1971	0.1	0.1	0.3	1.1	2.7	3.9	3.8	2.5	1.2	0.6	0.2	0.4	17.1
1972	0.1	0.1	0.3	1.1	2.7	3.9	3.8	2.5	1.2	0.6	0.2	0.4	17.1
1973	0.1	0.1	0.3	1.1	2.7	3.9	3.8	2.5	1.2	0.6	0.2	0.4	17.1
1974	0.1	0.1	0.3	1.1	2.7	3.9	3.8	2.5	1.2	0.6	0.2	0.4	17.1
1975	0.1	0.1	0.3	1.1	2.7	3.9	3.8	2.5	1.2	0.6	0.2	0.4	17.1
1976	0.1	0.1	0.3	1.1	2.7	3.9	1.9	1.2	0.6	0.6	0.2	0.4	13.3
1977	0.1	0.1	0.3	1.1	2.7	3.9	1.9	1.2	0.6	0.6	0.2	0.4	13.3
1978	0.1	0.1	0.3	1.1	2.7	3.9	3.8	2.5	1.2	0.6	0.2	0.4	17.1
1979	0.1	0.1	0.3	1.1	2.7	3.9	3.8	2.5	1.2	0.6	0.2	0.4	17.1
1980	0.1	0.1	0.3	1.1	2.7	3.9	3.8	2.5	1.2	0.6	0.2	0.4	17.1
1981	0.1	0.1	0.3	1.1	2.7	3.9	3.8	2.5	1.2	0.6	0.2	0.4	17.1
1982	0.1	0.1	0.3	1.1	2.7	3.9	3.8	2.5	1.2	0.6	0.2	0.4	17.1
1983	0.1	0.1	0.3	1.1	2.7	3.9	3.8	2.5	1.2	0.6	0.2	0.4	17.1

**Table K-7: Presented as Table I-2: Riparian Diversions Above Woodbridge Diversion Dam\***  
Values shown provide flow in cubic feet per second (cfs) averaged over the monthly period indicated

	Jan	Feb	Mar	Apr	May	Jun	Jul	Aug	Sep	Oct	Nov	Dec	Total
<b>1984</b>	0.1	0.1	0.3	1.1	2.7	3.9	3.8	2.5	1.2	0.6	0.2	0.4	17.1
<b>1985</b>	0.1	0.1	0.3	1.1	2.7	3.9	3.8	2.5	1.2	0.6	0.2	0.4	17.1
<b>1986</b>	0.1	0.1	0.3	1.1	2.7	3.9	3.8	2.5	1.2	0.6	0.2	0.4	17.1
<b>1987</b>	0.1	0.1	0.3	1.1	2.7	3.9	3.8	2.5	1.2	0.6	0.2	0.4	17.1
<b>1988</b>	0.1	0.1	0.3	1.1	2.7	3.9	1.9	1.2	0.6	0.6	0.2	0.4	13.3
<b>1989</b>	0.1	0.1	0.3	1.1	2.7	3.9	3.8	2.5	1.2	0.6	0.2	0.4	17.1
<b>1990</b>	0.1	0.1	0.3	1.1	2.7	3.9	3.8	2.5	1.2	0.6	0.2	0.4	17.1
<b>1991</b>	0.1	0.1	0.3	1.1	2.7	3.9	3.8	2.5	1.2	0.6	0.2	0.4	17.1
<b>1992</b>	0.1	0.1	0.3	1.1	2.7	3.9	3.8	2.5	1.2	0.6	0.2	0.4	17.1
<b>1993</b>	0.1	0.1	0.3	1.1	2.7	3.9	3.8	2.5	1.2	0.6	0.2	0.4	17.1
<b>1994</b>	0.1	0.1	0.3	1.1	2.7	3.9	3.8	2.5	1.2	0.6	0.2	0.4	17.1
<b>1995</b>	0.1	0.1	0.3	1.1	2.7	3.9	3.8	2.5	1.2	0.6	0.2	0.4	17.1
<b>1996</b>	0.1	0.1	0.3	1.1	2.7	3.9	3.8	2.5	1.2	0.6	0.2	0.4	17.1
<b>1997</b>	0.1	0.1	0.3	1.1	2.7	3.9	3.8	2.5	1.2	0.6	0.2	0.4	17.1
<b>1998</b>	0.1	0.1	0.3	1.1	2.7	3.9	3.8	2.5	1.2	0.6	0.2	0.4	17.1
<b>1999</b>	0.1	0.1	0.3	1.1	2.7	3.9	3.8	2.5	1.2	0.6	0.2	0.4	17.1
<b>2000</b>	0.1	0.1	0.3	1.1	2.7	3.9	3.8	2.5	1.2	0.6	0.2	0.4	17.1
<b>2001</b>	0.1	0.1	0.3	1.1	2.7	3.9	3.8	2.5	1.2	0.6	0.2	0.4	17.1
<b>2002</b>	0.1	0.1	0.3	1.1	2.7	3.9	3.8	2.5	1.2	0.6	0.2	0.4	17.1
<b>2003</b>	0.1	0.1	0.3	1.1	2.7	3.9	3.8	2.5	1.2	0.6	0.2	0.4	17.1
<b>2004</b>	0.1	0.1	0.3	1.1	2.7	3.9	3.8	2.5	1.2	0.6	0.2	0.4	17.1
<b>2005</b>	0.1	0.1	0.3	1.1	2.7	3.9	3.8	2.5	1.2	0.6	0.2	0.4	17.1
<b>2006</b>	0.1	0.1	0.3	1.1	2.7	3.9	3.8	2.5	1.2	0.6	0.2	0.4	17.1
<b>2007</b>	0.1	0.1	0.3	1.1	2.7	3.9	3.8	2.5	1.2	0.6	0.2	0.4	17.1
<b>2008</b>	0.1	0.1	0.3	1.1	2.7	3.9	3.8	2.5	1.2	0.6	0.2	0.4	17.1
<b>2009</b>	0.1	0.1	0.3	1.1	2.7	3.9	3.8	2.5	1.2	0.6	0.2	0.4	17.1
<b>2010</b>	0.1	0.1	0.3	1.1	2.7	3.9	3.8	2.5	1.2	0.6	0.2	0.4	17.1
<b>Ave</b>	0.1	0.1	0.3	1.1	2.7	3.9	3.7	2.4	1.2	0.6	0.2	0.4	16.9
<b>Max</b>	0.1	0.1	0.3	1.1	2.7	3.9	3.8	2.5	1.2	0.6	0.2	0.4	17.1
<b>Min</b>	0.1	0.1	0.3	1.1	2.7	3.9	1.9	1.2	0.6	0.6	0.2	0.4	13.3

\*Note: Riparian diversions are the same for both the 2010 and 2040 baseline cases.

**Table K-8: Presented as Table I-3: Riparian Diversions Above Interstate 5 \***  
**Values shown provide flow in cubic feet per second (cfs) averaged over the monthly period indicated**

	<b>Jan</b>	<b>Feb</b>	<b>Mar</b>	<b>Apr</b>	<b>May</b>	<b>Jun</b>	<b>Jul</b>	<b>Aug</b>	<b>Sep</b>	<b>Oct</b>	<b>Nov</b>	<b>Dec</b>	<b>Total</b>
<b>1953</b>	0.7	0.6	2.0	6.5	16.4	23.4	22.9	14.9	7.5	3.5	1.5	2.7	102.7
<b>1954</b>	0.7	0.6	2.0	6.5	16.4	23.4	22.9	14.9	7.5	3.5	1.5	2.7	102.7
<b>1955</b>	0.7	0.6	2.0	6.5	16.4	23.4	22.9	14.9	7.5	3.5	1.5	2.7	102.7
<b>1956</b>	0.7	0.6	2.0	6.5	16.4	23.4	22.9	14.9	7.5	3.5	1.5	2.7	102.7
<b>1957</b>	0.7	0.6	2.0	6.5	16.4	23.4	22.9	14.9	7.5	3.5	1.5	2.7	102.7
<b>1958</b>	0.7	0.6	2.0	6.5	16.4	23.4	22.9	14.9	7.5	3.5	1.5	2.7	102.7
<b>1959</b>	0.7	0.6	2.0	6.5	16.4	23.4	22.9	14.9	7.5	3.5	1.5	2.7	102.7
<b>1960</b>	0.7	0.6	2.0	6.5	16.4	23.4	22.9	14.9	7.5	3.5	1.5	2.7	102.7
<b>1961</b>	0.7	0.6	2.0	6.5	16.4	23.4	22.9	14.9	7.5	3.5	1.5	2.7	102.7
<b>1962</b>	0.7	0.6	2.0	6.5	16.4	23.4	22.9	14.9	7.5	3.5	1.5	2.7	102.7
<b>1963</b>	0.7	0.6	2.0	6.5	16.4	23.4	22.9	14.9	7.5	3.5	1.5	2.7	102.7
<b>1964</b>	0.7	0.6	2.0	6.5	16.4	23.4	22.9	14.9	7.5	3.5	1.5	2.7	102.7
<b>1965</b>	0.7	0.6	2.0	6.5	16.4	23.4	22.9	14.9	7.5	3.5	1.5	2.7	102.7
<b>1966</b>	0.7	0.6	2.0	6.5	16.4	23.4	22.9	14.9	7.5	3.5	1.5	2.7	102.7
<b>1967</b>	0.7	0.6	2.0	6.5	16.4	23.4	22.9	14.9	7.5	3.5	1.5	2.7	102.7
<b>1968</b>	0.7	0.6	2.0	6.5	16.4	23.4	22.9	14.9	7.5	3.5	1.5	2.7	102.7
<b>1969</b>	0.7	0.6	2.0	6.5	16.4	23.4	22.9	14.9	7.5	3.5	1.5	2.7	102.7
<b>1970</b>	0.7	0.6	2.0	6.5	16.4	23.4	22.9	14.9	7.5	3.5	1.5	2.7	102.7
<b>1971</b>	0.7	0.6	2.0	6.5	16.4	23.4	22.9	14.9	7.5	3.5	1.5	2.7	102.7
<b>1972</b>	0.7	0.6	2.0	6.5	16.4	23.4	22.9	14.9	7.5	3.5	1.5	2.7	102.7
<b>1973</b>	0.7	0.6	2.0	6.5	16.4	23.4	22.9	14.9	7.5	3.5	1.5	2.7	102.7
<b>1974</b>	0.7	0.6	2.0	6.5	16.4	23.4	22.9	14.9	7.5	3.5	1.5	2.7	102.7
<b>1975</b>	0.7	0.6	2.0	6.5	16.4	23.4	22.9	14.9	7.5	3.5	1.5	2.7	102.7
<b>1976</b>	0.7	0.6	2.0	6.5	16.5	23.4	11.5	7.5	3.7	3.5	1.5	2.7	80.0
<b>1977</b>	0.7	0.6	2.0	6.5	16.5	23.4	11.5	7.5	3.7	3.5	1.5	2.7	80.0
<b>1978</b>	0.7	0.6	2.0	6.5	16.4	23.4	22.9	14.9	7.5	3.5	1.5	2.7	102.7
<b>1979</b>	0.7	0.6	2.0	6.5	16.4	23.4	22.9	14.9	7.5	3.5	1.5	2.7	102.7
<b>1980</b>	0.7	0.6	2.0	6.5	16.4	23.4	22.9	14.9	7.5	3.5	1.5	2.7	102.7
<b>1981</b>	0.7	0.6	2.0	6.5	16.4	23.4	22.9	14.9	7.5	3.5	1.5	2.7	102.7
<b>1982</b>	0.7	0.6	2.0	6.5	16.4	23.4	22.9	14.9	7.5	3.5	1.5	2.7	102.7
<b>1983</b>	0.7	0.6	2.0	6.5	16.4	23.4	22.9	14.9	7.5	3.5	1.5	2.7	102.7
<b>1984</b>	0.7	0.6	2.0	6.5	16.4	23.4	22.9	14.9	7.5	3.5	1.5	2.7	102.7

**Table K-8: Presented as Table I-3: Riparian Diversions Above Interstate 5 \***  
**Values shown provide flow in cubic feet per second (cfs) averaged over the monthly period indicated**

	<b>Jan</b>	<b>Feb</b>	<b>Mar</b>	<b>Apr</b>	<b>May</b>	<b>Jun</b>	<b>Jul</b>	<b>Aug</b>	<b>Sep</b>	<b>Oct</b>	<b>Nov</b>	<b>Dec</b>	<b>Total</b>
<b>1985</b>	0.7	0.6	2.0	6.5	16.4	23.4	22.9	14.9	7.5	3.5	1.5	2.7	102.7
<b>1986</b>	0.7	0.6	2.0	6.5	16.4	23.4	22.9	14.9	7.5	3.5	1.5	2.7	102.7
<b>1987</b>	0.7	0.6	2.0	6.5	16.4	23.4	22.9	14.9	7.5	3.5	1.5	2.7	102.7
<b>1988</b>	0.7	0.6	2.0	6.5	16.5	23.4	11.5	7.5	3.7	3.5	1.5	2.7	80.0
<b>1989</b>	0.7	0.6	2.0	6.5	16.4	23.4	22.9	14.9	7.5	3.5	1.5	2.7	102.7
<b>1990</b>	0.7	0.6	2.0	6.5	16.4	23.4	22.9	14.9	7.5	3.5	1.5	2.7	102.7
<b>1991</b>	0.7	0.6	2.0	6.5	16.4	23.4	22.9	14.9	7.5	3.5	1.5	2.7	102.7
<b>1992</b>	0.7	0.6	2.0	6.5	16.4	23.4	22.9	14.9	7.5	3.5	1.5	2.7	102.7
<b>1993</b>	0.7	0.6	2.0	6.5	16.4	23.4	22.9	14.9	7.5	3.5	1.5	2.7	102.7
<b>1994</b>	0.7	0.6	2.0	6.5	16.4	23.4	22.9	14.9	7.5	3.5	1.5	2.7	102.7
<b>1995</b>	0.7	0.6	2.0	6.5	16.4	23.4	22.9	14.9	7.5	3.5	1.5	2.7	102.7
<b>1996</b>	0.7	0.6	2.0	6.5	16.4	23.4	22.9	14.9	7.5	3.5	1.5	2.7	102.7
<b>1997</b>	0.7	0.6	2.0	6.5	16.4	23.4	22.9	14.9	7.5	3.5	1.5	2.7	102.7
<b>1998</b>	0.7	0.6	2.0	6.5	16.4	23.4	22.9	14.9	7.5	3.5	1.5	2.7	102.7
<b>1999</b>	0.7	0.6	2.0	6.5	16.4	23.4	22.9	14.9	7.5	3.5	1.5	2.7	102.7
<b>2000</b>	0.7	0.6	2.0	6.5	16.4	23.4	22.9	14.9	7.5	3.5	1.5	2.7	102.7
<b>2001</b>	0.7	0.6	2.0	6.5	16.4	23.4	22.9	14.9	7.5	3.5	1.5	2.7	102.7
<b>2002</b>	0.7	0.6	2.0	6.5	16.4	23.4	22.9	14.9	7.5	3.5	1.5	2.7	102.7
<b>2003</b>	0.7	0.6	2.0	6.5	16.4	23.4	22.9	14.9	7.5	3.5	1.5	2.7	102.7
<b>2004</b>	0.7	0.6	2.0	6.5	16.4	23.4	22.9	14.9	7.5	3.5	1.5	2.7	102.7
<b>2005</b>	0.7	0.6	2.0	6.5	16.4	23.4	22.9	14.9	7.5	3.5	1.5	2.7	102.7
<b>2006</b>	0.7	0.6	2.0	6.5	16.4	23.4	22.9	14.9	7.5	3.5	1.5	2.7	102.7
<b>2007</b>	0.7	0.6	2.0	6.5	16.4	23.4	22.9	14.9	7.5	3.5	1.5	2.7	102.7
<b>2008</b>	0.7	0.6	2.0	6.5	16.4	23.4	22.9	14.9	7.5	3.5	1.5	2.7	102.7
<b>2009</b>	0.7	0.6	2.0	6.5	16.4	23.4	22.9	14.9	7.5	3.5	1.5	2.7	102.7
<b>2010</b>	0.7	0.6	2.0	6.5	16.4	23.4	22.9	14.9	7.5	3.5	1.5	2.7	102.7
<b>Ave</b>	0.7	0.6	2.0	6.5	16.4	23.4	22.3	14.6	7.3	3.5	1.5	2.7	101.5
<b>Max</b>	0.7	0.6	2.0	6.5	16.5	23.4	22.9	14.9	7.5	3.5	1.5	2.7	102.7
<b>Min</b>	0.7	0.6	2.0	6.5	16.4	23.4	11.5	7.5	3.7	3.5	1.5	2.7	80.0

\*Note: Riparian diversions are the same for both the 2010 and 2040 baseline cases.

**Table K-9: Presented as Table J-1: 2010 Unallocated Water below Camanche Dam**  
Values shown provide flow in cubic feet per second (cfs) averaged over the monthly period indicated

	Jan	Feb	Mar	Apr	May	Jun	Jul	Aug	Sep	Oct	Nov	Dec	Total
1953	410.0	0.0	0.0	0.0	386.2	373.8	386.2	386.2	373.8	0.0	0.0	0.0	2,316.3
1954	0.0	0.0	0.0	0.0	8.0	7.8	8.0	8.0	7.8	0.0	0.0	0.0	39.7
1955	0.0	0.0	0.0	0.0	0.0	0.0	0.0	0.0	0.0	0.0	0.0	2,008.1	2,008.1
1956	2,772.2	889.8	118.0	26.7	1,883.8	1,102.4	712.3	712.3	689.4	0.0	0.0	0.0	8,907.0
1957	0.0	0.0	0.0	0.0	186.0	180.0	186.0	186.0	180.0	0.0	0.0	0.0	917.8
1958	0.0	794.3	796.7	1,579.5	2,216.6	1,184.9	801.2	801.2	775.3	0.0	0.0	0.0	8,949.7
1959	0.0	0.0	0.0	0.0	0.0	0.0	0.0	0.0	0.0	0.0	0.0	0.0	0.0
1960	0.0	0.0	0.0	0.0	0.0	0.0	0.0	0.0	0.0	0.0	0.0	0.0	0.0
1961	0.0	0.0	0.0	0.0	0.0	0.0	0.0	0.0	0.0	0.0	0.0	0.0	0.0
1962	0.0	0.0	0.0	0.0	0.0	0.0	0.0	0.0	0.0	0.0	0.0	0.0	0.0
1963	0.0	1,034.1	0.0	0.0	1,283.0	837.2	629.0	629.0	608.7	0.0	381.9	0.0	5,403.0
1964	0.0	0.0	0.0	0.0	0.0	0.0	0.0	0.0	0.0	0.0	0.0	3,807.8	3,807.8
1965	2,129.0	582.9	0.0	202.3	841.9	814.7	841.9	841.9	814.7	0.0	318.4	46.3	7,434.1
1966	44.4	0.0	0.0	0.0	0.0	0.0	0.0	0.0	0.0	0.0	0.0	0.0	44.4
1967	427.3	271.0	809.5	912.8	2,740.9	995.4	1,028.5	1,028.5	995.4	0.0	0.0	0.0	9,209.4
1968	0.0	0.0	0.0	0.0	0.0	0.0	0.0	0.0	0.0	0.0	0.0	0.0	0.0
1969	2,475.3	1,298.7	660.3	2,051.7	2,935.3	1,125.1	862.1	862.1	834.3	0.0	0.0	164.6	13,269.4
1970	3,249.9	709.0	272.4	0.0	255.5	247.3	255.5	255.5	247.3	0.0	359.8	543.5	6,395.5
1971	446.0	289.9	294.8	0.0	438.9	424.7	438.9	438.9	424.7	0.0	81.3	121.8	3,399.8
1972	0.0	0.0	0.0	0.0	0.0	0.0	0.0	0.0	0.0	0.0	0.0	0.0	0.0
1973	756.6	946.5	457.0	0.0	479.4	463.9	479.4	479.4	463.9	0.0	1,069.6	650.2	6,245.8
1974	1,133.4	0.0	640.1	426.9	838.4	712.0	735.7	735.7	712.0	0.0	0.0	0.0	5,934.2
1975	0.0	0.0	0.0	0.0	841.3	814.2	841.3	841.3	814.2	0.0	77.1	0.0	4,229.5
1976	0.0	0.0	0.0	0.0	0.0	0.0	0.0	0.0	0.0	0.0	0.0	0.0	0.0
1977	0.0	0.0	0.0	0.0	0.0	0.0	0.0	0.0	0.0	0.0	0.0	0.0	0.0
1978	0.0	0.0	0.0	0.0	336.4	325.6	336.4	336.4	325.6	0.0	0.0	0.0	1,660.4
1979	0.0	93.8	379.2	1.6	425.3	411.6	425.3	425.3	411.6	0.0	0.0	0.0	2,573.9
1980	2,957.2	2,062.7	292.0	0.0	919.8	788.4	814.7	814.7	788.4	0.0	0.0	0.0	9,438.0
1981	0.0	0.0	0.0	0.0	0.0	0.0	0.0	0.0	0.0	0.0	0.0	1,447.0	1,447.0
1982	1,312.9	2,572.2	1,649.8	3,296.5	2,540.3	1,006.8	1,040.3	1,040.3	1,006.8	0.0	1,102.7	1,506.3	18,074.9

**Table K-9: Presented as Table J-1: 2010 Unallocated Water below Camanche Dam**  
**Values shown provide flow in cubic feet per second (cfs) averaged over the monthly period indicated**

	Jan	Feb	Mar	Apr	May	Jun	Jul	Aug	Sep	Oct	Nov	Dec	Total
1983	1,172.5	1,888.2	3,300.6	1,549.2	3,946.7	2,819.1	1,671.0	1,671.0	1,617.1	0.0	2,030.8	2,512.1	24,178.5
1984	1,283.5	621.3	136.9	0.0	502.7	486.5	502.7	502.7	486.5	0.0	275.6	13.5	4,811.8
1985	0.0	0.0	0.0	0.0	0.0	0.0	0.0	0.0	0.0	0.0	0.0	0.0	0.0
1986	0.0	4,736.8	2,612.1	132.4	1,335.8	570.3	589.3	589.3	570.3	0.0	0.0	0.0	11,136.4
1987	0.0	0.0	0.0	0.0	0.0	0.0	0.0	0.0	0.0	0.0	0.0	0.0	0.0
1988	0.0	0.0	0.0	0.0	0.0	0.0	0.0	0.0	0.0	0.0	0.0	0.0	0.0
1989	0.0	0.0	0.0	0.0	0.0	0.0	0.0	0.0	0.0	0.0	0.0	0.0	0.0
1990	0.0	0.0	0.0	0.0	0.0	0.0	0.0	0.0	0.0	0.0	0.0	0.0	0.0
1991	0.0	0.0	0.0	0.0	0.0	0.0	0.0	0.0	0.0	0.0	0.0	0.0	0.0
1992	0.0	0.0	0.0	0.0	0.0	0.0	0.0	0.0	0.0	0.0	0.0	0.0	0.0
1993	0.0	0.0	0.0	0.0	594.6	575.4	594.6	594.6	575.4	0.0	0.0	0.0	2,934.6
1994	0.0	0.0	0.0	0.0	0.0	0.0	0.0	0.0	0.0	0.0	0.0	0.0	0.0
1995	0.0	551.0	2,772.7	2,291.2	4,018.2	1,485.2	1,300.4	1,300.4	1,258.5	0.0	0.0	0.0	14,977.7
1996	0.0	1,844.7	877.5	152.7	1,527.8	461.7	477.1	477.1	461.7	0.0	300.4	2,146.7	8,727.3
1997	5,962.7	1,243.7	212.2	0.0	211.6	204.8	211.6	211.6	204.8	0.0	170.0	0.0	8,633.0
1998	390.1	1,760.9	1,118.0	1,462.2	2,317.9	1,242.1	1,124.4	1,124.4	1,088.2	0.0	13.3	0.0	11,641.6
1999	346.5	1,501.1	481.7	0.0	686.1	767.2	651.4	651.4	630.3	0.0	0.0	0.0	5,715.7
2000	0.0	802.9	446.4	0.0	305.8	295.9	305.8	305.8	295.9	0.0	0.0	0.0	2,758.5
2001	0.0	0.0	0.0	0.0	0.0	0.0	0.0	0.0	0.0	0.0	0.0	0.0	0.0
2002	0.0	0.0	0.0	0.0	0.0	0.0	0.0	0.0	0.0	0.0	0.0	0.0	0.0
2003	0.0	1.5	0.0	0.0	277.4	268.4	277.4	277.4	268.4	0.0	0.0	0.0	1,370.5
2004	0.0	53.0	215.0	0.0	0.0	0.0	0.0	0.0	0.0	0.0	0.0	0.0	268.0
2005	0.0	529.7	1,121.7	490.6	1,581.5	900.9	664.2	664.2	642.8	0.0	0.0	1,521.0	8,116.7
2006	1,494.3	826.1	1,091.3	3,830.7	2,435.1	1,093.4	542.6	542.6	525.1	0.0	44.4	56.7	12,482.3
2007	0.0	0.0	0.0	0.0	0.0	0.0	0.0	0.0	0.0	0.0	0.0	0.0	0.0
2008	0.0	0.0	0.0	0.0	0.0	0.0	0.0	0.0	0.0	0.0	0.0	0.0	0.0
2009	0.0	0.0	0.0	0.0	83.1	80.4	83.1	83.1	80.4	0.0	0.0	0.0	410.0
2010	0.0	0.0	0.0	0.0	524.3	507.4	524.3	524.3	507.4	0.0	416.8	1,234.4	4,238.8
<b>Ave</b>	495.9	481.1	357.9	317.4	688.0	406.5	350.7	350.7	339.4	0.0	114.5	306.6	4,208.7
<b>Max</b>	5,962.7	4,736.8	3,300.6	3,830.7	4,018.2	2,819.1	1,671.0	1,671.0	1,617.1	0.0	2,030.8	3,807.8	24,178.5
<b>Min</b>	0.0	0.0	0.0	0.0	0.0	0.0	0.0	0.0	0.0	0.0	0.0	0.0	0.0

**Table K-10: Presented as Table J-2: 2040 Unallocated Water below Camanche Dam**  
**Values shown provide flow in cubic feet per second (cfs) averaged over the monthly period indicated**

	Jan	Feb	Mar	Apr	May	Jun	Jul	Aug	Sep	Oct	Nov	Dec	Total
1953	386.8	0.0	0.0	0.0	274.7	265.8	274.7	274.7	265.8	0.0	0.0	0.0	1,742.3
1954	0.0	0.0	0.0	0.0	0.0	0.0	0.0	0.0	0.0	0.0	0.0	0.0	0.0
1955	0.0	0.0	0.0	0.0	0.0	0.0	0.0	0.0	0.0	0.0	0.0	1,794.7	1,794.7
1956	2,749.0	868.2	93.3	3.0	1,805.6	1,003.8	615.8	615.8	596.0	0.0	0.0	0.0	8,350.4
1957	0.0	0.0	0.0	0.0	66.3	64.1	66.3	66.3	64.1	0.0	0.0	0.0	327.2
1958	0.0	700.4	772.0	1,556.3	2,139.0	1,086.9	705.3	705.3	682.5	0.0	0.0	0.0	8,347.7
1959	0.0	0.0	0.0	0.0	0.0	0.0	0.0	0.0	0.0	0.0	0.0	0.0	0.0
1960	0.0	0.0	0.0	0.0	0.0	0.0	0.0	0.0	0.0	0.0	0.0	0.0	0.0
1961	0.0	0.0	0.0	0.0	0.0	0.0	0.0	0.0	0.0	0.0	0.0	0.0	0.0
1962	0.0	0.0	0.0	0.0	0.0	0.0	0.0	0.0	0.0	0.0	0.0	0.0	0.0
1963	0.0	1,758.6	0.0	0.0	1,062.9	729.4	523.8	523.8	506.9	0.0	356.9	0.0	5,462.2
1964	0.0	0.0	0.0	0.0	0.0	0.0	0.0	0.0	0.0	0.0	0.0	3,209.5	3,209.5
1965	2,105.8	561.8	0.0	150.9	754.3	723.0	747.1	747.1	723.0	0.0	293.3	22.1	6,828.3
1966	21.2	0.0	0.0	0.0	0.0	0.0	0.0	0.0	0.0	0.0	0.0	0.0	21.2
1967	73.6	249.9	784.8	892.2	2,666.1	903.9	934.1	934.1	903.9	0.0	0.0	0.0	8,342.7
1968	0.0	0.0	0.0	0.0	0.0	0.0	0.0	0.0	0.0	0.0	0.0	0.0	0.0
1969	2,361.9	1,277.6	639.8	2,029.2	2,858.6	1,028.0	767.0	767.0	742.3	0.0	0.0	115.3	12,586.6
1970	3,226.6	687.8	247.7	0.0	156.8	151.7	156.8	156.8	151.7	0.0	334.7	519.3	5,790.1
1971	422.7	268.8	270.1	0.0	336.4	325.5	336.4	336.4	325.5	0.0	56.2	97.7	2,775.8
1972	0.0	0.0	0.0	0.0	0.0	0.0	0.0	0.0	0.0	0.0	0.0	0.0	0.0
1973	379.1	925.4	432.3	0.0	385.7	373.2	385.7	385.7	373.2	0.0	1,044.6	626.0	5,311.0
1974	1,110.2	0.0	594.3	400.1	760.2	617.3	637.9	637.9	617.3	0.0	0.0	0.0	5,375.2
1975	0.0	0.0	0.0	0.0	715.1	692.0	715.1	715.1	692.0	0.0	52.0	0.0	3,581.4
1976	0.0	0.0	0.0	0.0	0.0	0.0	0.0	0.0	0.0	0.0	0.0	0.0	0.0
1977	0.0	0.0	0.0	0.0	0.0	0.0	0.0	0.0	0.0	0.0	0.0	0.0	0.0
1978	0.0	0.0	0.0	0.0	98.1	94.9	98.1	98.1	94.9	0.0	0.0	0.0	484.2
1979	0.0	0.0	354.4	0.0	323.2	312.7	323.2	323.2	312.7	0.0	0.0	0.0	1,949.3
1980	2,884.6	2,041.0	267.3	0.0	818.9	694.3	717.4	717.4	694.3	0.0	0.0	0.0	8,835.2
1981	0.0	0.0	0.0	0.0	0.0	0.0	0.0	0.0	0.0	0.0	0.0	1,200.1	1,200.1
1982	1,289.7	2,551.1	1,625.1	3,269.7	2,458.8	909.0	939.3	939.3	909.0	0.0	1,077.7	1,482.2	17,450.7
1983	1,149.3	1,867.1	3,276.0	1,522.5	3,865.3	2,717.2	1,571.3	1,571.3	1,520.6	0.0	2,005.8	2,487.9	23,554.0
1984	1,260.2	599.6	112.3	0.0	400.2	387.3	400.2	400.2	387.3	0.0	250.5	0.0	4,197.9



**Table K-10: Presented as Table J-2: 2040 Unallocated Water below Camanche Dam**  
**Values shown provide flow in cubic feet per second (cfs) averaged over the monthly period indicated**

	Jan	Feb	Mar	Apr	May	Jun	Jul	Aug	Sep	Oct	Nov	Dec	Total
1985	0.0	0.0	0.0	0.0	0.0	0.0	0.0	0.0	0.0	0.0	0.0	0.0	0.0
1986	0.0	4,328.1	2,587.4	112.5	1,261.8	479.7	495.7	495.7	479.7	0.0	0.0	0.0	10,240.8
1987	0.0	0.0	0.0	0.0	0.0	0.0	0.0	0.0	0.0	0.0	0.0	0.0	0.0
1988	0.0	0.0	0.0	0.0	0.0	0.0	0.0	0.0	0.0	0.0	0.0	0.0	0.0
1989	0.0	0.0	0.0	0.0	0.0	0.0	0.0	0.0	0.0	0.0	0.0	0.0	0.0
1990	0.0	0.0	0.0	0.0	0.0	0.0	0.0	0.0	0.0	0.0	0.0	0.0	0.0
1991	0.0	0.0	0.0	0.0	0.0	0.0	0.0	0.0	0.0	0.0	0.0	0.0	0.0
1992	0.0	0.0	0.0	0.0	0.0	0.0	0.0	0.0	0.0	0.0	0.0	0.0	0.0
1993	0.0	0.0	0.0	0.0	411.2	397.9	411.2	411.2	397.9	0.0	0.0	0.0	2,029.5
1994	0.0	0.0	0.0	0.0	0.0	0.0	0.0	0.0	0.0	0.0	0.0	0.0	0.0
1995	0.0	310.5	2,749.9	2,266.4	3,938.9	1,385.4	1,202.7	1,202.7	1,163.9	0.0	0.0	0.0	14,220.4
1996	0.0	1,750.2	852.8	130.0	1,450.7	368.1	380.3	380.3	368.1	0.0	275.4	2,122.5	8,078.3
1997	5,939.4	1,222.6	187.6	0.0	113.3	109.6	113.3	113.3	109.6	0.0	144.9	0.0	8,053.7
1998	342.6	1,739.7	1,093.3	1,438.9	2,240.2	1,143.9	1,028.3	1,028.3	995.1	0.0	0.0	0.0	11,050.1
1999	287.3	1,480.0	457.0	0.0	587.9	666.1	555.2	555.2	537.3	0.0	0.0	0.0	5,126.0
2000	0.0	708.2	421.8	0.0	203.3	196.7	203.3	203.3	196.7	0.0	0.0	0.0	2,133.4
2001	0.0	0.0	0.0	0.0	0.0	0.0	0.0	0.0	0.0	0.0	0.0	0.0	0.0
2002	0.0	0.0	0.0	0.0	0.0	0.0	0.0	0.0	0.0	0.0	0.0	0.0	0.0
2003	0.0	0.0	0.0	0.0	47.8	46.3	47.8	47.8	46.3	0.0	0.0	0.0	236.1
2004	0.0	0.0	148.8	0.0	0.0	0.0	0.0	0.0	0.0	0.0	0.0	0.0	148.8
2005	0.0	197.1	1,097.0	463.9	1,507.2	806.1	571.5	571.5	553.1	0.0	0.0	1,471.7	7,239.2
2006	1,471.0	804.9	1,066.7	3,807.5	2,357.5	995.3	446.6	446.6	432.2	0.0	19.4	32.5	11,880.1
2007	0.0	0.0	0.0	0.0	0.0	0.0	0.0	0.0	0.0	0.0	0.0	0.0	0.0
2008	0.0	0.0	0.0	0.0	0.0	0.0	0.0	0.0	0.0	0.0	0.0	0.0	0.0
2009	0.0	0.0	0.0	0.0	0.0	0.0	0.0	0.0	0.0	0.0	0.0	0.0	0.0
2010	0.0	0.0	0.0	0.0	377.3	365.1	377.3	377.3	365.1	0.0	391.8	1,210.3	3,464.0
<b>Ave</b>	473.5	463.8	347.1	311.1	628.3	345.5	288.8	288.8	279.5	0.0	108.7	282.6	3,817.6
<b>Max</b>	5,939.4	4,328.1	3,276.0	3,807.5	3,938.9	2,717.2	1,571.3	1,571.3	1,520.6	0.0	2,005.8	3,209.5	23,554.0
<b>Min</b>	0.0	0.0	0.0	0.0	0.0	0.0	0.0	0.0	0.0	0.0	0.0	0.0	0.0